

# QVE00039

## PHOTOTRANSISTOR OPTICAL INTERRUPTER SWITCH

### PACKAGE DIMENSIONS

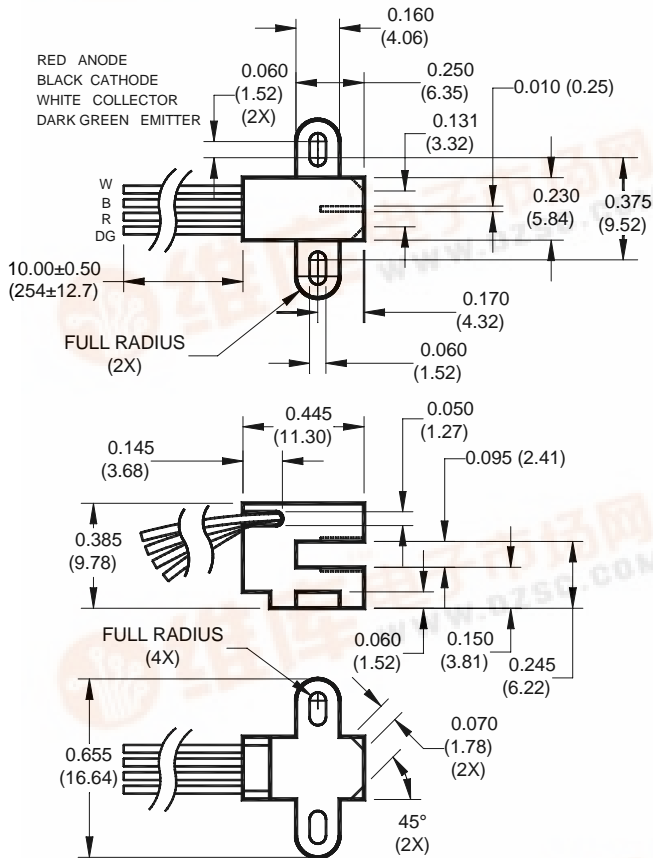

**NOTES:**

1. Dimensions are in inches (mm)
2. Tolerance of  $\pm .010 (.25)$  on all non nominal dimensions unless otherwise specified.
3. Wire gauge: 28 AWG

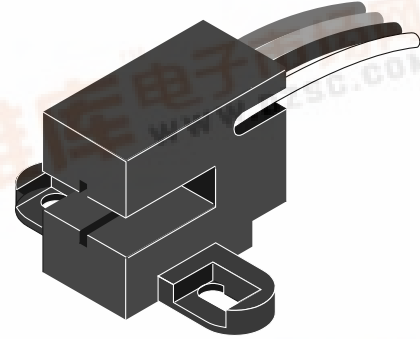

### SCHEMATIC

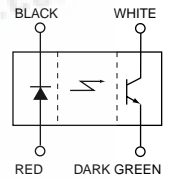

### FEATURES

- No contact switching
- 2.41 mm wide slot
- Slot horizontal to mounting surface
- Mounting tabs
- Transistor Output
- Wire leads for remote connection 10" (254mm)
- Opaque black plastic housing
- 0.010 (0.25) aperture width

### NOTES (Applies to Max Ratings and Characteristics Tables.)

1. Derate power dissipation linearly 1.67 mW/°C above 25°C.
2. RMA flux is recommended.
3. Methanol or isopropyl alcohols are recommended as cleaning agents.
4. Soldering iron 1/16" (1.6mm) minimum from housing.

### ABSOLUTE MAXIMUM RATINGS (T<sub>A</sub> = 25°C unless otherwise specified)

Parameter	Symbol	Rating	Units
Operating Temperature	T <sub>OPR</sub>	-40 to +85	°C
Storage Temperature	T <sub>STG</sub>	-40 to +85	°C
Lead Soldering Temperature (Iron) <sup>(2,3,4)</sup>	T <sub>SOL-I</sub>	240 for 5 sec	°C
<b>EMITTER</b>			
Continuous Forward Current	I <sub>F</sub>	50	mA
Reverse Voltage	V <sub>R</sub>	5	V
Power Dissipation <sup>(1)</sup>	P <sub>D</sub>	100	mW
<b>SENSOR</b>			
Collector-Emitter Voltage	V <sub>CEO</sub>	30	V
Emitter-Collector Voltage	V <sub>ECO</sub>	4.5	V
Power Dissipation <sup>(1)</sup>	P <sub>D</sub>	100	mW



ELECTRICAL / OPTICAL CHARACTERISTICS ( $T_A = 25^\circ\text{C}$ )						
PARAMETER	TEST CONDITIONS	SYMBOL	MIN	TYP	MAX	UNITS
<b>EMITTER</b>						
Forward Voltage	$I_F = 20\text{ mA}$	$V_F$	—	—	1.7	V
Reverse Current	$V_R = 5\text{ V}$	$I_R$	—	—	100	$\mu\text{A}$
Peak Emission Wavelength	$I_F = 20\text{ mA}$	$\lambda_{PE}$	—	940	—	nm
<b>SENSOR</b>						
Collector-Emitter Breakdown	$I_C = 1\text{ mA}$	$BV_{CEO}$	30	—	—	V
Emitter-Collector Breakdown	$I_E = 0.1\text{ mA}$	$BV_{ECO}$	5	—	—	V
Dark Current	$V_{CE} = 10\text{ V}, I_F = 0\text{ mA}$	$I_D$	—	—	100	nA
<b>COUPLED</b>						
Collector Current	$I_F = 20\text{ mA}, V_{CE} = 10\text{ V}$	$I_{C(ON)}$	0.5	—	—	mA
Collector Emitter Saturation Voltage	$I_F = 20\text{ mA}, I_C = 0.4\text{ mA}$	$V_{CE(SAT)}$	—	—	0.4	V
Rise Time	$V_{CE} = 5\text{ V}, R_L = 100\ \Omega$	$t_r$	—	8	—	$\mu\text{s}$
Fall Time	$I_{C(ON)} = 5\text{ mA}$	$t_f$	—	50	—	$\mu\text{s}$

### TYPICAL PERFORMANCE CURVES

Fig. 1 Forward Voltage vs. Ambient Temperature

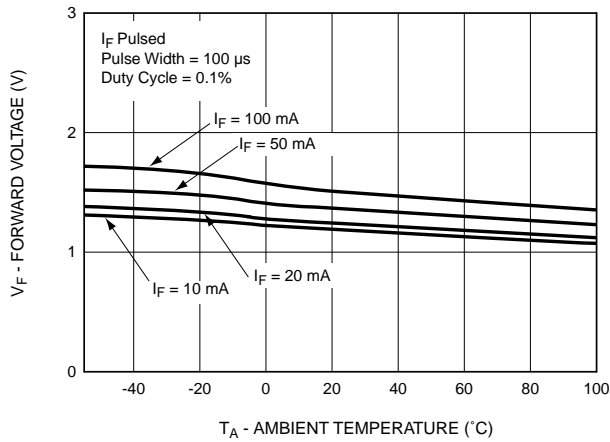

Fig. 2 Forward Current Vs. Forward Voltage

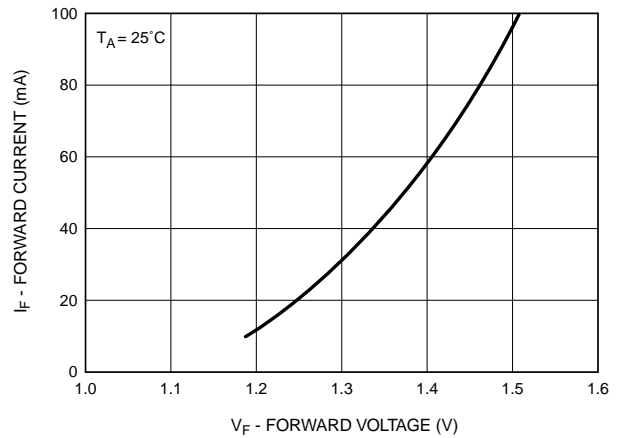

Fig. 3 Collector Emitter Dark Current (Normalized) vs. Ambient Temperature

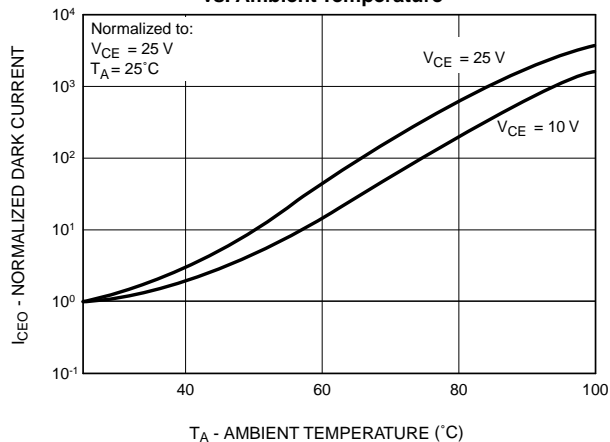
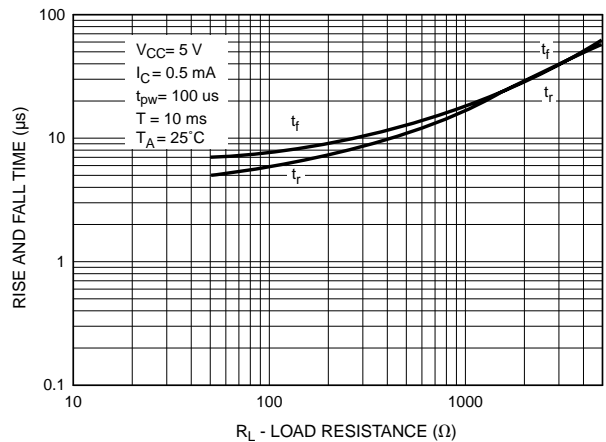
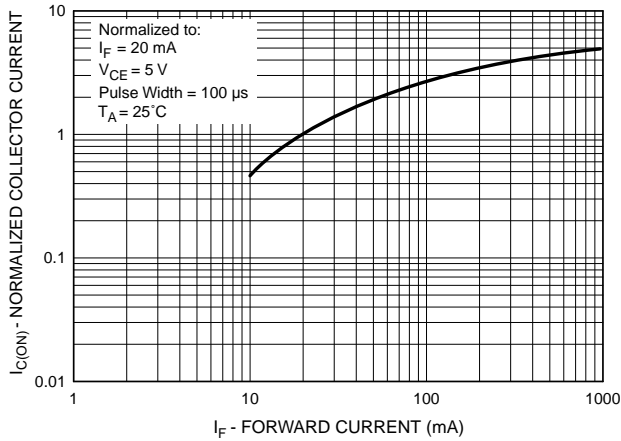

Fig. 4 Rise and Fall Time vs. Load Resistance



**Fig. 5 Normalized Collector Current vs. Forward Current**



**Fig. 6 Collector Current vs. Collector to Emitter Voltage**

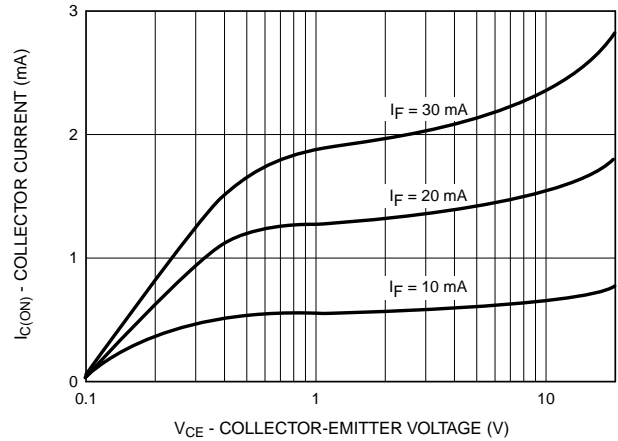

**Fig. 7 Normalized Collector Current vs. Ambient Temperature**

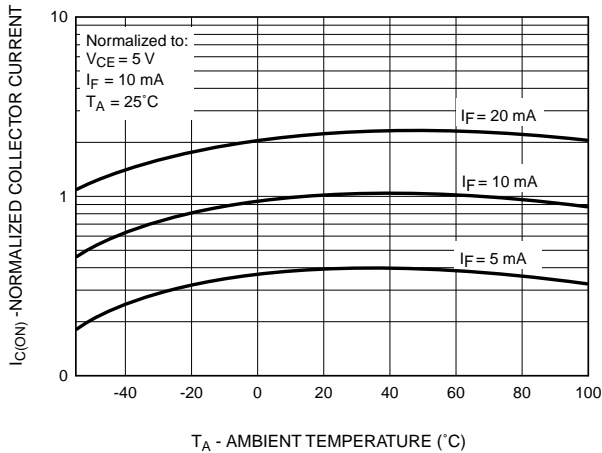

**Fig. 8 Normalized Collector Current vs. Shield Distance**

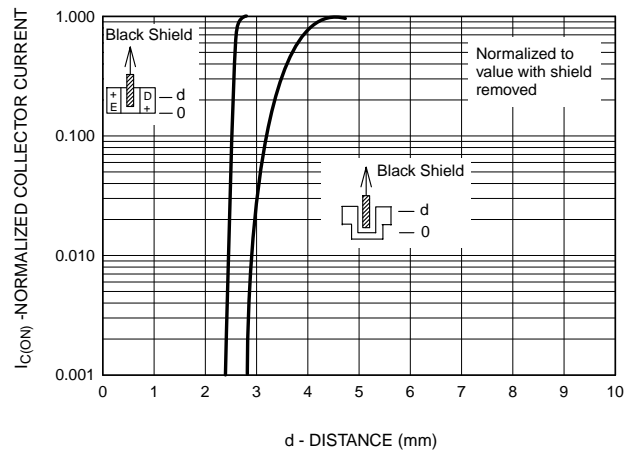

**Fig. 9 Normalized Reverse Leakage Current vs. Ambient Temperature**

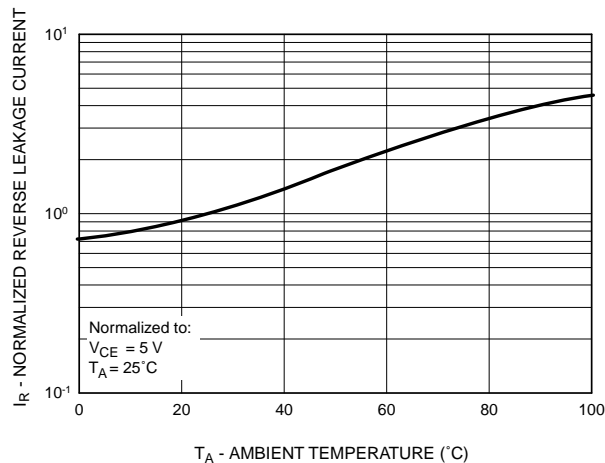

### **DISCLAIMER**

FAIRCHILD SEMICONDUCTOR RESERVES THE RIGHT TO MAKE CHANGES WITHOUT FURTHER NOTICE TO ANY PRODUCTS HEREIN TO IMPROVE RELIABILITY, FUNCTION OR DESIGN. FAIRCHILD DOES NOT ASSUME ANY LIABILITY ARISING OUT OF THE APPLICATION OR USE OF ANY PRODUCT OR CIRCUIT DESCRIBED HEREIN; NEITHER DOES IT CONVEY ANY LICENSE UNDER ITS PATENT RIGHTS, NOR THE RIGHTS OF OTHERS.

### **LIFE SUPPORT POLICY**

FAIRCHILD'S PRODUCTS ARE NOT AUTHORIZED FOR USE AS CRITICAL COMPONENTS IN LIFE SUPPORT DEVICES OR SYSTEMS WITHOUT THE EXPRESS WRITTEN APPROVAL OF THE PRESIDENT OF FAIRCHILD SEMICONDUCTOR CORPORATION. As used herein:

1. Life support devices or systems are devices or systems which, (a) are intended for surgical implant into the body, or (b) support or sustain life, and (c) whose failure to perform when properly used in accordance with instructions for use provided in the labeling, can be reasonably expected to result in a significant injury of the user.
2. A critical component in any component of a life support device or system whose failure to perform can be reasonably expected to cause the failure of the life support device or system, or to affect its safety or effectiveness.