

# QXpander™ processor

## QX2130FS / QX2130S

The QX pander chip (QX-2000 Series) is a sound enhancement sound processor based on QSOUND's QX pander™ technology, and produces virtual 3D sound from ordinary audio signals. This IC requires no special encoding of input signals or additional speakers, and so simplifies the development of high-value-added personal computers, televisions and audio products.

### ●Applications

Speaker systems for desktop and notebook multimedia personal computers, televisions, audio equipment, video games and other devices

### ●Features

- 1) Virtual 3D sound from ordinary audio signals.
- 2) No special encoding signals are necessary.
- 3) Three enhanced modes:
  - QX1: Pro Listening
  - QX2: Wide Listening
  - QX3: Wow for Games
- 4) Internal functions for personal computers: power saver function, output muting function and stereo bypass function.
- 5) TTL-compatible control pins (at 5V).
- 6) Low noise ( $45\mu V_{rms}$ )
- 7) Low power consumption
- 8) Available in SSOP-A20 pin package or SDIP22 pin package.

### ●Block diagram

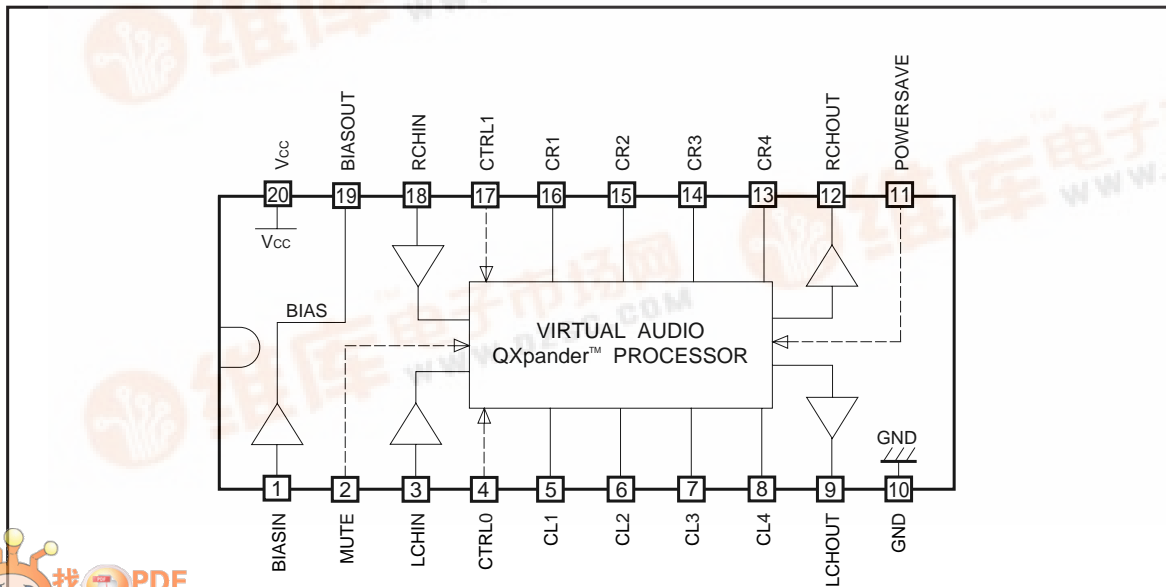

Note: The above diagram is for the QX2130FS (SSOP - A20 package)

● Absolute maximum ratings (Ta = 25°C)

Parameter	Symbol	Limits		Unit
Power supply voltage	V <sub>cc</sub>	13		V
Power dissipation	P <sub>d</sub>	QX2130FS	1000*1	mW
		QX2130S	750*2	
Operating temperature	T <sub>opr</sub>	0 ~ + 70		°C
Storage temperature	T <sub>stg</sub>	- 55 ~ + 125		°C

\*1 When mounted on a 90 × 50 × 1.6mm glass epoxy board  
Reduced by 10.0mW for each increase in Ta of 1°C over 25°C.

\*2 When mounted on a 90 × 50 × 1.6mm glass epoxy board  
Reduced by 7.5mW for each increase in Ta of 1°C over 25°C.

● Recommended operating conditions (Ta = 25°C)

Parameter	Symbol	Min.	Typ.	Max.	Unit
Operating power supply voltage	V <sub>cc</sub>	4.5	—	12.5	V

●Input / output circuits (with QX2130FS)

1pin	BIAS IN	2pin	MUTE	3pin	LCH IN	4pin	CTRL0	5pin	CL1
6pin	CL2	7pin	CL3	8pin	CL4	9pin	LCH OUT	11pin	POWER SAVE
12pin	RCH OUT	13pin	CR4	14pin	CR3	15pin	CR2	16pin	CR1
pin17	CTRL1	18pin	RCH IN	19pin	BIAS OUT				

● Analog characteristics ( $V_{CC} = +5V$  DC,  $GND = 0V$  DC,  $T_a = 25^\circ C$ )

Parameter	Symbol	Min.	Typ.	Max.	Unit	Conditions
(Supply current)						
Supply current (QX mode)	I <sub>CC1</sub>	1.3	3.0	5.2	mA	No signal Input
Supply current (stereo mode)	I <sub>CC2</sub>	1.3	3.0	5.2	mA	No signal Input
Supply current (power saving mode)	I <sub>CC3</sub>	—	230	500	μA	No signal Input
(Maximum input level)						
Maximum input level (QX3 mode)	V <sub>INMax.1</sub>	-8.3	-5.3	—	dBV	V <sub>IN</sub> = 100Hz V <sub>OUT</sub> 1% SINGLE channel INPUT
Maximum input level (QX2 mode)	V <sub>INMax.2</sub>	-7.6	-4.6	—	dBV	V <sub>IN</sub> = 100Hz V <sub>OUT</sub> 1% SINGLE channel INPUT
Maximum input level (QX1 mode)	V <sub>INMax.3</sub>	-7.4	-4.4	—	dBV	V <sub>IN</sub> = 1kHz V <sub>OUT</sub> 1% SINGLE channel INPUT
Maximum input level (stereo mode)	V <sub>INMax.4</sub>	-2.4	+0.6	—	dBV	V <sub>IN</sub> = 1kHz V <sub>OUT</sub> 1% SINGLE channel INPUT
Maximum output level	V <sub>OUTMax.</sub>	-3.0	+0.5	—	dBV	V <sub>IN</sub> = 1kHz V <sub>OUT</sub> 1% SINGLE channel INPUT
(Maximum mute level)						
Maximum mute level (QX mode)	VMUTE1	—	-86	-76	dBV	BW: DIN AUDIO V <sub>IN</sub> = 1kHz, -20dBV
Maximum mute level (stereo mode)	VMUTE2	—	-97	-87	dBV	BW: DIN AUDIO V <sub>IN</sub> = 1kHz, -20dBV
Channel balance	CB	-1.5	0	+1.5	dB	V <sub>IN</sub> = 600Hz, L + RIN
Output current	I <sub>OUT</sub>	—	—	+ / -1	mA	—
Load resistance	R <sub>L</sub>	10	—	—	kΩ	—
Load capacitance	C <sub>L</sub>	—	—	1000	pF	—
Input impedance	R <sub>IN</sub>	50	75	100	kΩ	—
Output impedance	R <sub>OUT</sub>	—	—	200	Ω	—
(Distortion)						
Distortion (QX3 mode)	DSTN1	—	0.15	0.5	%	THD + NOISE V <sub>IN</sub> = 1kHz, -20dBV
Distortion (QX2 mode)	DSTN2	—	0.07	0.3	%	THD + NOISE V <sub>IN</sub> = 1kHz, -20dBV
Distortion (QX1 mode)	DSTN3	—	0.04	0.2	%	THD + NOISE V <sub>IN</sub> = 1kHz, -20dBV
Distortion (stereo mode)	DSTN4	—	0.02	0.2	%	THD + NOISE V <sub>IN</sub> = 1kHz, -20dBV
(Output noise voltage)						
Output noise voltage (QX mode)	VNOISE1	—	-87	-77	dBV	BW: DIN AUDIO R <sub>g</sub> = 600Ω
Output noise voltage (stereo mode)	VNOISE2	—	-98	-88	dBV	BW: DIN AUDIO R <sub>g</sub> = 600Ω
(Crosstalk)						
Crosstalk (stereo mode)	C <sub>T</sub>	—	-98	-88	dBV	BW: DIN AUDIO V <sub>IN</sub> = 1kHz, -20dBV

\* BW1: 400Hz - 30kHz (V<sub>IN</sub> = 1kHz), BW2: -30kHz (V<sub>IN</sub> = 100Hz)

(V<sub>CC</sub> = + 12V DC, GND = 0V DC, T<sub>a</sub> = 25°C)

Parameter	Symbol	Min.	Typ.	Max.	Unit	Conditions
(Supply current)						
Supply current (QX mode)	I <sub>CC1</sub>	2.0	4.9	12.0	mA	Quiescent
Supply current (stereo mode)	I <sub>CC2</sub>	2.0	4.9	12.0	mA	Quiescent
Supply current (power saving mode)	I <sub>CC3</sub>	—	560	1200	μA	Quiescent
(Maximum input level)						
Maximum input level (QX3 mode)	V <sub>INMAX.1</sub>	+ 1.6	+ 4.6	—	dBV	V <sub>IN</sub> = 100Hz V <sub>OUT</sub> 1% SINGLE channel. INPUT
Maximum input level (QX2 mode)	V <sub>INMAX.2</sub>	+ 2.3	+ 5.3	—	dBV	V <sub>IN</sub> = 100Hz V <sub>OUT</sub> 1% SINGLE channel INPUT
Maximum input level (QX1 mode)	V <sub>INMAX.3</sub>	+ 2.5	+ 5.5	—	dBV	V <sub>IN</sub> = 1kHz V <sub>OUT</sub> 1% SINGLE channel INPUT
Maximum input level (stereo mode)	V <sub>INMAX.4</sub>	+ 8.0	+ 11.0	—	dBV	V <sub>IN</sub> = 1kHz V <sub>OUT</sub> 1% SINGLE channel INPUT
Maximum output level	V <sub>OUTMax.</sub>	+ 7.8	+ 10.8	—	dBV	V <sub>IN</sub> = 1kHz V <sub>OUT</sub> 1% SINGLE channel INPUT
(Maximum mute level)						
Maximum mute level (QX mode)	VMUTE1	—	– 85	– 75	dBV	BW: DIN AUDIO V <sub>IN</sub> = 1kHz, – 20dBV
Maximum mute level (stereo mode)	VMUTE2	—	– 97	– 87	dBV	BW: DIN AUDIO V <sub>IN</sub> = 1kHz, – 20dBV
Channel balance	CB	—	0	—	dB	V <sub>IN</sub> = 600kHz, L + R <sub>IN</sub>
Output current	I <sub>OUT</sub>	—	—	± 1	mA	
Load resistance	R <sub>L</sub>	10	—	—	kΩ	
Load capacitance	C <sub>L</sub>	—	—	1000	pF	
Input impedance	R <sub>IN</sub>	50	75	100	kΩ	
Output impedance	R <sub>OUT</sub>	—	—	200	Ω	
(Distortion)						
Distortion (QX3 mode)	DSTN1	—	0.16	0.5	%	THD + NOISE V <sub>IN</sub> = 1kHz, – 20dBV
Distortion (QX2 mode)	DSTN2	—	0.07	0.3	%	THD + NOISE V <sub>IN</sub> = 1kHz, – 20dBV
Distortion (QX1 mode)	DSTN3	—	0.05	0.2	%	THD + NOISE V <sub>IN</sub> = 1kHz, – 20dBV
Distortion (stereo mode)	DSTN4	—	0.02	0.2	%	THD + NOISE V <sub>IN</sub> = 1kHz, – 20dBV
(Output noise voltage)						
Output noise voltage (QX mode)	VNOISE1	—	– 85	– 75	dBV	BW: DIN AUDIO R <sub>g</sub> = 600Ω
Output noise voltage (stereo mode)	VNOISE2	—	– 99	– 89	dBV	BW: DIN AUDIO R <sub>g</sub> = 600Ω
(Crosstalk)						
Crosstalk (stereo mode)	C <sub>T</sub>	—	– 98	– 88	dBV	BW: DIN AUDIO V <sub>IN</sub> = 1kHz, – 20dBV

\* BW1: 400Hz – 30kHz (V<sub>IN</sub> = 1kHz), BW2: – 30kHz (V<sub>IN</sub> = 100Hz)

●Digital characteristics ( $V_{CC} = 4.5 - 5.5V$  DC,  $GND = 0V$  DC,  $T_a = 25^{\circ}C$ )

Parameter	Symbol	Min.	Typ.	Max.	Unit	Conditions
High level Input voltage	$V_{IH}$	2.0	—	5.0	V	
Low level Input voltage	$V_{IL}$	0.0	—	0.8	V	
I / O current, high level	$I_{IH}$	0.0	—	0.3	mA	$V_{IH} = V_{CC}$
I / O current, low level	$I_{IL}$	0.0	—	0.1	mA	$V_{IL} = 0V$

( $V_{CC} = 5.6 - 12.5V$  DC,  $GND = 0V$  DC,  $T_a = 25^{\circ}C$ )

Parameter	Symbol	Min.	Typ.	Max.	Unit	Conditions
High level Input voltage	$V_{IH}$	2.5	—	5.0	V	
Low level Input voltage	$V_{IL}$	0.0	—	0.8	V	
I / O current, high level	$I_{IH}$	0.0	—	0.4	mA	$V_{IH} = 5V$
I / O current, low level	$I_{IL}$	0.0	—	0.1	mA	$V_{IL} = 0V$

●Measurement circuit

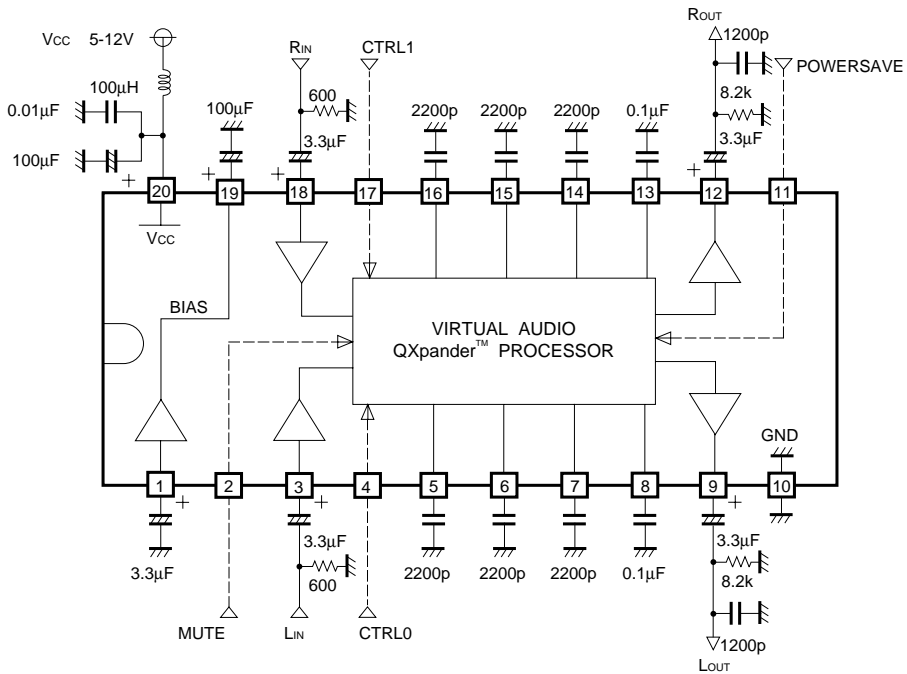

Fig.1

Unit: R (Ω)  
C (F)  
L (H)

Note: This diagram is for the QX2130FS (SSOP - A20 package) .

## ●Control mode

(1) CTRL0 &amp; CTRL1 (pins 4 and 17)

CTRL0	CTRL1	MODE	FUNCTIONS	ENHANCEMENT
L	H	STEREO	Stereo Bypass	—
L	H	QX1	Pro Listening	Minimum
H	L	QX2	Wide Listening	Middle
H	H	QX3	Wow for Games	Maximum

(2) Mute (pin 2)

CTRL	MODE	FUNCTIONS
L	NOT Mute	Enabled Output (Lch / Rch)
H	Mute	Muted Output (Lch / Rch)

(3) Power saving mode (pin 11)

CTRL	MODE	FUNCTIONS
L	Active	Normal
H	Powersave	Shut Down

●Application example

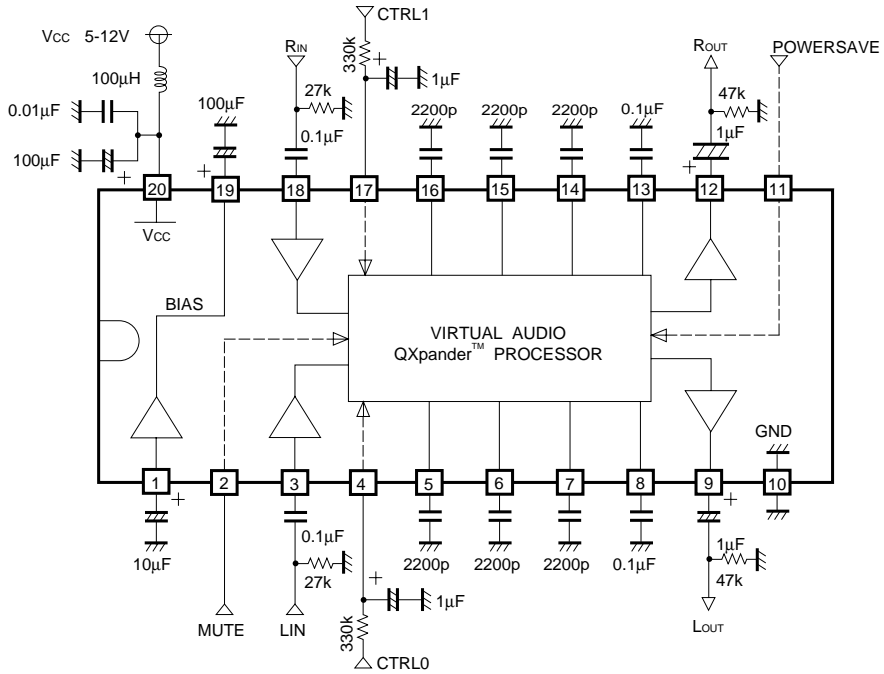

Fig.2

Unit: R ( $\Omega$ )  
 C (F)  
 L (H)

Note: The above diagram is for the QX2130FS (SSOP-A20 package) .



●Operation notes

The QX2130FS and QX2130S were developed using technologies patented by QSOUND (U.S.A.) (patents 5,105,462 and 5,208,860), as well as other patented technologies (including related patents pending both inside and outside Japan). To use this IC, this technology must be licensed from QSOUND.

For inquiries concerning QSOUND™ licensing and technologies, contact:  
 David Gallagher  
 QSOUND LABS, INC.  
 2748 37th Ave. N.E. Calgary, Alberta, Canada  
 T1Y 5L3  
 Phone: 1-403-291-2492 Fax: 1-403-250-1521  
 bbs : 1-403-291-3206

The QSOUND logo and Qx pander™ are registered trademarks of QSOUND. QSOUND recommends that licensed users display the SQOUND logo.

●External dimensions (Units: mm)

