

Powerex, Inc., 200 Hillis Street, Youngwood, Pennsylvania 15697-1800 (412) 925-7272
 Powerex, Europe, S.A. 428 Avenue G. Durand, BP107, 72003 Le Mans, France (43) 41.14.14

General Purpose Rectifier
300-500 Amperes
2400 Volts

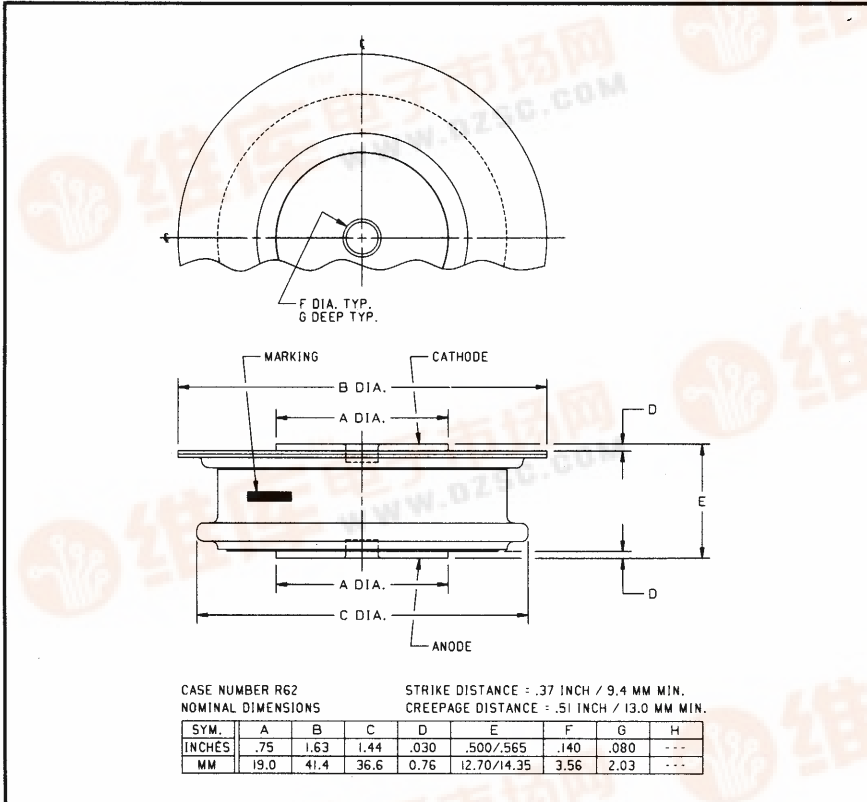

R620 (Outline Drawing)

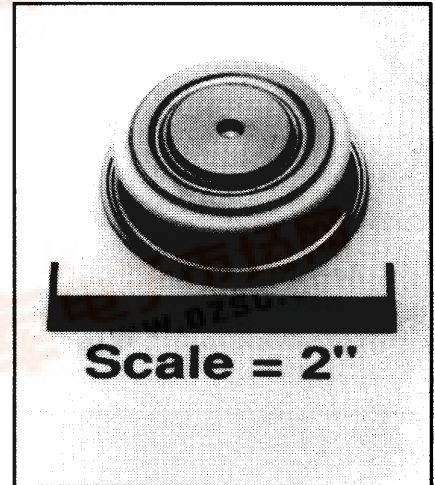

R620
 General Purpose Rectifier
 300-500 Amperes, 2400 Volts

Ordering Information:

Select the complete part number you desire from the following table:

Type	Voltage		Current		Recovery Time		Recovery Time Circuit		Leads	
	V _{RRM} (Volts)	Code	I _{F(av)} (A)	Code	t _{rr} (μsec)	Code	Circuit	Code	Case	Code
R620	200	02	300	30	11	X	JEDEC	X	R62	OO
	400	04	400	40	9	X				
	600	06			6	X				
	800	08								
	1000	10			(Typical)					
	1200	12								
	1400	14								
	1600	16								
	1800	18								
	2000	20								
2200	22									
2400	24									

Example: Type R620 rated at 500A average with V_{RRM} = 2400V

Type	Voltage	Current	Time	Circuit	Leads
R 6 2 0	2 4	5 0	X	X	O O

Features:

- High Surge Current Ratings
- High Rated Blocking Voltages
- Special Electrical Selection for Parallel and Series Operation
- Single or Double-sided Cooling
- Long Creepage and Strike Paths
- Hermetic Seal

Applications:

- Rectification
- Free Wheeling Diode
- Battery Chargers
- Resistance Welding





Powerex, Inc., 200 Hillis Street, Youngwood, Pennsylvania 15697-1800 (412) 925-7272
 Powerex, Europe, S.A. 428 Avenue G. Durand, BP107, 72003 Le Mans, France (43) 41.14.14

R620
General Purpose Rectifier
 300-500 Amperes, 2400 Volts

Absolute Maximum Ratings

Characteristics	Symbol	R620_30	R620_40	R620_50	Units
RMS Forward Current	$I_{F(rms)}$	470	625	785	Amperes
Average Forward Current	$I_{F(av)}$	300	400	500	Amperes
One-half Cycle Surge Current	I_{FSM}	5500	6000	6500	Amperes
3 Cycle Surge Current	I_{FSM}	4300	4700	5050	Amperes
10 Cycle Surge Current	I_{FSM}	3300	3600	3900	Amperes
I^2t (for Fusing), Times = 8.3 milliseconds	I^2t	125000	150000	175000	A^2sec
Max. I^2t of Package (t = 8.3ms)	I^2t	20×10^6	20×10^6	20×10^6	A^2sec
Storage Temperature	T_{stg}	-65 to +190	-65 to +190	-65 to +190	$^{\circ}C$
Operating Temperature	T_j	Up to 1400V -65 to +190	1400V to 2200V -65 to +175	2200V to 2600V -65 to +150	$^{\circ}C$
Mounting Force		1000 to 1400	1000 to 1400	1000 to 1400	lbs

Electrical and Thermal Characteristics

Characteristics	Symbol	Test Conditions	R620_30	R620_40	R620_50	Units
Current - Conducting State Maximums						
Forward Voltage Drop	V_{FM}	$T_j = 25^{\circ}C, I_{FM} = 800A$	1.70	1.50	1.40	Volts
Voltage - Blocking State Maximums						
Repetitive Peak Reverse Voltage (Rated Limit)	V_{RRM}		2400	2400	2400	Volts
Non-rep. Trans. Peak Rev. Voltage (Rated Limit)	V_{RSM}	$t \leq 5.0\mu sec$	2600	2600	2600	Volts
Reverse Leakage Current	I_{RRM}	T_j at max., V_{RRM} Rated	50	50	50	mA
Switching						
Typical Reverse Recovery Time	t_{rr}	$I_{FM} = 785A, t_p = 100\mu sec,$ $di_F/dt = 25A/msec,$ $T_C = 25^{\circ}C$	Up to 1400V 6	1400V to 2200V 9	2200V to 2600V 11	μsec
Thermal						
Maximum Resistance, Double-sided Cooling, Junction to Case	$R_{\theta(j-c)}$		0.095	0.095	0.095	$^{\circ}C/Watt$
Maximum Resistance, Case to Sink (Lubricated)	$R_{\theta(c-s)}$		0.02	0.02	0.02	$^{\circ}C/Watt$

