



# 3 Volt Intel® Advanced+ Boot Block Flash Memory (C3) Stacked-Chip Scale Package Family

## Datasheet

### Product Features

- **Flash Memory Plus SRAM**
  - Reduces Memory Board Space Required, Simplifying PCB Design Complexity
- **Stacked-Chip Scale Package (Stacked-CSP) Technology**
  - Smallest Memory Subsystem Footprint
  - Area : 8 x 10 mm for 16Mbit (0.13 μm) Flash + 2Mbit or 4Mbit SRAM
  - Area : 8 x 12 mm for 32Mbit (0.13 μm) Flash + 4Mbit or 8Mbit SRAM
  - Height : 1.20 mm for 16Mbit (0.13 μm) Flash + 2Mbit or 4Mbit SRAM and 32Mbit (0.13μm) Flash + 8Mbit SRAM
  - Height : 1.40 mm for 32Mbit (0.13 μm) Flash + 4Mbit SRAM
  - This Family also includes 0.25 μm and 0.18 μm technologies
- **Advanced SRAM Technology**
  - 70 ns Access Time
  - Low Power Operation
  - Low Voltage Data Retention Mode
- **Intel® Flash Data Integrator (FDI) Software**
  - Real-Time Data Storage and Code Execution in the Same Memory Device
  - Full Flash File Manager Capability
- **Advanced+ Boot Block Flash Memory**
  - 70 ns Access Time at 2.7 V
  - Instant, Individual Block Locking
  - 128 bit Protection Register
  - 12 V Production Programming
  - Ultra Fast Program and Erase Suspend
  - Extended Temperature -25 °C to +85 °C
- **Blocking Architecture**
  - Block Sizes for Code + Data Storage
  - 4-Kword Parameter Blocks (for data)
  - 64-Kbyte Main Blocks (for code)
  - 100,000 Erase Cycles per Block
- **Low Power Operation**
  - Async Read Current: 9 mA (Flash)
  - Standby Current: 7 μA (Flash)
  - Automatic Power Saving Mode
- **Flash Technologies**
  - 0.25 μm ETOX™ VI, 0.18 μm ETOX™ VII and 0.13 μm ETOX™ VIII Flash Technologies
  - 28F160xC3, 28F320xC3

The 3 Volt Intel® Advanced+ Boot Block Flash Memory (C3) Stacked-Chip Scale Package (Stacked-CSP) device delivers a feature-rich solution for low-power applications. The C3 Stacked-CSP memory device incorporates flash memory and static RAM in one package with low voltage capability to achieve the smallest system memory solution form-factor together with high-speed, low-power operations. The C3 Stacked-CSP memory device offers a protection register and flexible block locking to enable next generation security capability. Combined with the Intel® Flash Data Integrator (Intel® FDI) software, the C3 Stacked-CSP memory device provides a cost-effective, flexible, code plus data storage solution.

**Notice:** This document contains information on new products in production. The specifications are subject to change without notice. Verify with your local Intel sales office that you have the latest datasheet before finalizing a design.





INFORMATION IN THIS DOCUMENT IS PROVIDED IN CONNECTION WITH INTEL® PRODUCTS. NO LICENSE, EXPRESS OR IMPLIED, BY ESTOPPEL OR OTHERWISE, TO ANY INTELLECTUAL PROPERTY RIGHTS IS GRANTED BY THIS DOCUMENT. EXCEPT AS PROVIDED IN INTEL'S TERMS AND CONDITIONS OF SALE FOR SUCH PRODUCTS, INTEL ASSUMES NO LIABILITY WHATSOEVER, AND INTEL DISCLAIMS ANY EXPRESS OR IMPLIED WARRANTY, RELATING TO SALE AND/OR USE OF INTEL PRODUCTS INCLUDING LIABILITY OR WARRANTIES RELATING TO FITNESS FOR A PARTICULAR PURPOSE, MERCHANTABILITY, OR INFRINGEMENT OF ANY PATENT, COPYRIGHT OR OTHER INTELLECTUAL PROPERTY RIGHT. Intel products are not intended for use in medical, life saving, or life sustaining applications.

Intel may make changes to specifications and product descriptions at any time, without notice.

The 3 Volt Intel® Advanced+ Boot Block Flash Memory Stacked-CSP Family may contain design defects or errors known as errata which may cause the product to deviate from published specifications. Current characterized errata are available on request.

MPEG is an international standard for video compression/decompression promoted by ISO. Implementations of MPEG CODECs, or MPEG enabled platforms may require licenses from various entities, including Intel Corporation.

Contact your local Intel sales office or your distributor to obtain the latest specifications and before placing your product order.

Copies of documents which have an ordering number and are referenced in this document, or other Intel literature may be obtained by calling 1-800-548-4725 or by visiting Intel's website at <http://www.intel.com>. Additional information on this product family can be obtained by accessing the Intel® Flash website: <http://www.intel.com/design/flash>.

Copyright © 2003 Intel Corporation.

\*Other names and brands may be claimed as the property of others.

# Contents

---

<b>1.0</b>	<b>Introduction</b> .....	7
1.1	Document Conventions .....	7
1.2	Product Overview .....	7
1.3	Package Ballout.....	8
1.4	Signal Definitions .....	9
<b>2.0</b>	<b>Principles of Operation</b> .....	11
2.1	Bus Operation.....	11
2.1.1	Read .....	11
2.1.2	Output Disable .....	12
2.1.3	Standby.....	12
2.1.4	Flash Reset.....	13
2.1.5	Write .....	13
<b>3.0</b>	<b>Flash Memory Modes of Operation</b> .....	13
3.1	Read Array (FFh).....	13
3.2	Read Identifier (90h) .....	13
3.3	Read Status Register (70h) .....	14
3.3.1	Clear Status Register (50h) .....	14
3.4	CFI Query (98h).....	15
3.5	Word Program (40h/10h) .....	15
3.5.1	Suspending and Resuming Program (B0h/D0h).....	15
3.6	Block Erase (20h) .....	16
3.6.1	Suspending and Resuming Erase (B0h/D0h).....	16
3.7	Block Locking.....	18
3.7.1	Block Locking Operation Summary.....	19
3.7.2	Locked State .....	19
3.7.3	Unlocked State .....	19
3.7.4	Lock-Down State .....	19
3.7.5	Reading a Block's Lock Status .....	20
3.7.6	Locking Operation during Erase Suspend .....	20
3.7.7	Status Register Error Checking .....	20
3.8	128 Bit Protection Register .....	21
3.8.1	Reading the Protection Register.....	21
3.8.2	Programming the Protection Register (C0h).....	21
3.8.3	Locking the Protection Register.....	22
<b>4.0</b>	<b>Power and Reset Considerations</b> .....	23
4.1	Power-Up/Down Characteristics.....	23
4.2	Additional Flash Features .....	23
4.2.1	Improved 12 Volt Production Programming .....	23
4.2.2	F-VPP < VPLK for Complete Protection .....	23
<b>5.0</b>	<b>Electrical Specifications</b> .....	24
5.1	Absolute Maximum Ratings .....	24
5.2	Operating Conditions .....	25
5.3	Capacitance.....	25



5.4	DC Characteristics.....	26
5.5	Flash AC Characteristics.....	29
5.6	Flash AC Characteristics—Write Operations.....	31
5.7	Flash Erase and Program Timings(1).....	31
5.8	Flash Reset Operations.....	34
5.9	SRAM AC Characteristics—Read Operations.....	35
5.10	SRAM AC Characteristics—Write Operations.....	37
5.11	SRAM Data Retention Characteristics—Extended Temperature.....	39
<b>6.0</b>	<b>Migration Guide Information.....</b>	<b>40</b>
<b>7.0</b>	<b>System Design Considerations.....</b>	<b>41</b>
7.1	Background.....	41
7.1.1	Flash + SRAM Footprint Integration.....	41
7.1.2	Advanced+ Boot Block Flash Memory Features.....	41
7.2	Flash Control Considerations.....	41
7.2.1	F-RP# Connected to System Reset.....	42
7.2.2	F-VCC, F-VPP and F-RP# Transition.....	42
7.3	Noise Reduction.....	43
7.4	Simultaneous Operation.....	44
7.4.1	SRAM Operation during Flash “Busy”.....	45
7.4.2	Simultaneous Bus Operations.....	45
7.5	Printed Circuit Board Notes.....	45
7.6	System Design Notes Summary.....	45
<b>Appendix A</b>	<b>Program/Erase Flowcharts.....</b>	<b>46</b>
<b>Appendix B</b>	<b>CFI Query Structure.....</b>	<b>52</b>
<b>Appendix C</b>	<b>Word-Wide Memory Map Diagrams.....</b>	<b>59</b>
<b>Appendix D</b>	<b>Device ID Table.....</b>	<b>62</b>
<b>Appendix E</b>	<b>Protection Register Addressing.....</b>	<b>63</b>
<b>Appendix F</b>	<b>Mechanical and Shipping Media Details.....</b>	<b>64</b>
<b>Appendix G</b>	<b>Additional Information.....</b>	<b>68</b>
<b>Appendix H</b>	<b>Ordering Information.....</b>	<b>69</b>

## Revision History

---

Date of Revision	Version	Description
02/11/03	-001	Initial release, Stacked-Chip Scale Package





## 1.0 Introduction

---

This document contains the specifications for the 3 Volt Intel® Advanced+ Boot Block Flash Memory (C3) Stacked-Chip Scale Package (Stacked-CSP) device. Stacked memory solutions are offered in the following combinations: 32-Mbit flash + 8-Mbit SRAM, 32-Mbit flash + 4-Mbit SRAM, 16-Mbit flash + 4-Mbit SRAM, or 16-Mbit flash memory + 2-Mbit SRAM.

### 1.1 Document Conventions

Throughout this document, the following conventions have been adopted.

- **Voltages:** “2.7 V” refers to the full voltage range, 2.7 V–3.3V; 12 V refers to 11.4 V to 12.6 V
- **Main block(s):** 32-Kword block
- **Parameter block(s):** 4-Kword block

### 1.2 Product Overview

The C3 Stacked-CSP device combines flash and SRAM into a single package, and provides secure low-voltage memory solutions for portable applications. This memory family combines two memory technologies, flash memory and SRAM, in one package. The flash memory delivers enhanced security features, a block locking capability that allows instant locking/unlocking of any flash block with zero-latency, and a 128-bit protection register that enable unique device identification, to meet the needs of next generation portable applications. Improved 12 V production programming can be used to improve factory throughput.

**Table 1. Block Organization (x16)**

Memory Device	Kwords
32-Mbit Flash	2048
16-Mbit Flash	1024
2-Mbit SRAM	128
4-Mbit SRAM	256
8-Mbit SRAM	512

**NOTE:** All words are 16 bits each.

The flash memory is asymmetrically-blocked to enable system integration of code and data storage in a single device. Each flash block can be erased independently of the others up to 100,000 times. The flash has eight 8-KB parameter blocks located at either the top (denoted by -T suffix) or the bottom (-B suffix) of the address map in order to accommodate different microprocessor protocols for kernel code location. The remaining flash memory is grouped into 32-Kword main blocks. Any individual flash block can be locked or unlocked instantly to provide complete protection for code or data (see [Section 5.7, “Flash Erase and Program Timings\(1\)”](#) on page 31 for details).

The flash contains both a Command User Interface (CUI) and a Write State Machine (WSM). The CUI serves as the interface between the microcontroller and the internal operation of the flash memory. The internal WSM automatically executes the algorithms and timings necessary for

program and erase operations, including verification, thereby unburdening the microprocessor or microcontroller. The flash’s status register indicates the status of the WSM by signifying block erase or word program completion and status.

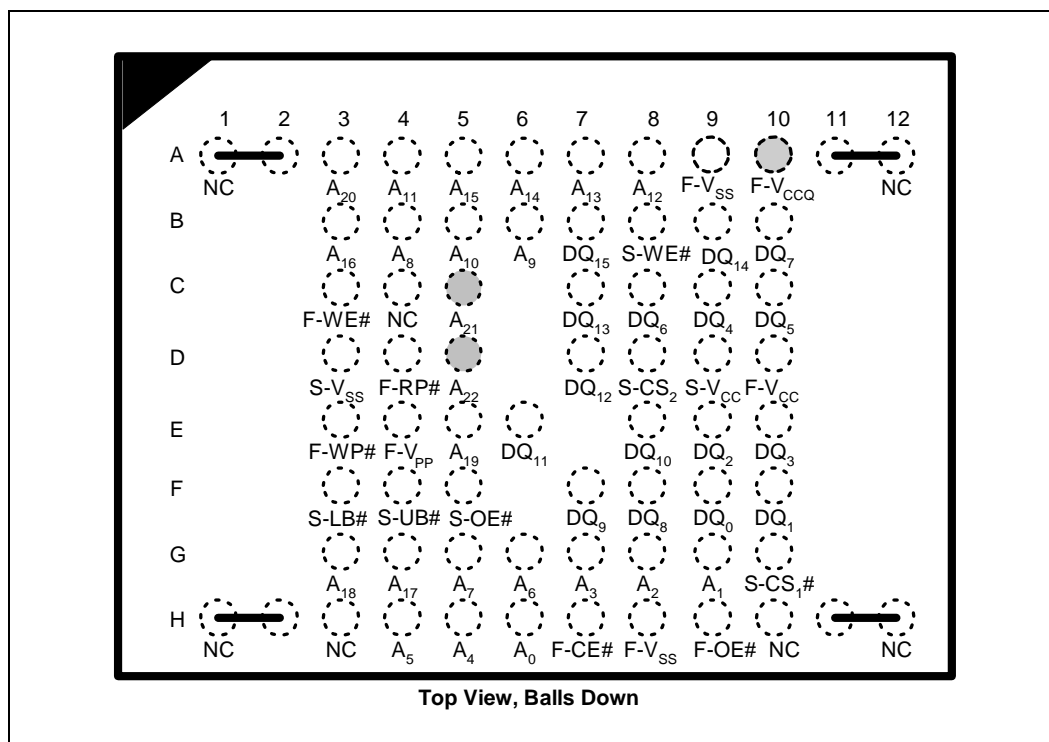
Flash program and erase automation allows program and erase operations to be executed using an industry-standard two-write command sequence to the CUI. Program operations are performed in word increments. Erase operations erase all locations within a block simultaneously. Both program and erase operations can be suspended by the system software in order to read from any other flash block. In addition, data can be programmed to another flash block during an erase suspend.

The C3 Stacked-CSP memory device offers two low-power savings features: Automatic Power Savings (APS) for flash memory and standby mode for flash and SRAM. The device automatically enters APS mode following the completion of a read cycle from the flash memory. Standby mode is initiated when the system deselects the device by driving F-CE# and S-CS1# or S-CS2 inactive. Power savings features significantly reduce power consumption.

The flash memory can be reset by lowering F-RP# to GND. This provides CPU-memory reset synchronization and additional protection against bus noise that may occur during system reset and power-up/-down sequences.

### 1.3 Package Ballout

Figure 1. 66-Ball Stacked Chip Scale Package



**NOTES:**

- Flash upgrade balls are shown up to A21 (64-Mbit flash) and A22 (128-Mbit flash). In all flash and SRAM combinations, 66 balls are populated on lower density devices. (Upper address balls are not populated). Ball location A10 is "NC" on 16/2 devices only.





### 3 Volt Intel® Advanced+ Boot Block Flash Memory Stacked-CSP Family

2. To maintain compatibility with all JEDEC Variation B options for this ball location C6, this C6 land pad should be connected directly to the land pad for ball G4 (A17).

## 1.4 Signal Definitions

Table 2. defines the signal definitions shown in the previous ballout.

**Table 2. 3 Volt Intel® Advanced+ Boot Block Stacked-CSP Ball Descriptions (Sheet 1 of 2)**

Symbol	Type	Name and Function
A[20:0]	INPUT	<b>ADDRESS INPUTS</b> for memory addresses. Addresses are internally latched during a program or erase cycle. 2-Mbit : A[16:0] 4-Mbit : A[18:0] 16-Mbit : A[19:0] 32-Mbit A[20:0]
DQ[15:0]	INPUT / OUTPUT	<b>DATA INPUTS/OUTPUTS:</b> Inputs array data for SRAM write operations and on the second F-CE# and F-WE# cycle during a flash program command. Inputs commands to the flash's Command User Interface when F-CE# and F-WE# are asserted. Data is internally latched. Outputs array, configuration and status register data. The data balls float to tri-state when the chip is de-selected or the outputs are disabled.
F-CE#	INPUT	<b>FLASH CHIP ENABLE:</b> Activates the flash internal control logic, input buffers, decoders and sense amplifiers. F-CE# is active low. F-CE# high de-selects the flash memory device and reduces power consumption to standby levels.
S-CS1#	INPUT	<b>SRAM CHIP SELECT1:</b> Activates the SRAM internal control logic, input buffers, decoders and sense amplifiers. S-CS1# is active low. S-CS1# high de-selects the SRAM memory device and reduces power consumption to standby levels.
S-CS2	INPUT	<b>SRAM CHIP SELECT2:</b> Activates the SRAM internal control logic, input buffers, decoders and sense amplifiers. S-CS2 is active high. S-CS2 low de-selects the SRAM memory device and reduces power consumption to standby levels.
F-OE#	INPUT	<b>FLASH OUTPUT ENABLE:</b> Enables flash's outputs through the data buffers during a read operation. F-OE# is active low.
S-OE#	INPUT	<b>SRAM OUTPUT ENABLE:</b> Enables SRAM's outputs through the data buffers during a read operation. S-OE# is active low.
F-WE#	INPUT	<b>FLASH WRITE ENABLE:</b> Controls writes to flash's command register and memory array. F-WE# is active low. Addresses and data are latched on the rising edge of the second F-WE# pulse.
S-WE#	INPUT	<b>SRAM WRITE ENABLE:</b> Controls writes to the SRAM memory array. S-WE# is active low.
S-UB#	INPUT	<b>SRAM UPPER BYTE ENABLE:</b> Enables the upper byte for SRAM (DQ <sub>8</sub> -DQ <sub>15</sub> ). S-UB# is active low.
S-LB#	INPUT	<b>SRAM LOWER BYTE ENABLE:</b> Enables the lower byte for SRAM (DQ <sub>0</sub> -DQ <sub>7</sub> ). S-LB# is active low.
F-RP#	INPUT	<b>FLASH RESET/DEEP POWER-DOWN:</b> Uses two voltage levels ( $V_{IL}$ , $V_{IH}$ ) to control reset/deep power-down mode. <b>When F-RP# is at logic low, the device is in reset/deep power-down mode</b> , which drives the outputs to High-Z, resets the Write State Machine, and minimizes current levels ( $I_{CCD}$ ). <b>When F-RP# is at logic high, the device is in standard operation.</b> When F-RP# transitions from logic-low to logic-high, the device resets all blocks to locked and defaults to the read array mode.

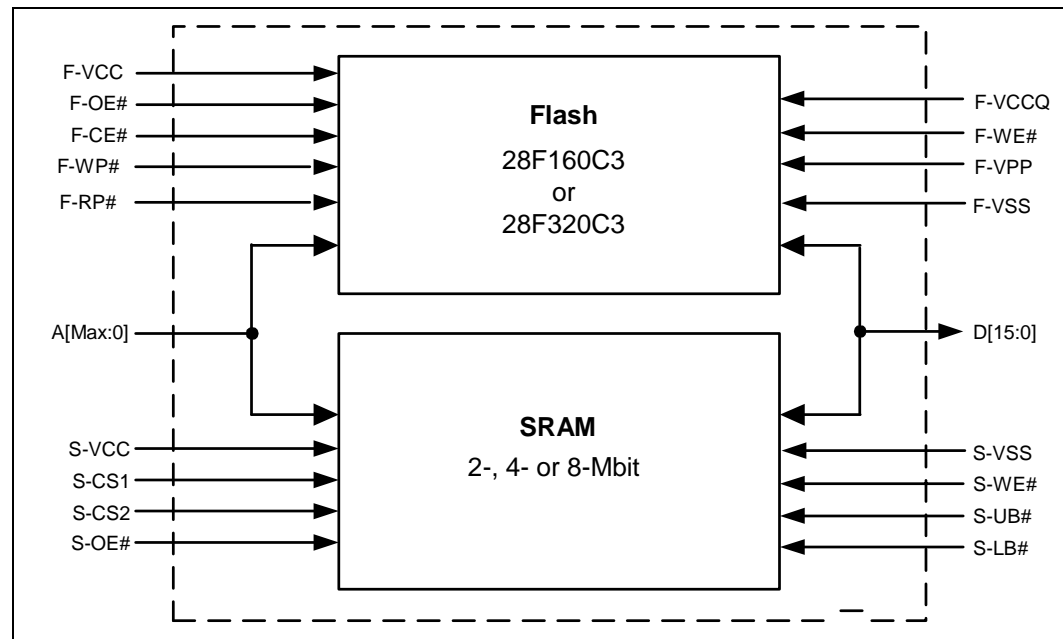
Table 2. 3 Volt Intel® Advanced+ Boot Block Stacked-CSP Ball Descriptions (Sheet 2 of 2)

Symbol	Type	Name and Function
F-WP#	INPUT	<p><b>FLASH WRITE PROTECT:</b> Controls the lock-down function of the flexible Locking feature.</p> <p><b>When F-WP# is a logic low, the lock-down mechanism is enabled</b> and blocks marked lock-down cannot be unlocked through software.</p> <p><b>When F-WP# is logic high, the lock-down mechanism is disabled</b> and blocks previously locked-down are now locked and can be unlocked and locked through software. After F-WP# goes low, any blocks previously marked lock-down revert to that state.</p> <p>See <a href="#">Section 7.0, “System Design Considerations” on page 41</a> for details on block locking.</p>
F-VCC	SUPPLY	<b>FLASH POWER SUPPLY:</b> [2.7 V–3.3 V] Supplies power for device core operations.
F-VCCQ	SUPPLY	<b>FLASH I/O POWER SUPPLY:</b> [2.7 V–3.3 V] Supplies power for device I/O operations.
S-VCC	SUPPLY	<p><b>SRAM POWER SUPPLY:</b> [2.7 V–3.3 V] Supplies power for device operations.</p> <p>See <a href="#">Section 7.2.2, “F-VCC, F-VPP and F-RP# Transition” on page 42</a> for details of power connections.</p>
F-VPP	INPUT / SUPPLY	<p><b>FLASH PROGRAM/ERASE POWER SUPPLY:</b> [1.65 V–3.3 V or 11.4 V–12.6 V] Operates as an input at logic levels to control complete flash protection. Supplies power for accelerated flash program and erase operations in 12 V ± 5% range. This ball cannot be left floating.</p> <p><b>Lower F-V<sub>PP</sub> ≤ V<sub>PPLK</sub>,</b> to protect all contents against Program and Erase commands.</p> <p><b>Set F-V<sub>PP</sub> = F-V<sub>CC</sub> for in-system read, program and erase operations.</b> In this configuration, F-V<sub>PP</sub> can drop as low as 1.65 V to allow for resistor or diode drop from the system supply. Note that if F-V<sub>PP</sub> is driven by a logic signal, V<sub>IH</sub> = 1.65 V. That is, F-V<sub>PP</sub> must remain above 1.65 V to perform in-system flash modifications.</p> <p><b>Raise F-V<sub>PP</sub> to 12 V ± 5% for faster program and erase in a production environment.</b> Applying 12 V ± 5% to F-V<sub>PP</sub> can only be done for a maximum of 1000 cycles on the main blocks and 2500 cycles on the parameter blocks. F-V<sub>PP</sub> may be connected to 12 V for a total of 80 hours maximum.</p>
F-VSS	SUPPLY	<b>FLASH GROUND:</b> For all internal circuitry. All ground inputs <b>must</b> be connected.
S-VSS	SUPPLY	<b>SRAM GROUND:</b> For all internal circuitry. All ground inputs <b>must</b> be connected.
NC		<b>NOT CONNECTED:</b> Internally disconnected within the device.

## 2.0 Principles of Operation

The flash memory utilizes a CUI and automated algorithms to simplify program and erase operations. The WSM automates program and erase operations by handling data and address latches, WE#, and system status requests.

Figure 2. 3 Volt Intel® Advanced+ Boot Block Stacked Chip Scale Package Block Diagram



### 2.1 Bus Operation

All bus cycles to or from the Stacked-CSP conform to standard microcontroller bus cycles. Four control signals dictate the data flow in and out of the flash component: F-CE#, F-OE#, F-WE# and F-RP#. Four separate control signals handle the data flow in and out of the SRAM component: S-CS1#, S-CS2, S-OE#, and S-WE#. These bus operations are summarized in [Table 2](#) and [Table 3](#).

#### 2.1.1 Read

The flash memory has four read modes: read array, read identifier, read status and CFI query. These flash memory read modes are not dependent on the F-V<sub>PP</sub> voltage. Upon initial device power-up or after exit from reset, the flash device automatically defaults to read array mode. F-CE# and F-OE# must be asserted to obtain data from the flash component.

The SRAM has one read mode available. S-CS1#, S-CS2, and S-OE# must be asserted to obtain data from the SRAM device. See [Table 3, “3 Volt Intel Advanced+ Boot Block Flash Memory Stacked-CSP Bus Operations”](#) on page 12 for a summary of operations.

Table 3. 3 Volt Intel Advanced+ Boot Block Flash Memory Stacked-CSP Bus Operations

	Modes	Flash Signals				SRAM Signals					Memory Output		Notes
		F-RP#	F-CE#	F-OE1#	F-WE#	S-CS1#	S-CS2	S-OE1#	S-WE#	S-UB#,S-LB#(1)	Memory Bus Control	D <sub>0</sub> - D <sub>15</sub>	
FLASH	Read	H	L	L	H	SRAM must be in High Z					Flash	D <sub>OUT</sub>	2,3,4
	Write	H	L	H	L	SRAM must be in High Z					Flash	D <sub>IN</sub>	2,4
	Standby	H	H	X	X	Any SRAM mode is allowable					Other	High Z	5,6
	Output Disable	H	L	H	H	Any SRAM mode is allowable					Other	High Z	5,6
	Reset	L	X	X	X	Any SRAM mode is allowable					Other	High Z	5,6
SRAM	Read	FLASH must be in High Z				L	H	L	H	L	SRAM	D <sub>OUT</sub>	2,4
	Write	FLASH must be in High Z				L	H	H	L	L	SRAM	D <sub>IN</sub>	2,4
	Standby	Any FLASH mode is allowable				H	X	X	X	X	Other	High Z	4,5,6
		Any FLASH mode is allowable				X	L	X	X	X			
	Output Disable	Any FLASH mode is allowable				L	H	H	H	X	Other	High Z	4,5,6
Data Retention	Any FLASH mode is allowable				same as a standby					Other	High Z	4,5,7	

**NOTES:**

- Two devices may not drive the memory bus at the same time.
- The SRAM may be placed into data retention mode by lowering the S-V<sub>CC</sub> to the V<sub>DR</sub> range, as specified.

### 2.1.2 Output Disable

With F-OE# and S-OE# deasserted, the Stacked-CSP outputs signals are placed in a high-impedance state.

### 2.1.3 Standby

With F-CE# and S-CS1# or S-CS2 deasserted, the Stacked-CSP enters a standby mode, which substantially reduces device power consumption. In standby, outputs are placed in a high-impedance state independent of F-OE# and S-OE#. If the flash is deselected during a program or erase operation, the flash continues to consume active power until the program or erase operation is complete.

### 2.1.4 Flash Reset

The device enters a reset mode when RP# is driven low. In reset mode, internal circuitry is turned off and outputs are placed in a high-impedance state.

After return from reset, a time  $t_{PHQV}$  is required until outputs are valid, and a delay ( $t_{PHWL}$  or  $t_{PHEL}$ ) is required before a write sequence can be initiated. After this wake-up interval, normal operation is restored. The device defaults to read array mode, the status register is set to 80h, and the read configuration register defaults to asynchronous reads.

If RP# is taken low during a block erase or program operation, the operation will be aborted and the memory contents at the aborted location are no longer valid.

### 2.1.5 Write

Writes to flash take place when both F-CE# and F-WE# are asserted and F-OE# is deasserted. Writes to SRAM take place when both S-CS1# and S-WE# are asserted and S-OE# and S-CS2 are deasserted. Commands are written to the flash memory's Command User Interface (CUI) using standard microprocessor write timings to control flash operations. The CUI does not occupy an addressable memory location within the flash component. The address and data buses are latched on the rising edge of the second F-WE# or F-CE# pulse, whichever occurs first. (See [Figure 6](#) and [Figure 7](#) for read and write waveforms.)

## 3.0 Flash Memory Modes of Operation

---

The flash memory has four read modes: read array, read configuration, read status, and CFI query. The write modes are program and erase. Three additional modes (erase suspend to program, erase suspend to read and program suspend to read) are available only during suspended operations. These modes are reached using the commands summarized in [Table 5, "Flash Memory Command Definitions"](#) on page 17.

### 3.1 Read Array (FFh)

When F-RP# transitions from  $V_{IL}$  (reset) to  $V_{IH}$ , the device defaults to read array mode and will respond to the read control inputs without any additional CUI commands.

In addition, the address of the desired location must be applied to the address balls. If the device is not in read array mode, as would be the case after a program or erase operation, the Read Array command (FFh) must be written to the CUI before array reads can take place.

### 3.2 Read Identifier (90h)

The read configuration mode outputs the manufacturer/device identifier. The device is switched to this mode by writing the read configuration command (90h). Once in this mode, read cycles from addresses shown in [Table 4, "Read Configuration Table"](#) on page 14 retrieve the specified information. To return to read array mode, write the Read Array command (FFh).

The Read Configuration mode outputs three types of information: the manufacturer/device identifier, the block locking status, and the protection register. The device is switched to this mode by writing the Read Configuration command (90h). Once in this mode, read cycles from addresses shown in Table 4 retrieve the specified information. To return to read array mode, write the Read Array command (FFh).

**Table 4. Read Configuration Table**

Item	Address	Data	Notes
Manufacturer Code (x16)	0x00000	0x0089	
Device ID (See Appendix D)	0x00001	ID	
Block Lock Configuration <ul style="list-style-type: none"> <li>Block Is Unlocked</li> <li>Block Is Locked</li> <li>Block Is Locked-Down</li> </ul>	0xXX002	LOCK	1, 2
		DQ <sub>0</sub> = 0	
		DQ <sub>0</sub> = 1	
		DQ <sub>1</sub> = 1	
Protection Register Lock	0x80	PR-LK	3
Protection Register (x16)	0x81-0x88	PR	

**NOTES:**

1. See [Section 3.7](#) for valid lock status outputs.
2. "XX" specifies the block address of lock configuration being read.
3. See [Section 3.8](#) for protection register information.

Other locations within the configuration address space are reserved by Intel for future use.

### 3.3 Read Status Register (70h)

The status register indicates the status of device operations, and the success/failure of that operation. The Read Status Register (70h) command causes subsequent reads to output data from the status register until another command is issued. To return to reading from the array, issue a Read Array (FFh) command.

The status register bits are output on DQ[7:0]. The upper byte, DQ[15:8], outputs 00h during a Read Status Register command.

The contents of the status register are latched on the falling edge of F-OE# or F-CE#, whichever occurs last. This prevents possible bus errors which might occur if status register contents change while being read. F-CE# or F-OE# must be toggled with each subsequent status read, or the status register will not indicate completion of a program or erase operation.

When the WSM is active, SR7 will indicate the status of the WSM; the remaining bits in the status register indicate whether the WSM was successful in performing the desired operation (see [Table 6, "Flash Memory Status Register Definition" on page 18](#)).

#### 3.3.1 Clear Status Register (50h)

The WSM sets status bits 1 through 7 to "1," and clears bits 2, 6 and 7 to "0," but cannot clear status bits 1 or 3 through 5 to "0." Because bits 1, 3, 4 and 5 indicate various error conditions, these bits can only be cleared through the use of the Clear Status Register (50h) command. By allowing the system software to control the resetting of these bits, several operations may be performed



(such as cumulatively programming several addresses or erasing multiple blocks in sequence) before reading the status register to determine if an error occurred during that series. Clear the status register before beginning another command or sequence. Note that the Read Array command must be issued before data can be read from the memory array. Resetting the device also clears the status register.

### 3.4 CFI Query (98h)

The CFI query mode outputs Common Flash Interface (CFI) data when the device is read. This can be accessed by writing the CFI Query Command (98h). The CFI data structure contains information such as block size, density, command set and electrical specifications. Once in this mode, read cycles from addresses shown in Appendix B retrieve the specified information. To return to read array mode, write the Read Array command (FFh).

### 3.5 Word Program (40h/10h)

Programming is executed using a two-write sequence. The Program Setup command (40h) is written to the CUI followed by a second write which specifies the address and data to be programmed. The WSM will execute a sequence of internally timed events to program desired bits of the addressed location, then verify the bits are sufficiently programmed. Programming the memory results in specific bits within an address location being changed to a “0.” If the user attempts to program “1”s, the memory cell contents do not change and no error occurs.

The status register indicates programming status: while the program sequence executes, status bit 7 is “0.” The status register can be polled by toggling either F-CE# or F-OE#. While programming, the only valid commands are Read Status Register, Program Suspend, and Program Resume.

When programming is complete, the program status bits should be checked. If the programming operation was unsuccessful, bit SR.4 of the status register is set to indicate a program failure. If SR.3 is set then F-V<sub>PP</sub> was not within acceptable limits, and the WSM did not execute the program command. If SR.1 is set, a program operation was attempted on a locked block and the operation was aborted.

The status register should be cleared before attempting the next operation. Any CUI instruction can follow after programming is completed; however, to prevent inadvertent status register reads, be sure to reset the CUI to read array mode.

#### 3.5.1 Suspending and Resuming Program (B0h/D0h)

The Program Suspend command halts an in-progress program operation so that data can be read from other locations of memory. Once the programming process starts, writing the Program Suspend command to the CUI requests that the WSM suspend the program sequence (at predetermined points in the program algorithm). The device continues to output status register data after the Program Suspend command is written. Polling status register bits SR.7 and SR.2 will determine when the program operation has been suspended (both will be set to “1”). t<sub>WHRH1</sub>/t<sub>EHRH1</sub> specify the program suspend latency.

A Read Array command can be written to the CUI to read data from any block other than the suspended block. The only other valid commands, while program is suspended, are Read Status Register, Read Configuration, CFI Query, and Program Resume. After the Program Resume

command is written to the flash memory, the WSM will continue with the programming process and status register bits SR.2 and SR.7 will automatically be cleared. The device automatically outputs status register data when read (see Appendix A, *Program Suspend/Resume Flowcharts*) after the Program Resume command is written. F-V<sub>PP</sub> must remain at the same F-V<sub>PP</sub> level used for program while in program suspend mode. F-RP# must also remain at V<sub>IH</sub>.

## 3.6 Block Erase (20h)

To erase a block, write the Erase Set-up and Erase Confirm commands to the CUI, along with an address identifying the block to be erased. This address is latched internally when the Erase Confirm command is issued. Block erasure results in all bits within the block being set to “1.” Only one block can be erased at a time. The WSM will execute a sequence of internally timed events to program all bits within the block to “0,” erase all bits within the block to “1,” then verify that all bits within the block are sufficiently erased. While the erase executes, status bit 7 is a “0.”

When the status register indicates that erasure is complete, check the erase status bit to verify that the erase operation was successful. If the Erase operation was unsuccessful, SR.5 of the status register will be set to a “1,” indicating an erase failure. If F-V<sub>PP</sub> was not within acceptable limits after the Erase Confirm command was issued, the WSM will not execute the erase sequence; instead, SR.5 of the status register is set to indicate an erase error, and SR.3 is set to a “1” to identify that F-V<sub>PP</sub> supply voltage was not within acceptable limits.

After an erase operation, clear the status register (50h) before attempting the next operation. Any CUI instruction can follow after erasure is completed; however, to prevent inadvertent status register reads, it is advisable to place the flash in read array mode after the erase is complete.

### 3.6.1 Suspending and Resuming Erase (B0h/D0h)

An erase operation can take several seconds to complete, therefore, the Erase Suspend command is provided to allow erase-sequence interruption in order to read data from, or program data to, another block in memory. Once an erase sequence has started, writing the Erase Suspend command to the CUI causes the device to suspend the erase sequence at a predetermined point in the erase algorithm. Block erase is suspended when Status Register bits SR[7,6] are set. Suspend latency is specified in Section 5.7, “Flash Erase and Program Timings” on page 31.

When an erase operation has been suspended, a Word Program or Read operation can be performed within any block, except the block that is in an erase suspend state. An erase operation cannot be nested within another erase suspend operation.

A suspended erase operation cannot resume until the nested program operation has completed. Read Array, Read Status Register, Clear Status Register, Read Identifier, CFI Query, Erase Resume, are all valid commands during Erase Suspend. Additionally, Program, Program Suspend, Program Resume, Lock Block, Unlock Block and Lock-Down Block are valid commands during Erase Suspend.

To resume an erase suspend operation, issue the Resume command. The Resume command can be written to any device address. When a program operation is nested within an Erase Suspend operation and the Program Suspend command is issued, the device will suspend the program operation. When the resume command is issued, the device will resume the program operation first. Once the nested program operation is completed, an additional Resume command is required to complete the block operation.





**Table 5. Flash Memory Command Definitions**

Command	Note	First Bus Cycle			Second Bus Cycle		
		Operation	Address	Data	Operation	Address	Data
Read Array	1	Write	X	FFh			
Read Identifier	1, 2	Write	X	90h	Read	IA	ID
CFI Query	1, 2	Write	X	98h	Read	QA	QD
Read Status Register	1	Write	X	70h	Read	X	SRD
Clear Status Register	1	Write	X	50h			
Word Program	1, 3	Write	X	40h/10h	Write	PA	PD
Block Erase/Confirm	1	Write	X	20h	Write	BA	D0h
Program/Erase Suspend	1	Write	X	B0h			
Program/Erase Resume	1	Write	X	D0h			
Lock Block	1	Write	X	60h	Write	BA	01h
Unlock Block	1, 4	Write	X	60h	Write	BA	D0h
Lock-Down Block	1	Write	X	60h	Write	BA	2Fh
Protection Register Program	1	Write	X	C0h	Write	PA	PD
Lock Protection Register	1	Write	X	C0h	Write	PA	FFFD

X = Don't Care      PA = Program Address    BA = Block Address    IA = Identifier Address    QA = Query Address  
 SRD = Status Register Data    PD = Program Data      ID = Identifier Data      QD = Query Data

**NOTES:**

1. When writing commands, the upper data bus [DQ<sub>8</sub>–DQ<sub>15</sub>] should be either V<sub>IL</sub> or V<sub>IH</sub>, to minimize current draw.
2. Following the Read Configuration or CFI Query commands, read operations output device configuration or CFI query information, respectively.
3. Either 40h or 10h command is valid, but the Intel standard is 40h.
4. When unlocking a block, WP# must be held for three clock cycles (1 clock cycle after the second command bus cycle).

**Table 6. Flash Memory Status Register Definition**

WSMS	ESS	ES	PS	VPPS	PSS	BLS	R
7	6	5	4	3	2	1	0
				<b>NOTES:</b>			
SR.7 WRITE STATE MACHINE STATUS 1 = Ready (WSMS) 0 = Busy				Check Write State Machine bit first to determine Word Program or Block Erase completion, before checking Program or Erase Status bits.			
SR.6 = ERASE-SUSPEND STATUS (ESS) 1 = Erase Suspended 0 = Erase In Progress/Completed				When Erase Suspend is issued, WSM halts execution and sets both WSMS and ESS bits to "1." ESS bit remains set to "1" until an Erase Resume command is issued.			
SR.5 = ERASE STATUS (ES) 1 = Error In Block Erase 0 = Successful Block Erase				When this bit is set to "1," WSM has applied the max. number of erase pulses and is still unable to verify successful block erasure.			
SR.4 = PROGRAM STATUS (PS) 1 = Error in Programming 0 = Successful Programming				When this bit is set to "1," WSM has attempted but failed to program a word/byte.			
SR.3 = F-V <sub>PP</sub> STATUS (VPPS) 1 = F-V <sub>PP</sub> Low Detect, Operation Abort 0 = F-V <sub>PP</sub> OK				The F-V <sub>PP</sub> status bit does not provide continuous indication of V <sub>PP</sub> level. The WSM interrogates F-V <sub>PP</sub> level only after the Program or Erase command sequences have been entered, and informs the system if F-V <sub>PP</sub> has not been switched on. The F-V <sub>PP</sub> is also checked before the operation is verified by the WSM. The F-V <sub>PP</sub> status bit is not guaranteed to report accurate feedback between V <sub>PPLK</sub> and V <sub>PP1 min</sub> .			
SR.2 = PROGRAM SUSPEND STATUS (PSS) 1 = Program Suspended 0 = Program in Progress/Completed				When Program Suspend is issued, WSM halts execution and sets both WSMS and PSS bits to "1." PSS bit remains set to "1" until a Program Resume command is issued.			
SR.1 = BLOCK LOCK STATUS 1 = Prog/Erase attempted on a locked block; Operation aborted. 0 = No operation to locked blocks				If a program or erase operation is attempted to one of the locked blocks, this bit is set by the WSM. The operation specified is aborted and the device is returned to read status mode.			
SR.0 = RESERVED FOR FUTURE ENHANCEMENTS (R)				This bit is reserved for future use and should be masked out when polling the status register.			

**NOTE:** A Command Sequence Error is indicated when SR.4, SR.5 and SR.7 are set.

### 3.7 Block Locking

The instant, individual block locking feature that allows any flash block to be locked or unlocked with no latency, which enables instant code and data protection.

This locking offers two levels of protection. The first level allows software-only control of block locking (useful for data blocks that change frequently), while the second level requires hardware interaction before locking can be changed (useful for code blocks that change infrequently).

The following sections will discuss the operation of the locking system. The term "state [XYZ]" will be used to specify locking states; e.g., "state [001]," where X = value of WP#, Y = bit DQ<sub>1</sub> of the Block Lock status register, and Z = bit DQ<sub>0</sub> of the Block Lock status register. [Table 8, "Block Locking State Transitions" on page 21](#) defines all of these possible locking states.

### 3.7.1 Block Locking Operation Summary

The following concisely summarizes the locking functionality.

All blocks are locked when powered-up, and can be unlocked or locked with the Unlock and Lock commands.

- The Lock-Down command locks a block and prevents it from being unlocked when WP# = 0.
- When WP# = 1, Lock-Down is overridden and commands can unlock/lock locked-down blocks.
- When WP# returns to 0, locked-down blocks return to Lock-Down.
- Lock-Down is cleared only when the device is reset or powered-down.

The locking status of each block can set to Locked, Unlocked, and Lock-Down, each of which will be described in the following sections. A comprehensive state table for the locking functions is shown in [Table 8 on page 21](#), and a flowchart for locking operations is shown in [Figure 19 on page 50](#).

### 3.7.2 Locked State

The default status of all blocks upon power-up or reset is locked (states [001] or [101]). Locked blocks are fully protected from alteration. Any program or erase operations attempted on a locked block will return an error on bit SR.1 of the status register. The status of a locked block can be changed to Unlocked or Lock-Down using the appropriate software commands. Unlocked blocks can be locked issuing the “Lock” command sequence, 60h followed by 01h.

### 3.7.3 Unlocked State

Unlocked blocks (states [000], [100], [110]) can be programmed or erased. All unlocked blocks return to the Locked state when the device is reset or powered down. The status of an unlocked block can be changed to Locked or Locked-Down using the appropriate software commands. A Locked block can be unlocked by writing the Unlock command sequence, 60h followed by D0h.

### 3.7.4 Lock-Down State

Blocks that are Locked-Down (state [011]) are protected from program and erase operations (just like Locked blocks), but their protection status cannot be changed using software commands alone. A Locked or Unlocked block can be Locked-down by writing the Lock-Down command sequence, 60h followed by 2Fh. Locked-Down blocks revert to the Locked state when the device is reset or powered down.

The Lock-Down function is dependent on the WP# input ball. When WP# = 0, blocks in Lock-Down [011] are protected from program, erase, and lock status changes. When WP# = 1, the Lock-Down function is disabled ([111]) and locked-down blocks can be individually unlocked by software command to the [110] state, where they can be erased and programmed. These blocks can then be re-locked [111] and unlocked [110] as desired while WP# remains high. When WP# goes low, blocks that were previously locked-down return to the Lock-Down state [011] regardless of any changes made while WP# was high. Device reset or power-down resets all blocks, including those in Lock-Down, to Locked state.

### 3.7.5 Reading a Block's Lock Status

The lock status of every block can be read in the configuration read mode of the device. To enter this mode, write 90h to the device. Subsequent reads at Block Address + 00002 will output the lock status of that block. The lock status is represented by the least significant outputs, DQ<sub>0</sub> and DQ<sub>1</sub>. DQ<sub>0</sub> indicates the Block Lock/Unlock status and is set by the Lock command and cleared by the Unlock command. It is also automatically set when entering Lock-Down. DQ<sub>1</sub> indicates Lock-Down status and is set by the Lock-Down command. It cannot be cleared by software, only by device reset or power-down.

**Table 7. Block Lock Status**

Item	Address	Data
Block Lock Configuration	XX002	LOCK
• Block Is Unlocked		DQ <sub>0</sub> = 0
• Block Is Locked		DQ <sub>0</sub> = 1
• Block Is Locked-Down		DQ <sub>1</sub> = 1

### 3.7.6 Locking Operation during Erase Suspend

Changes to block lock status can be performed during an erase suspend by using the standard locking command sequences to unlock, lock, or lock-down a block. This is useful in the case when another block needs to be updated while an erase operation is in progress.

To change block locking during an erase operation, first write the erase suspend command (B0h), then check the status register until it indicates that the erase operation has been suspended. Next write the desired lock command sequence to a block and the lock status will be changed. After completing any desired lock, read, or program operations, resume the erase operation with the Erase Resume command (D0h).

If a block is locked or locked-down during a suspended erase of the same block, the locking status bits will be changed immediately, but when the erase is resumed, the erase operation will complete.

Locking operations cannot be performed during a program suspend.

### 3.7.7 Status Register Error Checking

Using nested locking or program command sequences during erase suspend can introduce ambiguity into status register results.

Since locking changes are performed using a two cycle command sequence, e.g., 60h followed by 01h to lock a block, following the Configuration Setup command (60h) with an invalid command will produce a lock command error (SR.4 and SR.5 will be set to 1) in the status register. If a lock command error occurs during an erase suspend, SR.4 and SR.5 will be set to 1, and will remain at 1 after the erase is resumed. When erase is complete, any possible error during the erase cannot be detected via the status register because of the previous locking command error.

A similar situation happens if an error occurs during a program operation error nested within an erase suspend.

**Table 8. Block Locking State Transitions**

Current State				Erase/ Program Allowed?	Next State after Command Input		
WP#	DQ <sub>1</sub>	DQ <sub>0</sub>	Name		Lock	Unlock	Lock-Down
0	0	0	Unlocked	Yes	Go To [001]	–	Go To [011]
1	0	0	Unlocked	Yes	Go To [101]	–	Go To [111]
0	0	1	Locked (Default)	No	–	Go To [000]	Go To [011]
1	0	1	Locked	No	–	Go To [100]	Go To [111]
0	1	1	Locked-Down	No	–	–	–
1	1	0	Lock-Down Disabled	Yes	Go To [111]	–	Go To [111]
1	1	1		No	–	Go To [110]	–

**NOTES:**

1. “–” indicates no change in the current state.
2. In this table, the notation [XYZ] denotes the locking state of a block, where X = WP#, Y = DQ<sub>1</sub>, and Z = DQ<sub>0</sub>. The current locking state of a block is defined by the state of WP# and the two bits of the block lock status (DQ<sub>0</sub>, DQ<sub>1</sub>). DQ<sub>0</sub> indicates if a block is locked (1) or unlocked (0). DQ<sub>1</sub> indicates if a block has been locked-down (1) or not (0).
3. At power-up or device reset, all blocks default to Locked state [001] (if WP# = 0). holding WP# = 0 is the recommended default.
4. The “Erase/Program Allowed?” column shows whether erase and program operations are enabled (Yes) or disabled (No) in that block’s current locking state.
5. The “Lock Command Input Result [Next State]” column shows the result of writing the three locking commands (Lock, Unlock, Lock-Down) in the current locking state. For example, “Goes To [001]” would mean that writing the command to a block in the current locking state would change it to [001].
6. The 128 bits of the protection register are divided into two 64-bit segments. One of the segments is programmed at the Intel factory with a unique 64 bit number, which is unchangeable. The other segment is left blank for customer designs to program as desired. Once the customer segment is programmed, it can be locked to prevent reprogramming.

### 3.8 128 Bit Protection Register

The 3 Volt Intel® Advanced+ Stacked-CSP architecture includes a 128-bit protection register that can be used to increase the security of a system design. For example, the number contained in the protection register can be used to “mate” the flash component with other system components such as the CPU or ASIC, preventing device substitution.

#### 3.8.1 Reading the Protection Register

The protection register is read in the configuration read mode. The device is switched to this mode by writing the Read Configuration command (90h). Once in this mode, read cycles from addresses shown in Appendix E retrieve the specified information. To return to read array mode, write the Read Array command (FFh).

#### 3.8.2 Programming the Protection Register (C0h)

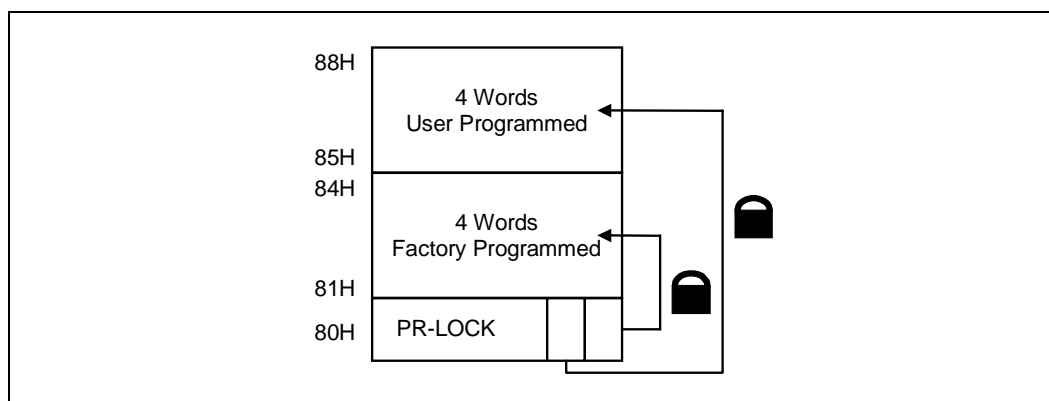
The protection register bits are programmed using the two-cycle Protection Program command. The 64-bit number is programmed 16 bits at a time for word-wide parts. First write the Protection Program Setup command, C0h. The next write to the device will latch in address and data and program the specified location. The allowable addresses are shown in Appendix E. See Figure 20, “Protection Register Programming Flowchart” on page 51.

Any attempt to address Protection Program commands outside the defined protection register address space will result in a status register error (program error bit SR.4 will be set to 1). Attempting to program or to a previously locked protection register segment will result in a status register error (program error bit SR.4 and lock error bit SR.1 will be set to 1).

### 3.8.3 Locking the Protection Register

The user-programmable segment of the protection register is lockable by programming Bit 1 of the PR-LOCK location to 0. Bit 0 of this location is programmed to 0 at the Intel factory to protect the unique device number. This bit is set using the Protection Program command to program FFFDh to the PR-LOCK location. After these bits have been programmed, no further changes can be made to the values stored in the protection register. A Protection Program command to locked words will result in a status register error (program error bit SR.4 and Lock Error bit SR.1 will be set to 1). The protection register lockout state is not reversible.

Figure 3. Protection Register Memory Map



0645\_05

## 4.0 Power and Reset Considerations

---

### 4.1 Power-Up/Down Characteristics

In order to prevent any condition that may result in a spurious write or erase operation, it is recommended to power-up F-VCC, F-VCCQ and S-VCC together. Conversely, F-VCC, F-VCCQ and S-VCC must power-down together. It is also recommended to power-up F-VPP with or slightly after F-VCC. Conversely, F-VPP must power down with or slightly before F-VCC.

If F-VCCQ and/or F-VPP are not connected to the F-VCC supply, then F-VCC should attain F-VCCMin before applying F-VCCQ and F-VPP. Device inputs should not be driven before supply voltage = F-VCCMin. Power supply transitions should only occur when F-RP# is low.

### 4.2 Additional Flash Features

Intel 3 Volt Advanced+ Stacked-CSP products provide in-system programming and erase in the 1.65 V–3.3 V range. For fast production programming, it also includes a low-cost, backward-compatible 12 V programming feature.

#### 4.2.1 Improved 12 Volt Production Programming

When F-V<sub>PP</sub> is between 1.65 V and 3.3 V, all program and erase current is drawn through the F-V<sub>CC</sub> signal. Note that if F-V<sub>PP</sub> is driven by a logic signal, V<sub>IH</sub> min = 1.65 V. That is, F-V<sub>PP</sub> must remain above 1.65 V to perform in-system flash modifications. When F-V<sub>PP</sub> is connected to a 12 V power supply, the device draws program and erase current directly from the F-V<sub>PP</sub> signal. This eliminates the need for an external switching transistor to control the voltage F-V<sub>PP</sub>. [Figure 12, “Example Power Supply Configurations” on page 42](#) shows examples of how the flash power supplies can be configured for various usage models.

The 12 V F-V<sub>PP</sub> mode enhances programming performance during the short period of time typically found in manufacturing processes; however, it is not intended for extended use. 12 V may be applied to F-V<sub>PP</sub> during program and erase operations for a maximum of 1000 cycles on the main blocks and 2500 cycles on the parameter blocks. F-V<sub>PP</sub> may be connected to 12 V for a total of 80 hours maximum. Stressing the device beyond these limits may cause permanent damage.

#### 4.2.2 F-V<sub>PP</sub> ≤ V<sub>PPLK</sub> for Complete Protection

In addition to the flexible block locking, the F-V<sub>PP</sub> programming voltage can be held low for absolute hardware write protection of all blocks in the flash device. When F-V<sub>PP</sub> is below V<sub>PPLK</sub>, any program or erase operation will result in an error, prompting the corresponding status register bit (SR.3) to be set.

## 5.0 Electrical Specifications

### 5.1 Absolute Maximum Ratings

**Warning:** Stressing the device beyond the “Absolute Maximum Ratings” may cause permanent damage. These are stress ratings only. Operation beyond the “Operating Conditions” is not recommended and extended exposure beyond the “Operating Conditions” may affect device reliability.

**NOTICE:** This datasheet contains information on products in full production. The specifications are subject to change without notice. Verify with your local Intel Sales office that you have the latest datasheet before finalizing a design.

**Table 9. Absolute Maximum Ratings**

Parameter	Maximum Rating	Notes
Extended Operating Temperature	-25°C to +85°C	
During Read		
During Flash Block Erase and Program		
Temperature under Bias		
Storage Temperature	-65°C to +125°C	
Voltage on Any Ball (except F-VCC/F-VCCQ/S-VCC and F-VPP) with Respect to GND	-0.5 V to +3.3 V	1
F-V <sub>PP</sub> Voltage (for Block Erase and Program) with Respect to GND	-0.5 V to +13.5 V	1,2,4
F-V <sub>CC</sub> / F-V <sub>CCQ</sub> / S-V <sub>CC</sub> Supply Voltage with Respect to GND	-0.2V to +3.3 V	
Output Short Circuit Current	100 mA	3

**NOTES:**

1. Minimum DC voltage is -0.5 V on input/output balls. During transitions, this level may undershoot to -2.0 V for periods < 20 ns. Maximum DC voltage on input/output balls is F-V<sub>CC</sub> / F-V<sub>CCQ</sub> / S-V<sub>CC</sub> + 0.5 V which, during transitions, may overshoot to F-V<sub>CC</sub> / F-V<sub>CCQ</sub> / S-V<sub>CC</sub> + 2.0 V for periods < 20 ns.
2. Maximum DC voltage on F-V<sub>PP</sub> may overshoot to +14.0 V for periods < 20 ns.
3. F-V<sub>PP</sub> voltage is normally 1.65 V–3.3 V. Connection to supply of 11.4 V–12.6 V can only be done for 1000 cycles on the main blocks and 2500 cycles on the parameter blocks during program/erase. F-V<sub>PP</sub> may be connected to 12 V for a total of 80 hours maximum. See [Section 4.2.1](#) for details
4. Output shorted for no more than one second. No more than one output shorted at a time.





## 5.2 Operating Conditions

Table 10. Temperature and Voltage Operating Conditions

Symbol	Parameter	Notes	Min	Max	Units
$T_{CASE}$	Operating Temperature		-25	+85	°C
$V_{CC} / V_{CCQ}$	F- $V_{CC}$ / F- $V_{CCQ}$ / S- $V_{CC}$ Supply Voltage	1	2.7	3.3	Volts
$V_{PP1}$	Supply Voltage	1	1.65	3.3	Volts
$V_{PP2}$		1, 2	11.4	12.6	Volts
Cycling	Block Erase Cycling	2	100,000		Cycles

**NOTES:**

1. F- $V_{CC}$ /F- $V_{CCQ}$  must share the same supply. F- $V_{CC}$ /S- $V_{CC}$  must share the same supply when not in data retention.
2. Applying F- $V_{PP} = 11.4\text{ V} - 12.6\text{ V}$  during a program/erase can only be done for a maximum of 1000 cycles on the main blocks and 2500 cycles on the parameter blocks. F- $V_{PP}$  may be connected to 12 V for a total of 80 hours maximum. See [Section 4.2.1](#) for details.

## 5.3 Capacitance

$T_{CASE} = +25^{\circ}\text{C}$ ,  $f = 1\text{ MHz}$

Sym	Parameter	Notes	Typ	Max	Units	Conditions
$C_{IN}$	Input Capacitance	1	16	18	pF	$V_{IN} = 0\text{ V}$
$C_{OUT}$	Output Capacitance	1	20	22	pF	$V_{OUT} = 0\text{ V}$

**NOTE:** Sampled, not 100% tested.

## 5.4 DC Characteristics

Table 11. DC Characteristics (Sheet 1 of 2)

Symbol	Parameter	Device	Note	2.7 V – 3.3 V		Unit	Test Conditions	
				Typ	Max			
I <sub>LI</sub>	Input Load Current	Flash/ SRAM	1		± 2	μA	F-V <sub>CC</sub> /S-V <sub>CC</sub> = V <sub>CC</sub> Max V <sub>IN</sub> = V <sub>CC</sub> Max or GND	
I <sub>LO</sub>	Output Leakage Current	Flash/ SRAM	1	0.2	± 10	μA	F-V <sub>CC</sub> /S-V <sub>CC</sub> = V <sub>CC</sub> Max V <sub>IN</sub> = V <sub>CC</sub> Max or GND	
I <sub>CCS</sub>	V <sub>CC</sub> Standby Current	0.25μm Flash	1	10	25	μA	F-V <sub>CC</sub> = V <sub>CC</sub> Max F-CE# = F-RP# = V <sub>CC</sub> F-WP# = V <sub>CC</sub> or GND V <sub>IN</sub> = V <sub>CC</sub> Max or GND	
		0.13μm and 0.18μm Flash	1	7	15			
		2-Mb SRAM	1	-	10	μA		S-V <sub>CC</sub> = V <sub>CC</sub> Max S-CS1# = V <sub>CC</sub> , S-CS2 = V <sub>CC</sub> or S-CS2 = GND V <sub>IN</sub> = V <sub>CC</sub> Max or GND
		4-Mb SRAM	1	-	15	μA		
		8-Mb SRAM	1	-	25	μA		
I <sub>CCD</sub>	V <sub>CC</sub> Deep Power-Down Current	0.25μm Flash	1	7	25	μA	F-V <sub>CC</sub> = V <sub>CC</sub> Max V <sub>IN</sub> = V <sub>CC</sub> Max or GND F-RP# = GND ± 0.2 V	
		0.13μm and 0.18μm Flash	1	7	15			
I <sub>CC</sub>	Operating Power Supply Current (cycle time = 1 μs)	2-Mb SRAM	1	-	7	mA	I <sub>O</sub> = 0 mA, S-CS1# = V <sub>IL</sub> S-CS2 = S-WE# = V <sub>IH</sub> V <sub>IN</sub> = V <sub>IL</sub> or V <sub>IH</sub>	
		4-Mb SRAM	1	-	10	mA		
		8-Mb SRAM	1	-	10	mA		
I <sub>CC2</sub>	Operating Power Supply Current (min cycle time)	2-Mb SRAM	1	-	40	mA	Cycle time = Min, 100% duty, I <sub>O</sub> = 0 mA, S-CS1# = V <sub>IL</sub> , S-CS2 = V <sub>IH</sub> , V <sub>IN</sub> = V <sub>IL</sub> or V <sub>IH</sub>	
		4-Mb SRAM	1	-	45	mA		
		8-Mb SRAM	1	-	50	mA		
I <sub>CCR</sub>	V <sub>CC</sub> Read Current	0.25μm Flash	1,2	10	18	mA	F-V <sub>CC</sub> = V <sub>CC</sub> Max F-OE# = V <sub>IH</sub> , F-CE# = V <sub>IL</sub> f = 5 MHz, I <sub>OUT</sub> = 0 mA V <sub>IN</sub> = V <sub>IL</sub> or V <sub>IH</sub>	
		0.13μm and 0.18μm Flash	1,2	9	18	mA		



Table 11. DC Characteristics (Sheet 2 of 2)

Symbol	Parameter	Device	Note	2.7 V – 3.3 V		Unit	Test Conditions
				Typ	Max		
I <sub>CCW</sub>	V <sub>CC</sub> Program Current	Flash	1,3	18	55	mA	F-V <sub>PP</sub> = V <sub>PP1</sub> Program in Progress
				8	22	mA	F-V <sub>PP</sub> = V <sub>PP2</sub> (12 V) Program in Progress
I <sub>CCE</sub>	V <sub>CC</sub> Erase Current	Flash	1,3	16	45	mA	F-V <sub>PP</sub> = V <sub>PP1</sub> Erase in Progress
				8	15	mA	F-V <sub>PP</sub> = V <sub>PP2</sub> (12 V) Erase in Progress
I <sub>CCES</sub>	V <sub>CC</sub> Erase Suspend Current	Flash	1,3,4	7	15	μA	F-CE# = V <sub>CC</sub> , Erase Suspend in Progress
I <sub>CCWS</sub>	V <sub>CC</sub> Program Suspend Current	0.25μm Flash	1,3,4	10	25	μA	F-CE# = V <sub>CC</sub> , Program Suspend in Progress
		0.13μm and 0.18μm Flash	1,3,4	7	15		
I <sub>PPD</sub>	F-V <sub>PP</sub> Deep Power-Down Current	Flash	1	0.2	5	μA	F-RP# = GND ± 0.2 V F-V <sub>PP</sub> ≤ V <sub>CC</sub>
I <sub>PPS</sub>	F-V <sub>PP</sub> Standby Current	Flash	1	0.2	5	μA	F-V <sub>PP</sub> ≤ V <sub>CC</sub>
I <sub>PPR</sub>	F-V <sub>PP</sub> Read Current	Flash	1	2	±15	μA	F-V <sub>PP</sub> ≤ V <sub>CC</sub>
			1,2	50	200	μA	F-V <sub>PP</sub> ≥ V <sub>CC</sub>
I <sub>PPW</sub>	F-V <sub>PP</sub> Program Current	Flash	1,2	0.05	0.1	mA	F-V <sub>PP</sub> = V <sub>PP1</sub> Program in Progress
				8	22	mA	F-V <sub>PP</sub> = V <sub>PP2</sub> (12 V) Program in Progress
I <sub>PPE</sub>	F-V <sub>PP</sub> Erase Current	Flash	1,2	0.05	0.1	ma	F-V <sub>PP</sub> = V <sub>PP1</sub> Erase in Progress
I <sub>PPES</sub>	F-V <sub>PP</sub> Erase Suspend Current	Flash	1,2	0.2	5	μA	F-V <sub>PP</sub> = V <sub>PP1</sub> Erase Suspend in Progress
				50	200	μA	F-V <sub>PP</sub> = V <sub>PP2</sub> (12 V) Erase Suspend in Progress
I <sub>PPWS</sub>	F-V <sub>PP</sub> Program Suspend Current	Flash	1,2	0.2	5	μA	F-V <sub>PP</sub> = V <sub>PP1</sub> Program Suspend in Progress
				50	200	μA	F-V <sub>PP</sub> = V <sub>PP2</sub> (12 V) Program Suspend in Progress

**NOTES:**

1. All currents are in RMS unless otherwise noted. Typical values at nominal F-V<sub>CC</sub>/S-V<sub>CC</sub>, T<sub>CASE</sub> = +25 °C.
2. Automatic Power Savings (APS) reduces I<sub>CCR</sub> to approximately standby levels in static operation (CMOS inputs).
3. Sampled, not 100% tested.
4. I<sub>CCES</sub> and I<sub>CCWS</sub> are specified with device de-selected. If device is read while in erase suspend, current draw is sum of I<sub>CCES</sub> and I<sub>CCR</sub>. If the device is read while in program suspend, current draw is the sum of I<sub>CCWS</sub> and I<sub>CCR</sub>.

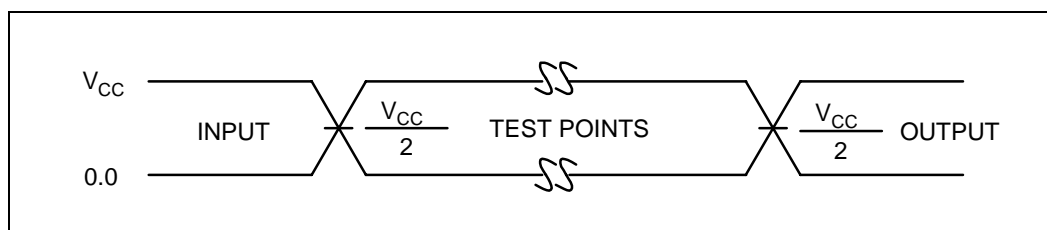
**Table 12. DC Characteristics**

Symbol	Parameter	Device	Note	2.7 V – 3.3 V		Units	Test Conditions
				Min	Max		
V <sub>IL</sub>	Input Low Voltage	Flash/ SRAM		-0.2	0.6	V	
V <sub>IH</sub>	Input High Voltage	Flash/ SRAM		2.3	V <sub>CC</sub> +0.2	V	
V <sub>OL</sub>	Output Low Voltage	Flash/ SRAM		-0.10	0.10	V	F-V <sub>CC</sub> /S-V <sub>CC</sub> = V <sub>CC</sub> Min I <sub>OL</sub> = 100 μA
V <sub>OH</sub>	Output High Voltage	Flash/ SRAM		V <sub>CC</sub> - 0.1		V	F-V <sub>CC</sub> /S-V <sub>CC</sub> = V <sub>CC</sub> Min I <sub>OH</sub> = -100 μA
V <sub>PPLK</sub>	F-V <sub>PP</sub> Lock-Out Voltage	Flash	1		1.0	V	Complete Write Protection
V <sub>PP1</sub>	F-V <sub>PP</sub> during Program / Erase	Flash	1	1.65	3.3	V	
V <sub>PP2</sub>	Operations		1,2	11.4	12.6		
V <sub>LKO</sub>	V <sub>CC</sub> Prog/Erase Lock Voltage	Flash		1.5		V	
V <sub>LKO2</sub>	V <sub>CCQ</sub> Prog/Erase Lock Voltage	Flash		1.2		V	

**NOTES:**

1. Erase and Program are inhibited when F-V<sub>pp</sub> < V<sub>PPLK</sub> and not guaranteed outside the valid F-V<sub>pp</sub> ranges of V<sub>PP1</sub> and V<sub>PP2</sub>.
2. Applying F-V<sub>pp</sub> = 11.4V–12.6V during program/erase can only be done for a maximum of 1000 cycles on the main blocks and 2500 cycles on the parameter blocks. F-V<sub>pp</sub> may be connected to 12 V for a total of 80 hours maximum. See Section 4.2.1 for details.

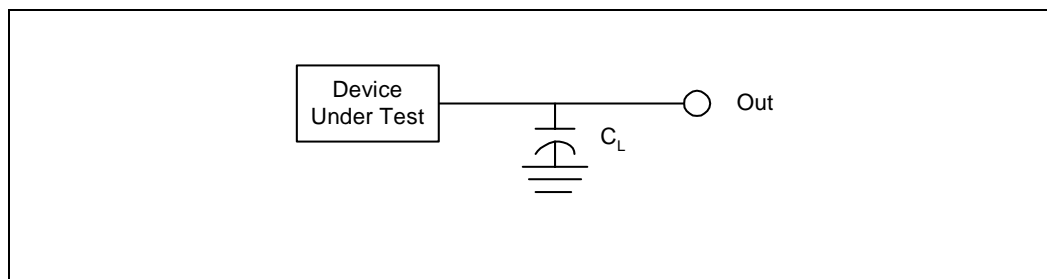
**Figure 4. Input/Output Reference Waveform**



**NOTE:** AC test inputs are driven at V<sub>CCQ</sub> for a logic “1” and 0.0V for a logic “0.” Input timing begins, and output timing ends, at V<sub>CCQ</sub>/2. Input rise and fall times (10%–90%) <10 ns. Worst case speed conditions are when V<sub>CCQ</sub> = V<sub>CCQ</sub>Min.

0645\_07

**Figure 5. Test Configuration**



**NOTE:** C<sub>L</sub> includes jig capacitance.

0666\_05



Flash Test Configuration Component Values Table

Test Configuration	C <sub>L</sub> (pF)
2.7 V–3.3 V Standard Test	50

## 5.5 Flash AC Characteristics.

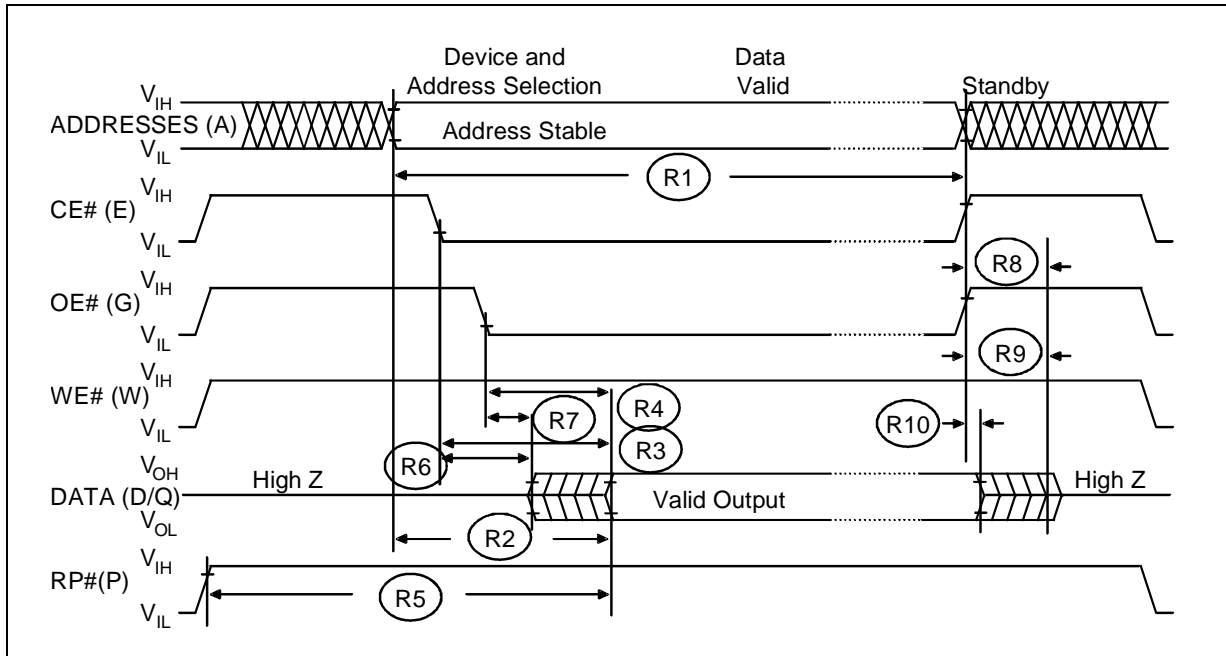
Table 13. Flash AC Characteristics—Read Operations

#	Sym	Parameter	Density	16-Mbit						32-Mbit				Unit
			Product	-70	-90	-110	-70	-90						
			Voltage Range	2.7 V - 3.3 V										
			Note	Min	Max	Min	Max	Min	Max	Min	Max	Min	Max	
R1	t <sub>AVAV</sub>	Read Cycle Time		70		90		110		70		90		ns
R2	t <sub>AVQV</sub>	Address to Output Delay			70		90		110		70		90	ns
R3	t <sub>ELQV</sub>	F-CE# to Output Delay	1		70		90		110		70		90	ns
R4	t <sub>GLQV</sub>	F-OE# to Output Delay	1		20		30		30		20		20	ns
R5	t <sub>PHQV</sub>	F-RP# to Output Delay			150		150		150		150		150	ns
R6	t <sub>ELQX</sub>	F-CE# to Output in Low Z	2	0		0		0		0		0		ns
R7	t <sub>GLQX</sub>	F-OE# to Output in Low Z	2	0		0		0		0		0		ns
R8	t <sub>EHQZ</sub>	F-CE# to Output in High Z	2		20		25		25		20		20	ns
R9	t <sub>GHQZ</sub>	F-OE# to Output in High Z	2		20		20		20		20		20	ns
R10	t <sub>OH</sub>	Output Hold from Address F-CE#, or F-OE# Change, Whichever Occurs First	2	0		0		0		0		0		ns

**NOTES:**

1. F-OE# may be delayed up to t<sub>ELQV</sub>–t<sub>GLQV</sub> after the falling edge of CE# without impact on t<sub>ELQV</sub>
2. Sampled, but not 100% tested.
3. See Figure 6, “AC Waveform: Flash Read Operations” on page 30.
4. See Figure 4, “Input/Output Reference Waveform” on page 28 for timing measurements and maximum allowable input slew rate.

Figure 6. AC Waveform: Flash Read Operations





## 5.6 Flash AC Characteristics—Write Operations

Table 14. Flash AC Characteristics—Write Operations

#	Sym	Parameter	Density	16-Mbit			32-Mbit		Unit
			Product	-70	-90	-110	-70	-90	
			Voltage Range	2.7 V - 3.3 V					
			Note	Min	Min	Min	Min	Min	
W1	$t_{PHWL}$ $t_{PHEL}$	F-RP# High Recovery to F-WE# (F-CE#) Going Low		150	150	150	150	150	ns
W2	$t_{ELWL}$ $t_{WLEL}$	F-CE# (F-WE#) Setup to F-WE# (F-CE#) Going Low		0	0	0	0	0	ns
W3	$t_{ELEH}$ $t_{WLWH}$	F-WE# (F-CE#) Pulse Width	1	45	60	70	45	60	ns
W4	$t_{DVWH}$ $t_{DVEH}$	Data Setup to F-WE# (F-CE#) Going High	2	40	50	60	40	40	ns
W5	$t_{AVWH}$ $t_{AVEH}$	Address Setup to F-WE# (F-CE#) Going High	2	50	60	70	50	60	ns
W6	$t_{WHEH}$ $t_{EHWH}$	F-CE# (F-WE#) Hold Time from F-WE# (F-CE#) High		0	0	0	0	0	ns
W7	$t_{WHDX}$ $t_{EHDX}$	Data Hold Time from F-WE# (F-CE#) High	2	0	0	0	0	0	ns
W8	$t_{WHAX}$ $t_{EHAX}$	Address Hold Time from F-WE# (F-CE#) High	2	0	0	0	0	0	ns
W9	$t_{WHWL}$ $t_{EHEL}$	F-WE# (F-CE#) Pulse Width High	1	25	30	30	25	30	ns
W10	$t_{VPWH}$ $t_{VPEH}$	F-V <sub>PP</sub> Setup to F-WE# (F-CE#) Going High	3	200	200	200	200	200	ns
W11	$t_{QVVL}$	F-V <sub>PP</sub> Hold from Valid SRD	3	0	0	0	0	0	ns

**NOTES:**

- Write pulse width ( $t_{WP}$ ) is defined from F-CE# or F-WE# going low (whichever goes low last) to F-CE# or F-WE# going high (whichever goes high first). Hence,  $t_{WP} = t_{WLWH} = t_{ELEH} = t_{WLEH} = t_{ELWH}$ . Similarly, write pulse width high ( $t_{WPH}$ ) is defined from F-CE# or F-WE# going high (whichever goes high first) to F-CE# or F-WE# going low (whichever goes low first). Hence,  $t_{WPH} = t_{WHWL} = t_{EHEL} = t_{WHEL} = t_{EHWL}$ .
- Refer to Table 5, “Flash Memory Command Definitions” on page 17 for valid A<sub>IN</sub> or D<sub>IN</sub>.
- Sampled, but not 100% tested.

See Figure 4, “Input/Output Reference Waveform” on page 28 for timing measurements and maximum allowable input slew rate.

See Figure 7, “AC Waveform: Flash Program and Erase Operations” on page 33.

## 5.7 Flash Erase and Program Timings<sup>(1)</sup>

Table 15. Flash Erase and Program Timings (Sheet 1 of 2)

Symbol	Parameter	F-V <sub>PP</sub>	1.65 V– 3.3 V		11.4 V– 12.6 V		Unit
		Note	Typ <sup>(1)</sup>	Max	Typ <sup>(1)</sup>	Max	
$t_{BWPB}$	4-KW Parameter Block Program Time (Word)	2, 3	0.10	0.30	0.03	0.12	s
$t_{BWMB}$	32-KW Main Block Program Time (Word)	2, 3	0.8	2.4	0.24	1	s
$t_{WHQV1} / t_{EHQV1}$	0.25 $\mu$ m Word Program Time	2, 3	22	200	8	185	$\mu$ s
	0.13 $\mu$ m and 0.18 $\mu$ m Word Program Time	2, 3	12	200	8	185	
$t_{WHQV2} / t_{EHQV2}$	4-KW Parameter Block Erase Time (Word)	2, 3	0.5	4	0.4	4	s



**Table 15. Flash Erase and Program Timings (Sheet 2 of 2)**

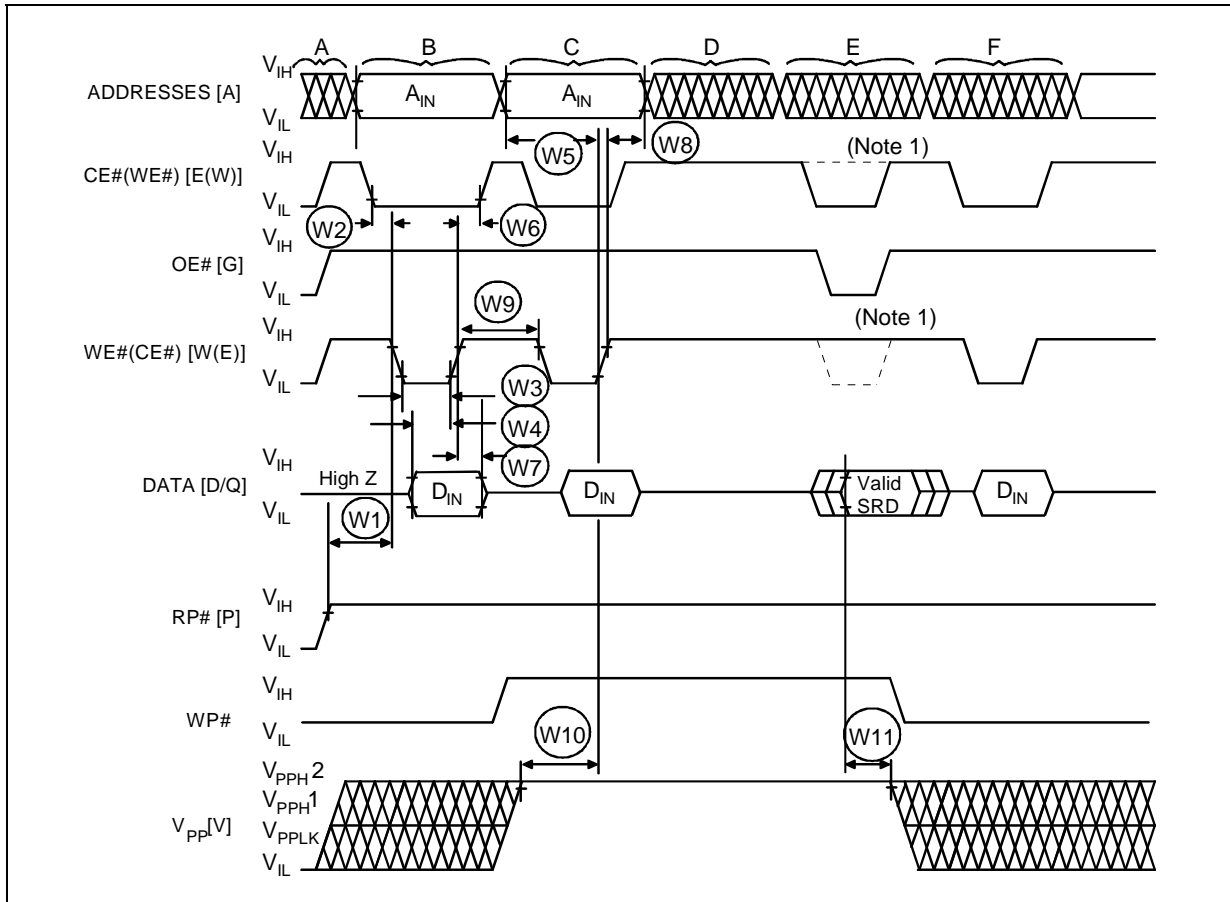
Symbol	Parameter	F-V <sub>PP</sub>	1.65 V– 3.3 V		11.4 V– 12.6 V		Unit
		Note	Typ <sup>(1)</sup>	Max	Typ <sup>(1)</sup>	Max	
t <sub>WHQV3</sub> / t <sub>EHQV3</sub>	32-KW Main Block Erase Time (Word)	2, 3	1	5	0.6	5	s
t <sub>WHRH1</sub> / t <sub>EHRH1</sub>	Program Suspend Latency	3	5	10	5	10	µs
t <sub>WHRH2</sub> / t <sub>EHRH2</sub>	Erase Suspend Latency	3	5	20	5	20	µs

**NOTES:**

1. Typical values measured at T<sub>CASE</sub> = +25 °C and nominal voltages.
2. Excludes external system-level overhead.
3. Sampled, but not 100% tested.



Figure 7. AC Waveform: Flash Program and Erase Operations



**NOTES:**

1. F-CE# must be toggled low when reading Status Register Data. F-WE# must be inactive (high) when reading Status Register Data.

- A. F-VCC Power-Up and Standby.
- B. Write Program or Erase Setup Command.
- C. Write Valid Address and Data (for Program) or Erase Confirm Command.
- D. Automated Program or Erase Delay.
- E. Read Status Register Data (SRD): reflects completed program/erase operation.
- F. Write Read Array Command.

## 5.8 Flash Reset Operations

Figure 8. AC Waveform: Reset Operation

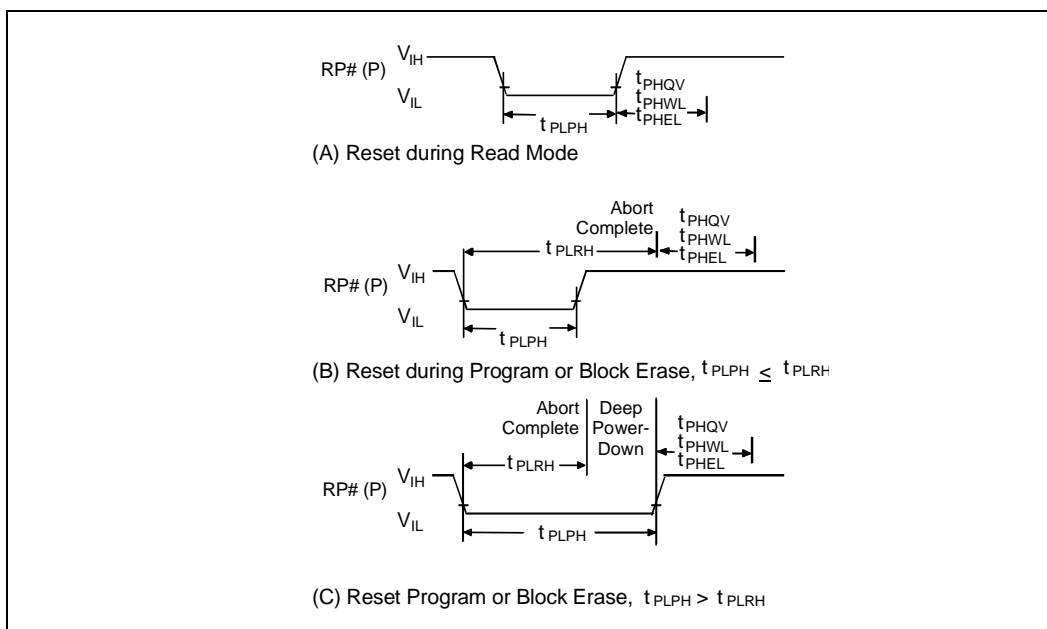


Table 16. Reset Specifications<sup>(1)</sup>

Symbol	Parameter	Note	F-V <sub>CC</sub> 2.7 V – 3.3 V		Unit
			Min	Max	
$t_{PLPH}$	F-RP# Low to Reset during Read (If F-RP# is tied to V <sub>CC</sub> , this specification is not applicable)	2,4	100		ns
$t_{PLRH1}$	F-RP# Low to Reset during Block Erase	3,4		22	μs
$t_{PLRH2}$	F-RP# Low to Reset during Program	3,4		12	μs

**NOTES:**

1. See Section 2.1.4, "Flash Reset" on page 13 for a full description of these conditions.
2. If  $t_{PLPH}$  is < 100 ns the device may still reset but this is not guaranteed.
3. If F-RP# is asserted while a block erase or word program operation is not executing, the reset will complete within 100 ns.
4. Sampled, but not 100% tested.

## 5.9 SRAM AC Characteristics—Read Operations

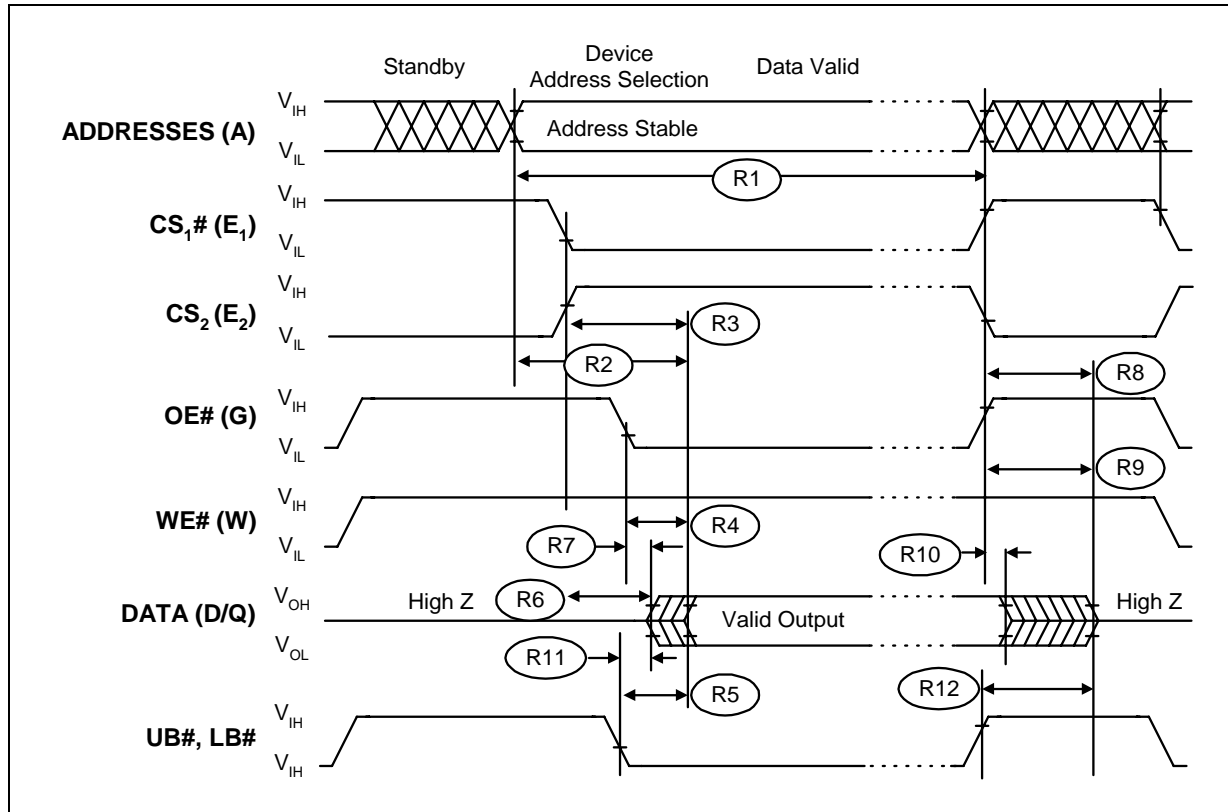
Table 17. SRAM AC Characteristics—Read Operations<sup>(1)</sup>

#	Sym	Parameter	Density		2/4/8-Mbit		Unit
			Voltage Range		2.7 V– 3.3 V		
				Note	Min	Max	
R1	$t_{RC}$	Read Cycle Time			70	–	ns
R2	$t_{AA}$	Address to Output Delay			–	70	ns
R3	$t_{CO1}, t_{CO2}$	S-CS1#, S-CS2 to Output Delay			–	70	ns
R4	$t_{OE}$	S-OE# to Output Delay			–	35	ns
R5	$t_{BA}$	S-UB#, LB# to Output Delay			–	70	ns
R6	$t_{LZ1}, t_{LZ2}$	S-CS1#, S-CS2 to Output in Low Z	2,3		5	–	ns
R7	$t_{OLZ}$	S-OE# to Output in Low Z	3		0	–	ns
R8	$t_{HZ1}, t_{HZ2}$	S-CS1#, S-CS2 to Output in High Z	2,3,4		0	25	ns
R9	$t_{OHZ}$	S-OE# to Output in High Z	3,4		0	25	ns
R10	$t_{OH}$	Output Hold from Address, S-CS1#, S-CS2, or S-OE# Change, Whichever Occurs First			0	–	ns
R11	$t_{BLZ}$	S-UB#, S-LB# to Output in Low Z	3		0	–	ns
R12	$t_{BHZ}$	S-UB#, S-LB# to Output in High Z	3		0	25	ns

**NOTE:**

1. See [Figure 9, “AC Waveform: SRAM Read Operations” on page 36](#).
2. At any given temperature and voltage condition,  $t_{HZ}$  (Max) is less than and  $t_{LZ}$  (Max) both for a given device and from device to device interconnection.
3. Sampled, but not 100% tested.
4. Timings of  $t_{HZ}$  and  $t_{OHZ}$  are defined as the time at which the outputs achieve the open circuit conditions and are not referenced to output voltage levels.

Figure 9. AC Waveform: SRAM Read Operations





## 5.10 SRAM AC Characteristics—Write Operations

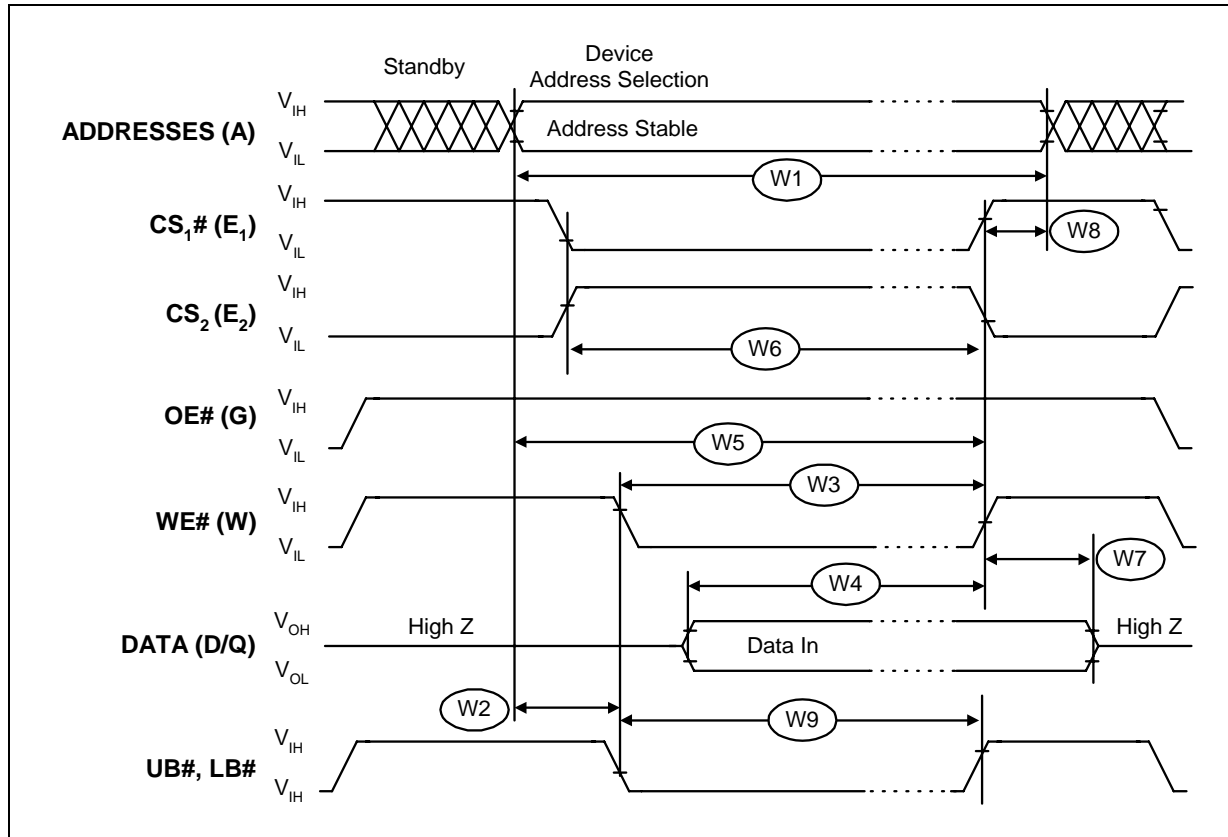
Table 18. SRAM AC Characteristics—Write Operations<sup>(1,2)</sup>

#	Sym	Parameter	Density		2/4/8-Mbit		Unit
			Volt		2.7 V – 3.3 V		
			Note	Min	Max		
W1	t <sub>WC</sub>	Write Cycle Time		70	–	ns	
W2	t <sub>AS</sub>	Address Setup to S-WE# (S-CS1#) and S-UB#, S-LB# Going Low	3	0	–	ns	
W3	t <sub>WP</sub>	S-WE# (S-CS1#) Pulse Width	4	55	–	ns	
W4	t <sub>DW</sub>	Data to Write Time Overlap		30	–	ns	
W5	t <sub>AW</sub>	Address Setup to S-WE# (S-CS1#) Going High		60	–	ns	
W6	t <sub>CW</sub>	S-CE# (S-WE#) Setup to S-WE# (S-CS1#) Going High		60	–	ns	
W7	t <sub>DH</sub>	Data Hold Time from S-WE# (S-CS1#) High		0	–	ns	
W8	t <sub>WR</sub>	Write Recovery	5	0	–	ns	
W9	t <sub>BW</sub>	S-UB#, S-LB# Setup to S-WE# (S-CS1#) Going High		60	–	ns	

**NOTES:**

1. See Figure 10, “AC Waveform: SRAM Write Operations” on page 38.
2. A write occurs during the overlap (t<sub>WP</sub>) of low S-CS1# and low S-WE#. A write begins when S-CS1# goes low and S-WE# goes low with asserting S-UB# or S-LB# for single byte operation or simultaneously asserting S-UB# and S-LB# for double byte operation. A write ends at the earliest transition when S-CS1# goes high and S-WE# goes high. The t<sub>WP</sub> is measured from the beginning of write to the end of write.
3. t<sub>AS</sub> is measured from the address valid to the beginning of write.
4. t<sub>WP</sub> is measured from S-CS1# going low to end of write.
5. t<sub>WR</sub> is measured from the end of write to the address change. t<sub>WR</sub> applied in case a write ends as S-CS1# or S-WE# going high.

Figure 10. AC Waveform: SRAM Write Operations



## 5.11 SRAM Data Retention Characteristics—Extended Temperature

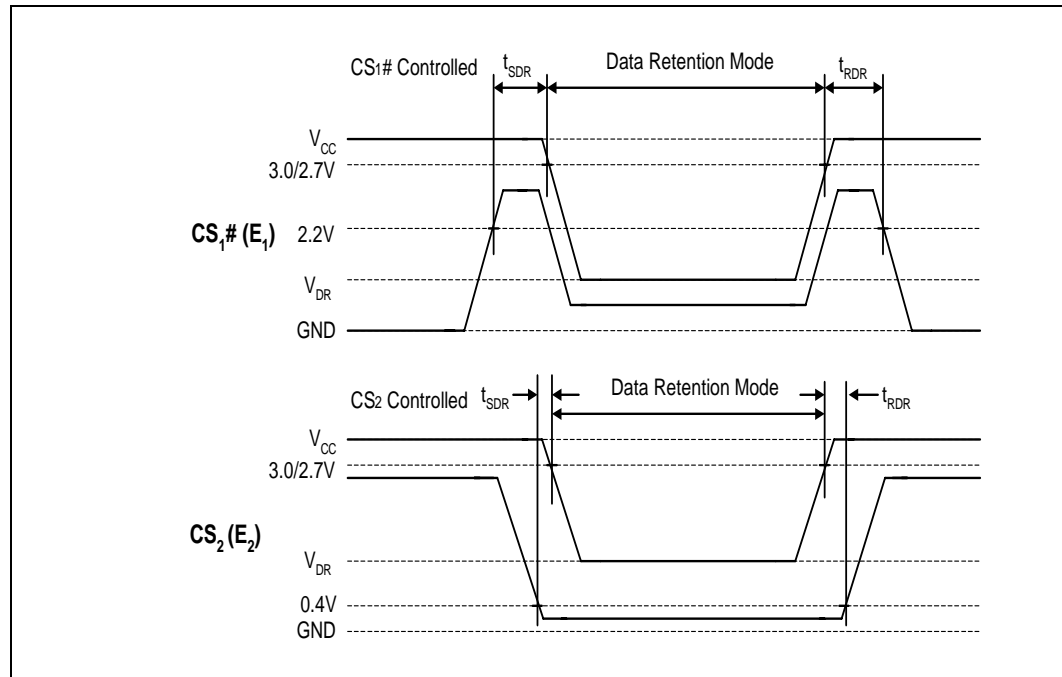
Table 19. SRAM Data Retention Characteristics<sup>(1)</sup>—Extended Temperature

Sym	Parameter	Note	Min	Typ	Max	Unit	Test Conditions
$V_{DR}$	S- $V_{CC}$ for Data Retention		1.5	–	3.3	V	$CS_{1\#} \geq V_{CC} - 0.2$ V
$I_{DR}$	Deep Retention Current - 8-Mbit	2	–	–	6	$\mu$ A	S- $V_{CC} = 1.5$ V $CS_{1\#} \geq V_{CC} - 0.2$ V
	Deep Retention Current - 4-Mbit		–	–	5	$\mu$ A	
	Deep Retention Current - 2-Mbit		–	–	4	$\mu$ A	
$t_{SDR}$	Data Retention Set-up Time		0	–	–	ns	See Data Retention Waveform
$t_{RDR}$	Recovery Time		$t_{RC}$	–	–	ns	

**NOTES:**

1. Typical values at nominal S- $V_{CC}$ ,  $T_{CASE} = +25$  °C.
2. S- $CS_{1\#} \geq V_{CC} - 0.2$  V, S- $CS_{2\#} \geq V_{CC} - 0.2$  V (S- $CS_{1\#}$  controlled) or S- $CS_{2\#} \leq 0.2$  V (S- $CS_{2\#}$  controlled).

Figure 11. SRAM Data Retention Waveform





## 6.0 Migration Guide Information

---

Typically, it is important to discuss footprint migration compatibility between a new product and existing products. In this specific case, the Stacked-CSP allows the system designer to remove two separate memory footprints for individual flash and SRAM and replace them with a single footprint, thus resulting in an overall reduction in board space required. This implies that a new printed circuit board would be used to take advantage of this feature.

Since the flash in Stacked-CSP shares the same features as the Advanced+ Boot Block Features, conversions from the Advanced Boot Block are described in *AP-658 Designing for Upgrade to the Advanced+ Boot Block Flash Memory*, order number 292216.

Please contact your local Intel representation for detailed information about specific Flash + SRAM system migrations.



## 7.0 System Design Considerations

---

This section contains information that would have been contained in a product design guide in earlier generations. In an effort to simplify the amount of documentation, relevant system design considerations have been combined into this document.

### 7.1 Background

The Intel Advanced+ Boot Block Stacked chip scale package combines the features of the Advanced+ Boot Block flash memory architecture with a low-power SRAM to achieve an overall reduction in system board space. This enables applications to integrate security with simple software and hardware configurations, while also combining the system SRAM and flash into one common footprint. This section discusses how to take full advantage of the 3 Volt Advanced+ Boot Block Stacked Chip Scale Package.

#### 7.1.1 Flash + SRAM Footprint Integration

The Stacked Chip Scale Package memory solution can be used to replace a subset of the memory subsystem within a design. Where a previous design may have used two separate footprints for SRAM and Flash, you can now replace with the industry-standard I-ballout of the Stacked-CSP device. This allows for an overall reduction in board space, which allows the design to integrate both the flash and the SRAM into one component.

#### 7.1.2 Advanced+ Boot Block Flash Memory Features

Advanced+ Boot Block adds the following new features to Intel Advanced Boot Block architecture:

- Instant, individual block locking provides software/hardware controlled, independent locking/unlocking of any block with zero latency to protect code and data.
- A 128-bit Protection Register enables system security implementations.
- Improved 12 V production programming simplifies the system configuration required to implement 12 V fast programming.
- Common Flash Interface (CFI) provides component information on the chip to allow software-independent device upgrades.

For more information on specific advantages of the Advanced+ Boot Block Flash Memory, please see *AP-658 Designing with the Advanced+ Boot Block Flash Memory Architecture*.

### 7.2 Flash Control Considerations

The flash device is protected against accidental block erasure or programming during power transitions. Power supply sequencing is not required, since the device is indifferent as to which power supply, F-VPP or F-VCC, powers-up first. Example flash power supply configurations are shown in [Figure 12, “Example Power Supply Configurations” on page 42](#).

### 7.2.1 F-RP# Connected to System Reset

The use of F-RP# during system reset is important with automated program/erase devices since the system expects to read from the flash memory when it comes out of reset. If a CPU reset occurs without a flash memory reset, proper CPU initialization will not occur because the flash memory may be providing status information instead of array data. Intel recommends connecting F-RP# to the system CPU RESET# signal to allow proper CPU/flash initialization following system reset.

System designers must guard against spurious writes when F-V<sub>CC</sub> voltages are above V<sub>LKO</sub>. Since both F-WE# and F-CE# must be low for a command write, driving either signal to V<sub>IH</sub> will inhibit writes to the device. The CUI architecture provides additional protection since alteration of memory contents can only occur after successful completion of the two-step command sequences. The device is also disabled until F-RP# is brought to V<sub>IH</sub>, regardless of the state of its control inputs.

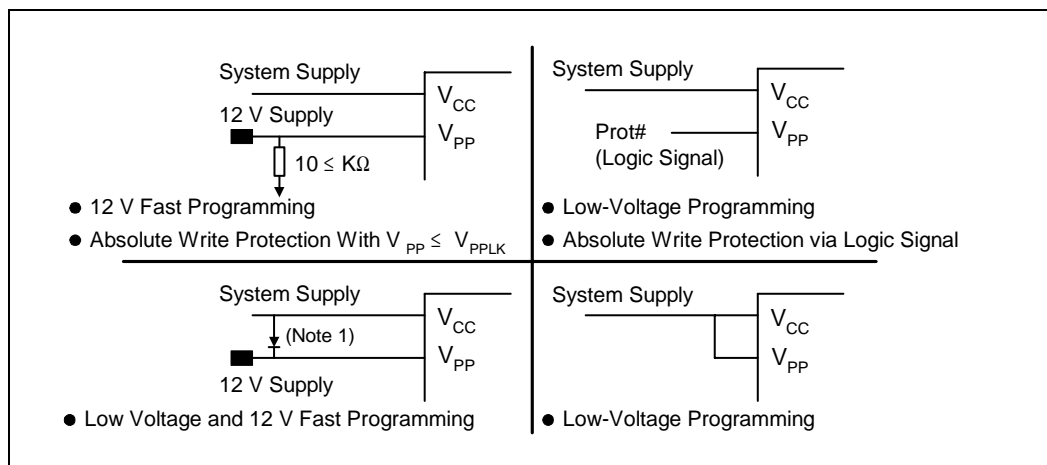
By holding the device in reset (F-RP# connected to system PowerGood) during power-up/down, invalid bus conditions during power-up can be masked, providing yet another level of memory protection.

### 7.2.2 F-V<sub>CC</sub>, F-V<sub>PP</sub> and F-RP# Transition

The CUI latches commands as issued by system software and is not altered by F-V<sub>PP</sub> or F-CE# transitions or WSM actions. Its default state upon power-up, after exit from reset mode or after F-V<sub>CC</sub> transitions above V<sub>LKO</sub> (Lockout voltage), is read array mode.

After any program or block erase operation is complete (even after F-V<sub>PP</sub> transitions down to V<sub>PPLK</sub>), the CUI must be reset to read array mode via the Read Array command if access to the flash memory array is desired.

Figure 12. Example Power Supply Configurations



NOTE: 1. A resistor can be used if the F-V<sub>CC</sub> supply can sink adequate current based on resistor value.

## 7.3 Noise Reduction

Stacked-CSP memory's power switching characteristics require careful device decoupling. System designers should consider three supply current issues for both the flash and SRAM:

1. Standby current levels ( $I_{CCS}$ )
2. Read current levels ( $I_{CCR}$ )
3. Transient peaks produced by falling and rising edges of F-CE#, S-CS1#, and S-CS2.

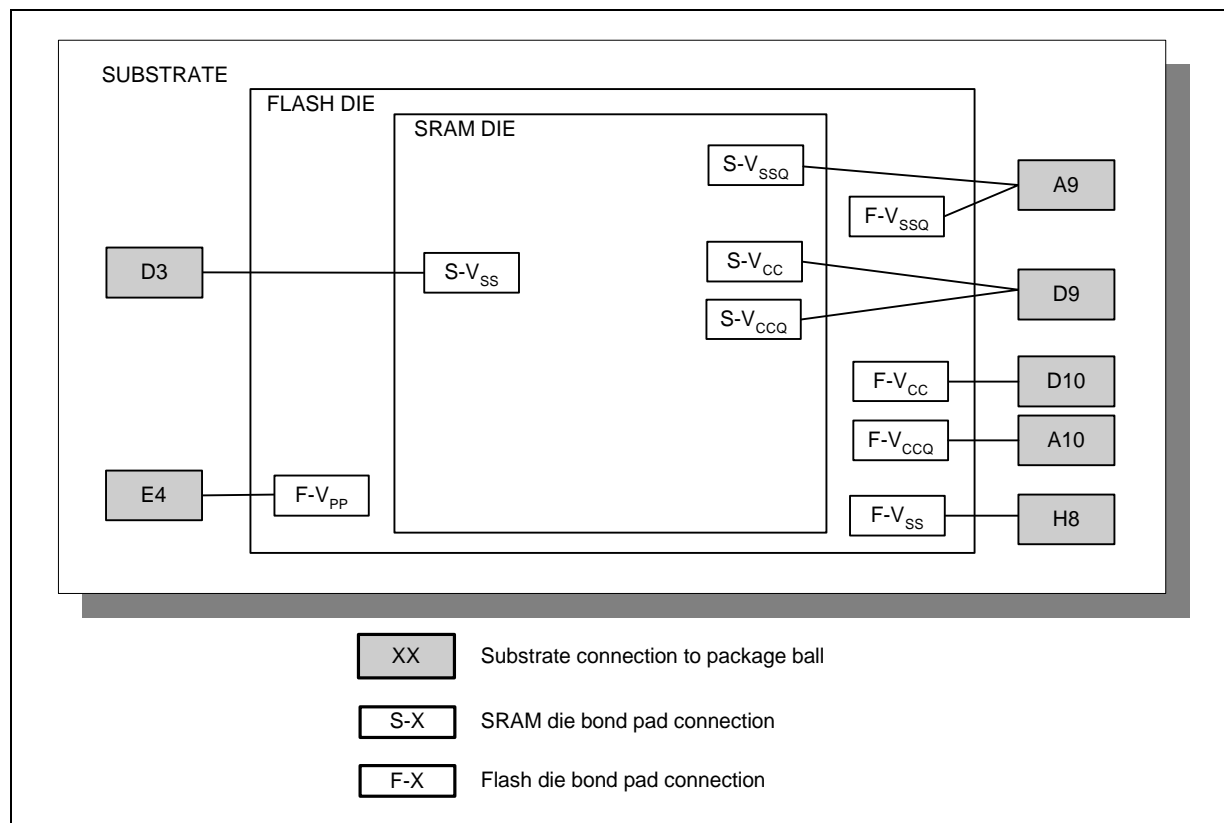
Transient current magnitudes depend on the device outputs' capacitive and inductive loading. Two-line control and proper decoupling capacitor selection will suppress these transient voltage peaks. Each device should have a capacitors between individual power (F-VCC, F-VCCQ, F-VPP, S-VCC) and ground (GND) signals. High-frequency, inherently low-inductance capacitors should be placed as close as possible to the package leads.

Noise issues within a system can cause devices to operate erratically if it is not adequately filtered. In order to avoid any noise interaction issues within a system, it is recommended that the design contain the appropriate number of decoupling capacitors in the system. Noise issues can also be reduced if leads to the device are kept very short, in order to reduce inductance.

Decoupling capacitors between  $V_{CC}$  and  $V_{SS}$  reduce voltage spikes by supplying the extra current needed during switching. Placing these capacitors as close to the device as possible reduces line inductance. The capacitors should be low inductance capacitors; surface mount capacitors typically exhibit lower inductance.

It is highly recommended that systems use a 0.1  $\mu\text{f}$  capacitor for each of the D9, D10, A10 and E4 grid ballout locations (see [Figure 1, "66-Ball Stacked Chip Scale Package"](#) on page 8 for ballout). These capacitors are necessary to avoid undesired conditions created by excess noise. Smaller capacitors can be used to decouple higher frequencies.

Figure 13. Typical Flash + SRAM Substrate Power and Ground Connections



**NOTES:**

1. Substrate connections refer to ballout locations shown in [Figure 1, "66-Ball Stacked Chip Scale Package"](#) on page 8.
2. 0.1µf capacitors should be used with D9, D10, A10 and E4.
3. Some SRAM devices do not have a S-VSSQ; in this case, this pad is a S-VSS.
4. Some SRAM devices do not have a S-VSSQ; in this case, this pad is a VCC.

## 7.4 Simultaneous Operation

The term simultaneous operation is used to describe the ability to read or write to the SRAM while also programming or erasing flash. In addition, F-CE#, S-CS1# and S-CS2 should not be enabled at the same time. (See [Table 2, "3 Volt Intel® Advanced+ Boot Block Stacked-CSP Ball Descriptions"](#) on page 9 for a summary of recommended operating modes.) Simultaneous operation of the can be summarized by the following:

- SRAM read/write are during a Flash Program or Erase Operation are allowed.
- Simultaneous Bus Operations between the Flash and SRAM are **not** allowed (because of bus contention).

### 7.4.1 SRAM Operation during Flash “Busy”

This functionality provides the ability to use both the flash and the SRAM “at the same time” within a system, similar to the operation of two devices with separate footprints. This operation can be achieved by following the appropriate timing constraints within a system.

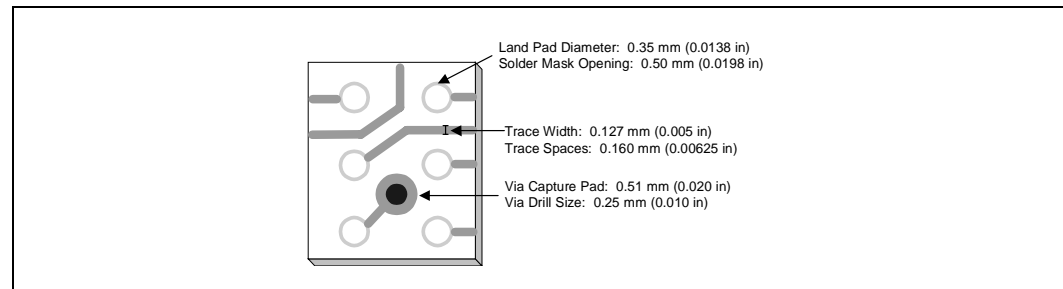
### 7.4.2 Simultaneous Bus Operations

Operations that require both the SRAM and Flash to be in active mode are disallowed. An example of these cases would include simultaneous reads on both the flash and SRAM, which would result in contention for the data bus. Finally, a read of one device while attempting to write to the other (similar to the conditions of direct memory access (DMA) operation) are also not within the recommended operating conditions. Basically, only one memory can drive the outputs out the device at one given point in time.

## 7.5 Printed Circuit Board Notes

The Intel Stacked-CSP will save significant space on your PCB by combining two chips into one BGA style package. Intel Stacked-CSP has a 0.8 mm pitch that can be routed on your Printed Circuit Board with conventional design rules. Trace widths of 0.127 mm (0.005 inches) are typical. Unused balls in the center of the package are not populated to further increase the routing options. Standard surface mount process and equipment can be used for the Intel Stacked-CSP.

Figure 14. Standard PCB Design Rules Can be Used with Stacked-CSP Device



NOTE: Top View

## 7.6 System Design Notes Summary

The Advanced+ Boot Block Stacked-CSP allows higher levels of memory component integration. Different power supply configurations can be used within the system to achieve different objectives. At least three different 0.1 µf capacitors should be used to decouple the devices within a system. SRAM reads or writes during a flash program or erase are supported operations. Standard printed circuit board technology can be used.

## Appendix A Program/Erase Flowcharts

Figure 15. Automated Word Programming Flowchart

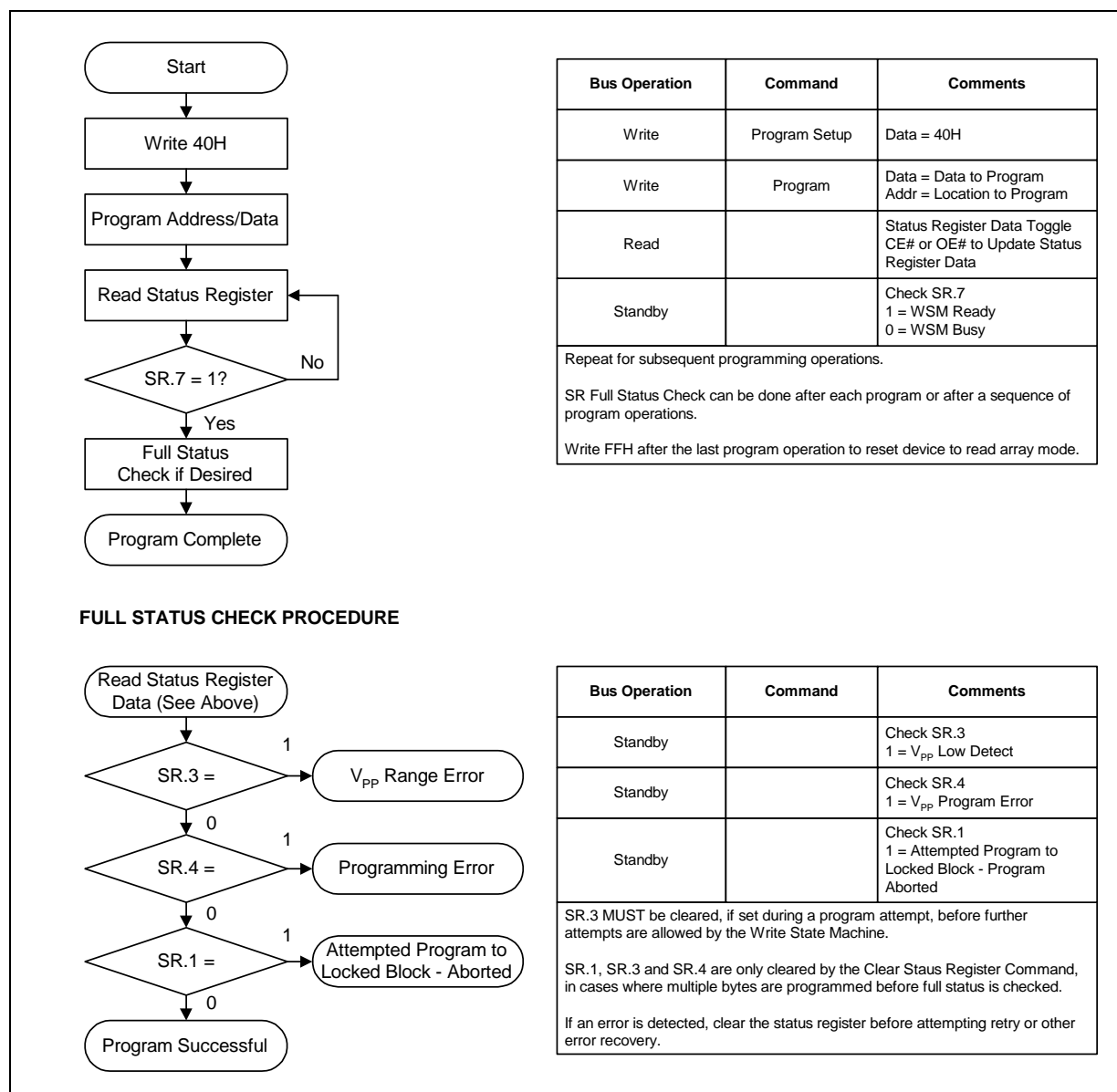
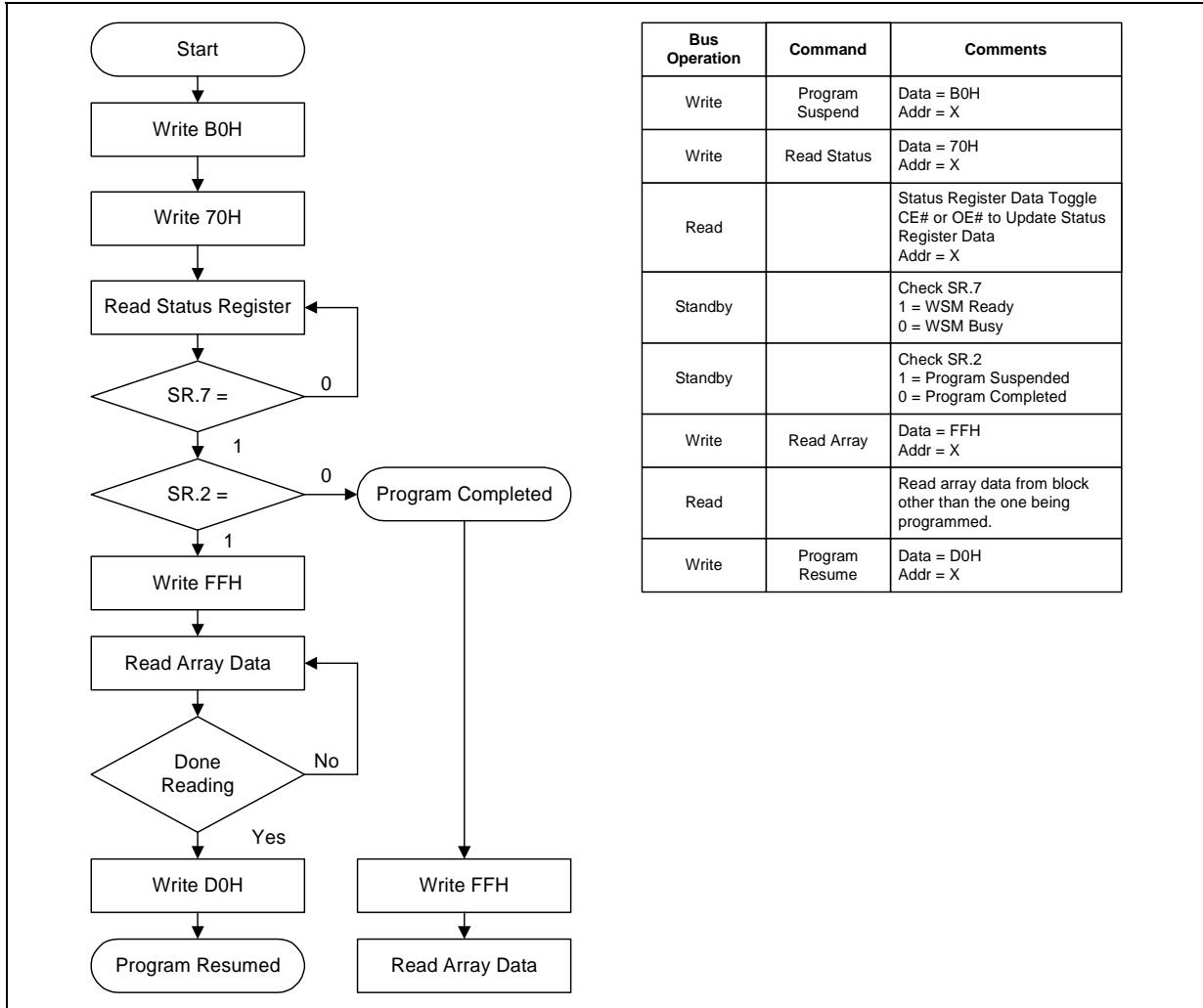
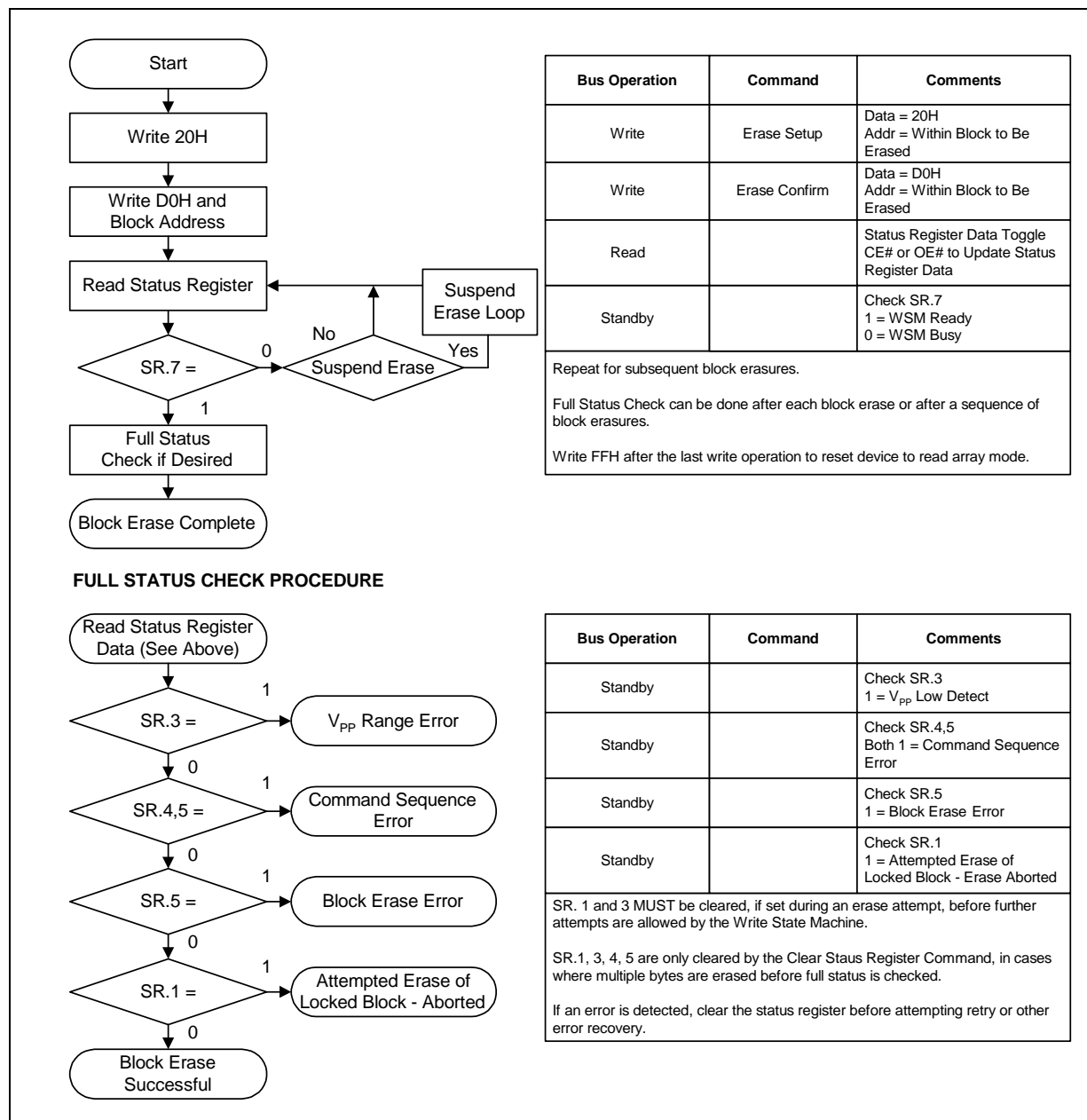


Figure 16. Program Suspend/Resume Flowchart



0645\_13

Figure 17. Automated Block Erase Flowchart



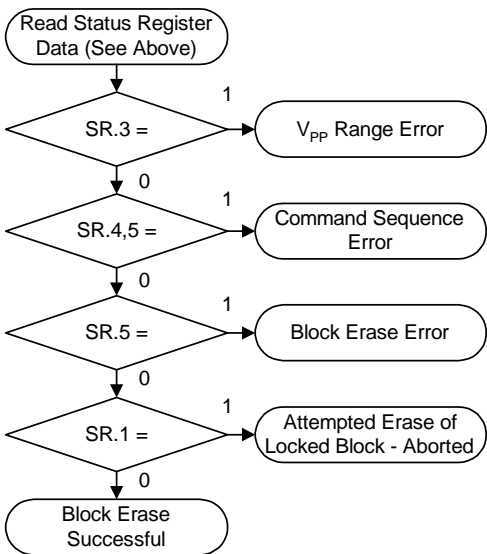
Bus Operation	Command	Comments
Write	Erase Setup	Data = 20H Addr = Within Block to Be Erased
Write	Erase Confirm	Data = D0H Addr = Within Block to Be Erased
Read		Status Register Data Toggle CE# or OE# to Update Status Register Data
Standby		Check SR.7 1 = WSM Ready 0 = WSM Busy

Repeat for subsequent block erasures.

Full Status Check can be done after each block erase or after a sequence of block erasures.

Write FFH after the last write operation to reset device to read array mode.

**FULL STATUS CHECK PROCEDURE**



Bus Operation	Command	Comments
Standby		Check SR.3 1 = V <sub>pp</sub> Low Detect
Standby		Check SR.4,5 Both 1 = Command Sequence Error
Standby		Check SR.5 1 = Block Erase Error
Standby		Check SR.1 1 = Attempted Erase of Locked Block - Erase Aborted

SR. 1 and 3 MUST be cleared, if set during an erase attempt, before further attempts are allowed by the Write State Machine.

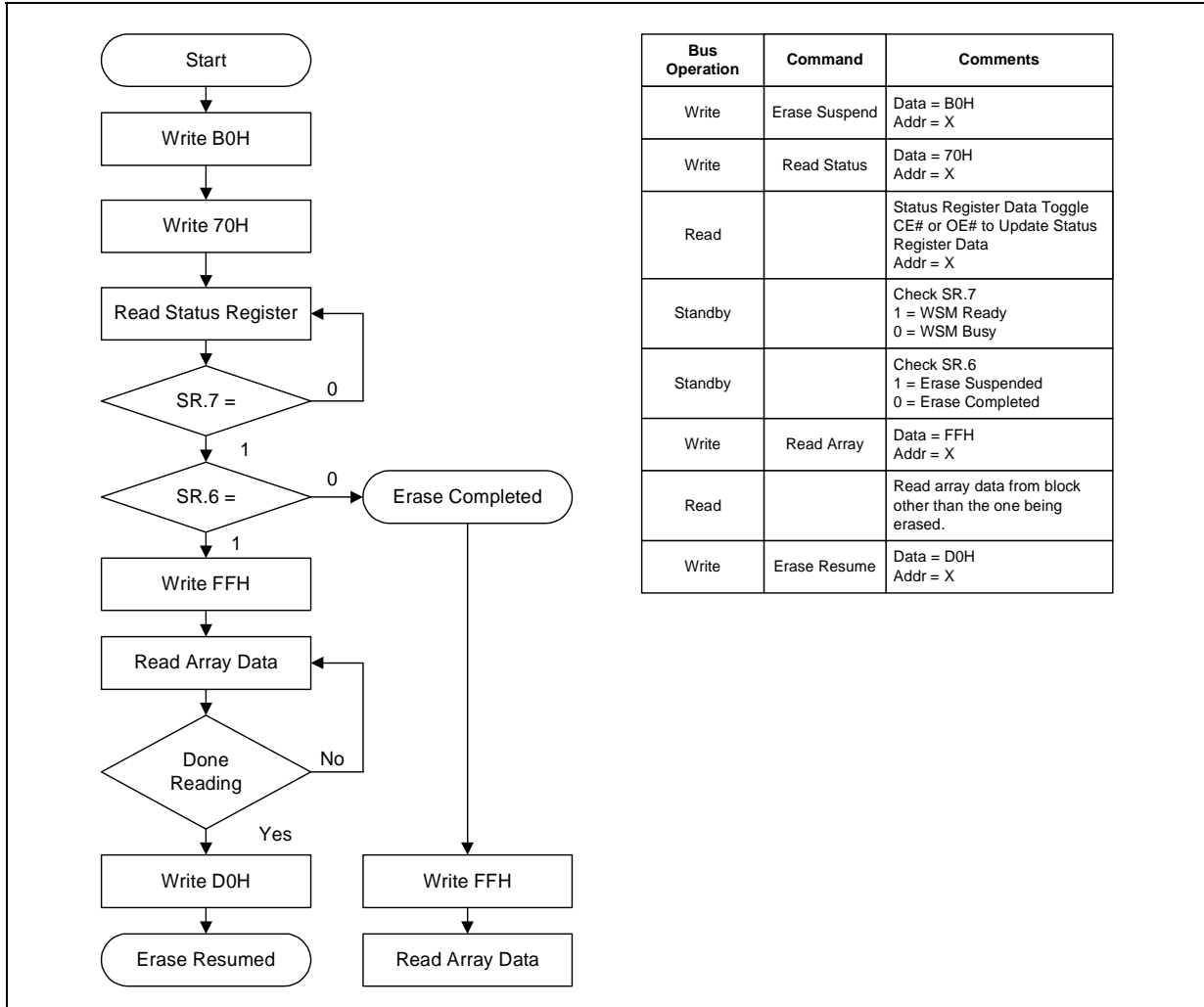
SR.1, 3, 4, 5 are only cleared by the Clear Status Register Command, in cases where multiple bytes are erased before full status is checked.

If an error is detected, clear the status register before attempting retry or other error recovery.

0645\_14

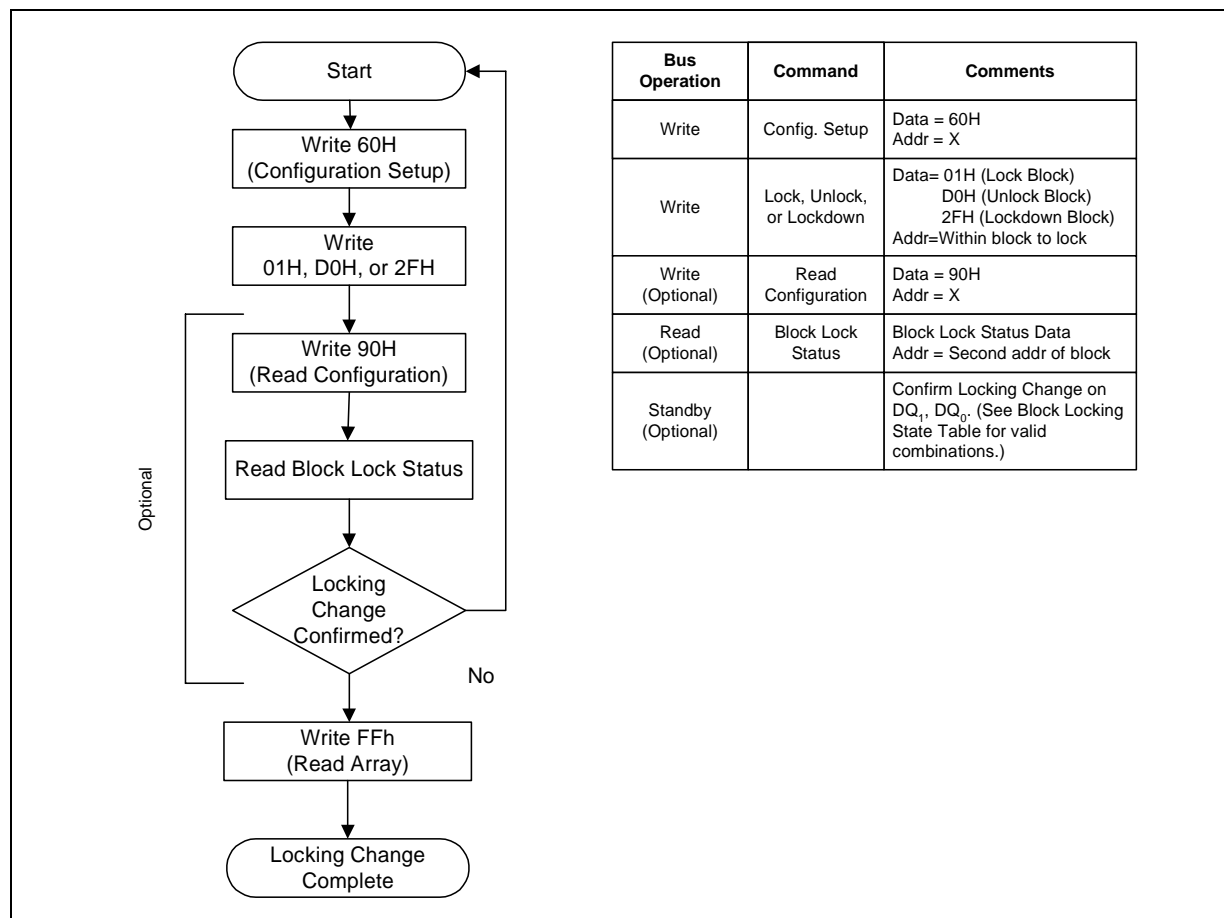


Figure 18. Erase Suspend/Resume Flowchart



0645\_15

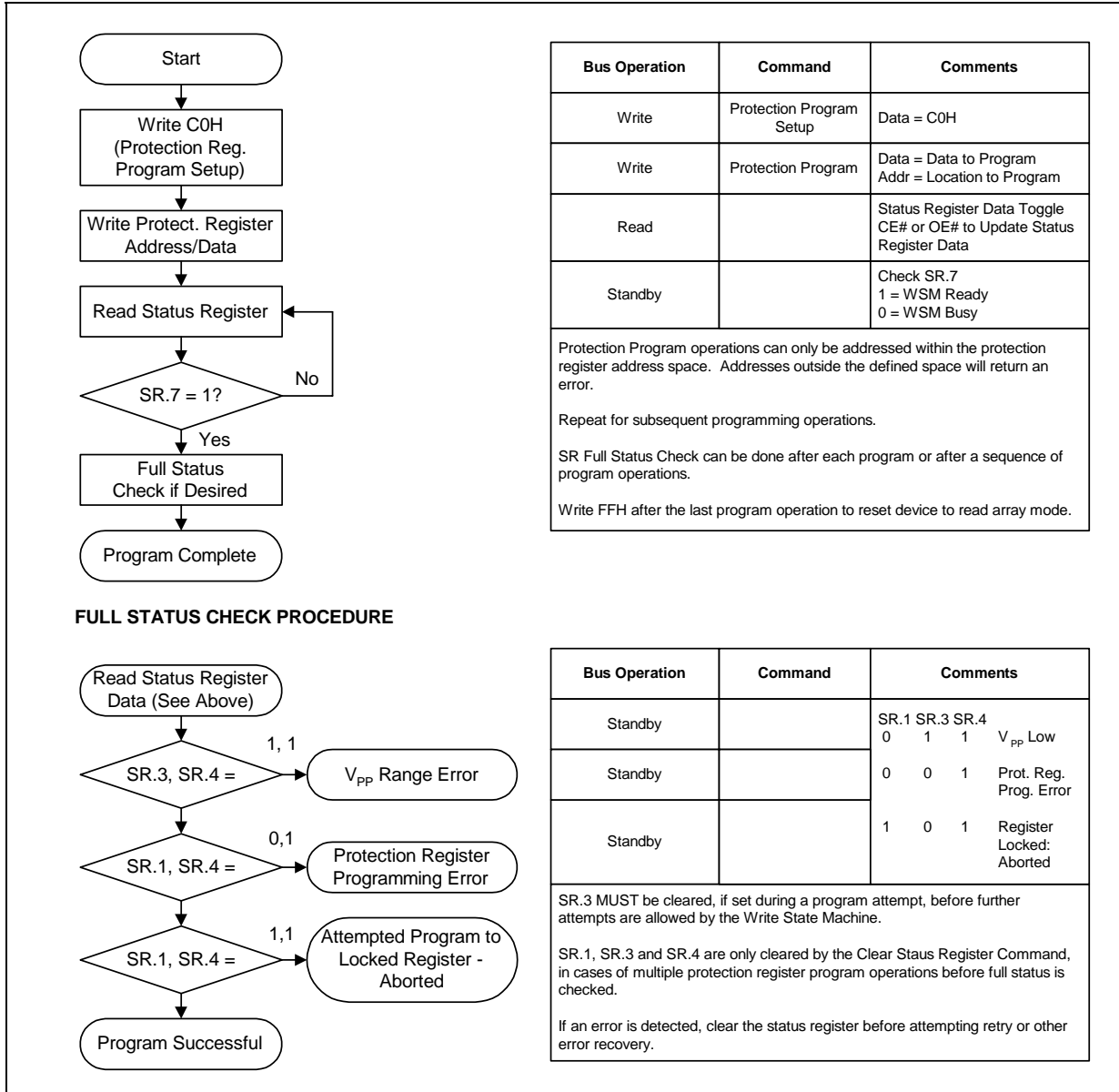
Figure 19. Locking Operations Flowchart



Bus Operation	Command	Comments
Write	Config. Setup	Data = 60H Addr = X
Write	Lock, Unlock, or Lockdown	Data= 01H (Lock Block) D0H (Unlock Block) 2FH (Lockdown Block) Addr=Within block to lock
Write (Optional)	Read Configuration	Data = 90H Addr = X
Read (Optional)	Block Lock Status	Block Lock Status Data Addr = Second addr of block
Standby (Optional)		Confirm Locking Change on DQ <sub>0</sub> , DQ <sub>1</sub> . (See Block Locking State Table for valid combinations.)

0645\_16

Figure 20. Protection Register Programming Flowchart



0645\_17

## Appendix B CFI Query Structure

This appendix defines the data structure or “database” returned by the Common Flash Interface (CFI) Query command. System software should parse this structure to gain critical information such as block size, density, x8/x16, and electrical specifications. Once this information has been obtained, the software will know which command sets to use to enable flash writes, block erases, and otherwise control the flash component. The Query is part of an overall specification for multiple command set and control interface descriptions called Common Flash Interface, or CFI.

### B.1 Query Structure Output

The Query “database” allows system software to gain information for controlling the flash component. This section describes the device’s CFI-compliant interface that allows the host system to access Query data.

Query data are always presented on the lowest-order data outputs (DQ<sub>0-7</sub>) only. The numerical offset value is the address relative to the maximum bus width supported by the device. On this family of devices, the Query table device starting address is a 10h, which is a word address for x16 devices.

For a word-wide (x16) device, the first two bytes of the Query structure, “Q” and “R” in ASCII, appear on the low byte at word addresses 10h and 11h. This CFI-compliant device outputs 00h data on upper bytes. Thus, the device outputs ASCII “Q” in the low byte (DQ<sub>0-7</sub>) and 00h in the high byte (DQ<sub>8-15</sub>).

At Query addresses containing two or more bytes of information, the least significant data byte is presented at the lower address, and the most significant data byte is presented at the higher address.

In all of the following tables, addresses and data are represented in hexadecimal notation, so the “h” suffix has been dropped. In addition, since the upper byte of word-wide devices is always “00h,” the leading “00” has been dropped from the table notation and only the lower byte value is shown. Any x16 device outputs can be assumed to have 00h on the upper byte in this mode.

**Table 20. Summary of Query Structure Output as a Function of Device and Mode**

Device	Hex Offset	Code	ASCII Value
Device Address	10:	51	“Q”
	11:	52	“R”
	12:	59	“Y”



**Table 21. Example of Query Structure Output of x16 and x8 Devices**

Word Addressing			Byte Addressing		
Offset	Hex Code	Value	Offset	Hex Code	Value
A <sub>15</sub> -A <sub>0</sub>	D <sub>15</sub> -D <sub>0</sub>		A <sub>7</sub> -A <sub>0</sub>	D <sub>7</sub> -D <sub>0</sub>	
0010h	0051	“Q”	10h	51	“Q”
0011h	0052	“R”	11h	52	“R”
0012h	0059	“Y”	12h	59	“Y”
0013h	P_IDLO	PrVendor	13h	P_IDLO	PrVendor
0014h	P_IDHI	ID #	14h	P_IDLO	ID #
0015h	PLO	PrVendor	15h	P_IDHI	ID #
0016h	PHI	TblAdr	16h	...	...
0017h	A_IDLO	AltVendor	17h		
0018h	A_IDHI	ID #	18h		
...	...	...	...		

## B.2 Query Structure Overview

The Query command causes the flash component to display the Common Flash Interface (CFI) Query structure or “database.” The structure sub-sections and address locations are summarized below.

**Table 22. Query Structure**

Offset	Sub-Section Name	Description	Notes
00h		Manufacturer Code	1
01h		Device Code	1
(BA+2)h	Block Status Register	Block-specific information	1,2
04-0Fh	Reserved	Reserved for vendor-specific information	1
10h	CFI Query Identification String	Command set ID and vendor data offset	1
1Bh	System Interface Information	Device timing & voltage information	1
27h	Device Geometry Definition	Flash device layout	1
P	Primary Intel-Specific Extended Query Table	Vendor-defined additional information specific to the Primary Vendor Algorithm	1,3

**NOTES:**

1. Refer to the Query Structure Output section and offset 28h for the detailed definition of offset address as a function of device bus width and mode.
2. BA = The beginning location of a Block Address (e.g., 08000h is the beginning location of block 1 when the block size is 32 Kword).
3. Offset 15 defines “P” which points to the Primary Intel-specific Extended Query Table.

## B.3 Block Lock Status Register

The Block Status Register indicates whether an erase operation completed successfully or whether a given block is locked or can be accessed for flash program/erase operations.

Block Erase Status (BSR.1) allows system software to determine the success of the last block erase operation. BSR.1 can be used just after power-up to verify that the  $V_{CC}$  supply was not accidentally removed during an erase operation. This bit is only reset by issuing another erase operation to the block. The Block Status Register is accessed from word address 02h within each block.

**Table 23. Block Status Register**

Offset	Length	Description	Address	Value	Notes
(BA+2)h	1	Block Lock Status Register	BA+2:	--00 or --01	1
		BSR.0 Block Lock Status 0 = Unlocked 1 = Locked	BA+2:	(bit 0): 0 or 1	
		BSR.1 Block Lock-Down Status 0 = Not locked down 1 = Locked down	BA+2:	(bit 1): 0 or 1	
		BSR 2–7: <i>Reserved for future use</i>	BA+2:	(bit 2–7): 0	

**NOTE:** 1. BA = The beginning location of a Block Address (i.e., 008000h is the beginning location of block 1 in word mode.)

## B.4 CFI Query Identification String

The Identification String provides verification that the component supports the Common Flash Interface specification. It also indicates the specification version and supported vendor-specified command set(s).

**Table 24. CFI Identification**

Offset	Length	Description	Addr.	Hex Code	Value
10h	3	Query-unique ASCII string "QRY"	10: 11: 12:	--51 --52 --59	"Q" "R" "Y"
13h	2	Primary vendor command set and control interface ID code. 16-bit ID code for vendor-specified algorithms	13: 14:	--03 --00	
15h	2	Extended Query Table primary algorithm address	15: 16:	--35 --00	
17h	2	Alternate vendor command set and control interface ID code 0000h means no second vendor-specified algorithm exists	17: 18:	--00 --00	
19h	2	Secondary algorithm Extended Query Table address. 0000h means none exists	19: 1A:	--00 --00	



## B.5 System Interface Information

Table 25. System Interface Information

Offset	Length	Description	Addr.	Hex Code	Value
1Bh	1	V <sub>CC</sub> logic supply minimum program/erase voltage bits 0–3 BCD 100 mV bits 4–7 BCD volts	1B:	--27	2.7 V
1Ch	1	V <sub>CC</sub> logic supply maximum program/erase voltage bits 0–3 BCD 100 mV bits 4–7 BCD volts	1C:	--36	3.3 V
1Dh	1	V <sub>PP</sub> [programming] supply minimum program/erase voltage bits 0–3 BCD 100 mV bits 4–7 HEX volts	1D:	--B4	11.4 V
1Eh	1	V <sub>PP</sub> [programming] supply maximum program/erase voltage bits 0–3 BCD 100 mV bits 4–7 HEX volts	1E:	--C6	12.6 V
1Fh	1	"n" such that typical single word program time-out = 2 <sup>n</sup> μs	1F:	--05	32 μs
1Bh	1	V <sub>CC</sub> logic supply minimum program/erase voltage bits 0–3 BCD 100 mV bits 4–7 BCD volts	1B:	--27	2.7 V
1Ch	1	V <sub>CC</sub> logic supply maximum program/erase voltage bits 0–3 BCD 100 mV bits 4–7 BCD volts	1C:	--36	3.3 V
1Dh	1	V <sub>PP</sub> [programming] supply minimum program/erase voltage bits 0–3 BCD 100 mV bits 4–7 HEX volts	1D:	--B4	11.4 V
1Eh	1	V <sub>PP</sub> [programming] supply maximum program/erase voltage bits 0–3 BCD 100 mV bits 4–7 HEX volts	1E:	--C6	12.6 V
1Fh	1	"n" such that typical single word program time-out = 2 <sup>n</sup> μs	1F:	--05	32 μs
1Bh	1	V <sub>CC</sub> logic supply minimum program/erase voltage bits 0–3 BCD 100 mV bits 4–7 BCD volts	1B:	--27	2.7 V
1Ch	1	V <sub>CC</sub> logic supply maximum program/erase voltage bits 0–3 BCD 100 mV bits 4–7 BCD volts	1C:	--36	3.3 V
1Dh	1	V <sub>PP</sub> [programming] supply minimum program/erase voltage bits 0–3 BCD 100 mV bits 4–7 HEX volts	1D:	--B4	11.4 V
20h	1	"n" such that typical max. buffer write time-out = 2 <sup>n</sup> μs	20:	--00	n/a
21h	1	"n" such that typical block erase time-out = 2 <sup>n</sup> ms	21:	--0A	1 s
22h	1	"n" such that typical full chip erase time-out = 2 <sup>n</sup> ms	22:	--00	n/a
23h	1	"n" such that maximum word program time-out = 2 <sup>n</sup> times typical	23:	--04	512 μs
24h	1	"n" such that maximum buffer write time-out = 2 <sup>n</sup> times typical	24:	--00	n/a
25h	1	"n" such that maximum block erase time-out = 2 <sup>n</sup> times typical	25:	--03	8 s
26h	1	"n" such that maximum chip erase time-out = 2 <sup>n</sup> times typical	26:	--00	NA



## B.6 Device Geometry Definition

Table 26. Device Geometry Definition

Offset	Length	Description	Code See Table Below		
27h	1	"n" such that device size = 2 <sup>n</sup> in number of bytes	27:		
28h	2	Flash device interface: <u>x8 async</u> <u>x16 async</u> <u>x8/x16 async</u> 28:00,29:00 28:01,29:00 28:02,29:00	28:	--01	x16
			29:	--00	
2Ah	2	"n" such that maximum number of bytes in write buffer = 2 <sup>n</sup>	2A:	--00	0
			2B:	--00	
2Ch	1	Number of erase block regions within device: 1. x = 0 means no erase blocking; the device erases in "bulk" 2. x specifies the number of device or partition regions with one or more contiguous same-size erase blocks. 3. Symmetrically blocked partitions have one blocking region 4. Partition size = (total blocks) x (individual block size)	2C:	--02	2
2Dh	4	Erase Block Region 1 Information bits 0–15 = y, y+1 = number of identical-size erase blocks bits 16–31 = z, region erase block(s) size are z x 256 bytes	2D:		
			2E:		
			2F:		
			30:		
31h	4	Erase Block Region 2 Information bits 0–15 = y, y+1 = number of identical-size erase blocks bits 16–31 = z, region erase block(s) size are z x 256 bytes	31:		
			32:		
			33:		
			34:		

Device Geometry Definition				
Address	16-Mbit		32-Mbit	
	-B	-T	-B	-T
27:	--15	--15	--16	--16
28:	--01	--01	--01	--01
29:	--00	--00	--00	--00
2A:	--00	--00	--00	--00
2B:	--00	--00	--00	--00
2C:	--02	--02	--02	--02
2D:	--07	--1E	--07	--3E
2E:	--00	--00	--00	--00
2F:	--20	--00	--20	--00
30:	--00	--01	--00	--01
31:	--1E	--07	--3E	--07
32:	--00	--00	--00	--00
33:	--00	--20	--00	--20
34:	--01	--00	--01	--00





## B.7 Intel-Specific Extended Query Table

Certain flash features and commands are optional. The Intel-Specific Extended Query table specifies this and other similar types of information.

**Table 27. Primary-Vendor Specific Extended Query**

Offset <sup>(1)</sup> P = 35h	Length	Description (Optional Flash Features and Commands)	Addr.	Hex Code	Value
(P+0)h (P+1)h (P+2)h	3	Primary extended query table Unique ASCII string "PRI"	35: 36: 37:	--50 --52 --49	"P" "R" "I"
(P+3)h	1	Major version number, ASCII	38:	--31	"1"
(P+4)h	1	Minor version number, ASCII	39:	--30	"0"
(P+5)h (P+6)h (P+7)h (P+8)h	4	Optional feature and command support (1=yes, 0=no) bits 9–31 are reserved; undefined bits are "0." If bit 31 is "1" then another 31 bit field of optional features follows at the end of the bit-30 field.  bit 0 Chip erase supported bit 1 Suspend erase supported bit 2 Suspend program supported bit 3 Legacy lock/unlock supported bit 4 Queued erase supported bit 5 Instant individual block locking supported bit 6 Protection bits supported bit 7 Page mode read supported bit 8 Synchronous read supported	3A: 3B: 3C: 3D:	--66 --00 --00 --00	    No Yes Yes No No Yes Yes No No
(P+9)h	1	Supported functions after suspend: read array, status, query Other supported operations are: <i>bits 1–7 reserved; undefined bits are "0"</i> bit 0 Program supported after erase suspend	3E:	--01	  Yes
(P+A)h (P+B)h	2	Block status register mask bits 2–15 are Reserved; undefined bits are "0" bit 0 Block Lock-Bit Status register active bit 1 Block Lock-Down Bit Status active	3F: 40:	--03 --00	  Yes Yes
(P+C)h	1	V <sub>CC</sub> logic supply highest performance program/erase voltage bits 0–3 BCD value in 100 mV bits 4–7 BCD value in volts	41:	--33	3.3 V
(P+D)h	1	V <sub>PP</sub> optimum program/erase supply voltage bits 0–3 BCD value in 100 mV bits 4–7 HEX value in volts	42:	--C0	12.0 V

Table 28. Protection Register Information

Offset <sup>(1)</sup> P = 35h	Length	Description (Optional Flash Features and Commands)	Addr.	Hex Code	Value
(P+E)h	1	Number of Protection register fields in JEDEC ID space. "00h," indicates that 256 protection bytes are available	43:	--01	01
(P+F)h	4	Protection Field 1: Protection Description This field describes user-available One Time Programmable (OTP) Protection register bytes. Some are pre-programmed with device-unique serial numbers. Others are user programmable. Bits 0–15 point to the Protection register Lock byte, the section's first byte. The following bytes are factory pre-programmed and user-programmable.	44:	--80	80h
(P+10)h		bits 0–15 = Lock/bytes JEDEC -plane physical low address	45:	--00	00h
(P+11)h		bits 16–23 = "n" such that 2 <sup>n</sup> = factory pre- programmed bytes	46:	--03	8 byte
(P+12)h		bits 24–31 = "n" such that 2 <sup>n</sup> = user programmable bytes	47:	--03	8 byte
(P+13)h		<i>Reserved for future use</i>	48:		

**NOTE:** 1. The variable P is a pointer which is defined at CFI offset 15h.



## Appendix C Word-Wide Memory Map Diagrams

16-Mbit, 32-Mbit 64-Mbit [future], Word-Wide Memory Addressing							
Top Boot				Bottom Boot			
Size (KW)	16-Mbit	32-Mbit	64-Mbit	Size (KW)	16-Mbit	32-Mbit	64-Mbit
4	FF000-FFFF	1FF000-1FFFF	3FF000-3FFFF	32			3F8000-3FFFF
4	FE000-FEFFF	1FE000-1FEFFF	3FE000-3FEFFF	32			3F0000-3F7FFF
4	FD000-FDFFF	1FD000-1FDFFF	3FD000-3FDFFF	32			3E8000-3E7FFF
4	FC000-FCFFF	1FC000-1FCFFF	3FC000-3FCFFF	32			3E0000-3E7FFF
4	FB000-FBFFF	1FB000-1FBFFF	3FB000-3FBFFF	32			3D8000-3D7FFF
4	FA000-FAFFF	1FA000-1FAFFF	3FA000-3FAFFF	32			3D0000-3D7FFF
4	F9000-F9FFF	1F9000-1F9FFF	3F9000-3F9FFF	32			3C8000-3C7FFF
4	F8000-F8FFF	1F8000-1F8FFF	3F8000-3F8FFF	32			3C0000-3C7FFF
32	F0000-F7FFF	1F0000-1F7FFF	3F0000-3F7FFF	32			3B8000-3B7FFF
32	E8000-E7FFF	1E8000-1E7FFF	3E8000-3E7FFF	32			3B0000-3B7FFF
32	E0000-E7FFF	1E0000-1E7FFF	3E0000-3E7FFF	32			3A8000-3A7FFF
32	D8000-D7FFF	1D8000-1D7FFF	3D8000-3D7FFF	32			3A0000-3A7FFF
32	D0000-D7FFF	1D0000-1D7FFF	3D0000-3D7FFF	32			398000-397FFF
32	C8000-C7FFF	1C8000-1C7FFF	3C8000-3C7FFF	32			390000-387FFF
32	C0000-C7FFF	1C0000-1C7FFF	3C0000-3C7FFF	32			388000-387FFF
32	B8000-B7FFF	1B8000-1B7FFF	3B8000-3B7FFF	32			380000-377FFF
32	B0000-B7FFF	1B0000-1B7FFF	3B0000-3B7FFF	32			378000-377FFF
32	A8000-A7FFF	1A8000-1A7FFF	3A8000-3A7FFF	32			370000-377FFF
32	A0000-A7FFF	1A0000-1A7FFF	3A0000-3A7FFF	32			368000-367FFF
32	98000-97FFF	198000-197FFF	398000-397FFF	32			360000-357FFF
32	90000-97FFF	190000-197FFF	390000-397FFF	32			358000-357FFF
32	88000-87FFF	188000-187FFF	388000-387FFF	32			350000-347FFF
32	80000-87FFF	180000-187FFF	380000-387FFF	32			348000-347FFF
32	78000-77FFF	178000-177FFF	378000-377FFF	32			340000-347FFF
32	70000-77FFF	170000-177FFF	370000-377FFF	32			338000-337FFF
32	68000-67FFF	168000-167FFF	368000-367FFF	32			330000-327FFF
32	60000-67FFF	160000-167FFF	360000-367FFF	32			328000-327FFF
32	58000-57FFF	158000-157FFF	358000-357FFF	32			320000-317FFF
32	50000-57FFF	150000-157FFF	350000-357FFF	32			318000-317FFF
32	48000-47FFF	148000-147FFF	348000-347FFF	32			310000-317FFF
32	40000-47FFF	140000-147FFF	340000-347FFF	32			308000-307FFF
32	38000-37FFF	138000-137FFF	338000-337FFF	32			300000-307FFF
32	30000-37FFF	130000-137FFF	330000-337FFF	32			2F8000-2F7FFF
32	28000-27FFF	128000-127FFF	328000-327FFF	32			2F0000-2F7FFF
32	20000-27FFF	120000-127FFF	320000-327FFF	32			2E8000-2E7FFF
32	18000-17FFF	118000-117FFF	318000-317FFF	32			2E0000-2E7FFF
32	10000-17FFF	110000-117FFF	310000-317FFF	32			2D8000-2D7FFF
32	08000-07FFF	108000-107FFF	308000-307FFF	32			2D0000-2D7FFF
32	00000-07FFF	100000-107FFF	300000-307FFF	32			2C8000-2C7FFF
32		0F8000-0F7FFF	2F8000-2F7FFF	32			2C0000-2C7FFF
32		0F0000-0F7FFF	2F0000-2F7FFF	32			2B8000-2B7FFF
32		0E8000-0E7FFF	2E8000-2E7FFF	32			2B0000-2B7FFF
32		0E0000-0E7FFF	2E0000-2E7FFF	32			2A8000-2A7FFF
32		0D8000-0D7FFF	2D8000-2D7FFF	32			2A0000-2A7FFF
32		0D0000-0D7FFF	2D0000-2D7FFF	32			298000-297FFF
32		0C8000-0C7FFF	2C8000-2C7FFF	32			290000-297FFF
32		0C0000-0C7FFF	2C0000-2C7FFF	32			288000-287FFF
32		0B8000-0B7FFF	2B8000-2B7FFF	32			280000-287FFF
32		0B0000-0B7FFF	2B0000-2B7FFF	32			278000-277FFF
32		0A8000-0A7FFF	2A8000-2A7FFF	32			270000-277FFF

This column continues on next page

This column continues on next page



16-Mbit, 32-Mbit, and 64-Mbit [future], Word-Wide Memory Addressing							
Top Boot				Bottom Boot			
Size (KW)	16-Mbit	32-Mbit	64-Mbit	Size (KW)	16-Mbit	32-Mbit	64-Mbit
32		0A0000-0A7FFF	2A0000-2A7FFF	32			268000-26FFFF
32		098000-09FFFF	298000-29FFFF	32			260000-267FFF
32		090000-097FFF	290000-297FFF	32			258000-25FFFF
32		088000-08FFFF	288000-28FFFF	32			250000-257FFF
32		080000-087FFF	280000-287FFF	32			248000-24FFFF
32		078000-077FFF	278000-277FFF	32			240000-247FFF
32		070000-077FFF	270000-277FFF	32			238000-23FFFF
32		068000-06FFFF	268000-26FFFF	32			230000-237FFF
32		060000-067FFF	260000-267FFF	32			228000-22FFFF
32		058000-05FFFF	258000-25FFFF	32			220000-227FFF
32		050000-057FFF	250000-257FFF	32			218000-21FFFF
32		048000-04FFFF	248000-24FFFF	32			210000-217FFF
32		040000-047FFF	240000-247FFF	32			208000-20FFFF
32		038000-03FFFF	238000-23FFFF	32			200000-207FFF
32		030000-037FFF	230000-237FFF	32		1F8000-1FFFFF	1F8000-1FFFFF
32		028000-02FFFF	228000-22FFFF	32		1F0000-1F7FFF	1F0000-1F7FFF
32		020000-027FFF	220000-227FFF	32		1E8000-1EFFFF	1E8000-1EFFFF
32		018000-01FFFF	218000-21FFFF	32		1E0000-1E7FFF	1E0000-1E7FFF
32		010000-017FFF	210000-217FFF	32		1D8000-1DFFFF	1D8000-1DFFFF
32		008000-00FFFF	208000-21FFFF	32		1D0000-1D7FFF	1D0000-1D7FFF
32		000000-007FFF	200000-207FFF	32		1C8000-1CFFFF	1C8000-1CFFFF
32			1F8000-1FFFFF	32		1C0000-1C7FFF	1C0000-1C7FFF
32			1F0000-1F7FFF	32		1B8000-1BFFFF	1B8000-1BFFFF
32			1E8000-1EFFFF	32		1B0000-1B7FFF	1B0000-1B7FFF
32			1E0000-1E7FFF	32		1A8000-1AFFFF	1A8000-1AFFFF
32			1D8000-1DFFFF	32		1A0000-1A7FFF	1A0000-1A7FFF
32			1D0000-1D7FFF	32		198000-19FFFF	198000-19FFFF
32			1C8000-1CFFFF	32		190000-197FFF	190000-197FFF
32			1C0000-1C7FFF	32		188000-18FFFF	188000-18FFFF
32			1B8000-1BFFFF	32		180000-187FFF	180000-187FFF
32			1B0000-1B7FFF	32		178000-17FFFF	178000-17FFFF
32			1A8000-1AFFFF	32		170000-177FFF	170000-177FFF
32			1A0000-1A7FFF	32		168000-16FFFF	168000-16FFFF
32			198000-19FFFF	32		160000-167FFF	160000-167FFF
32			190000-197FFF	32		158000-15FFFF	158000-15FFFF
32			188000-18FFFF	32		150000-157FFF	150000-157FFF
32			180000-187FFF	32		148000-14FFFF	148000-14FFFF
32			178000-17FFFF	32		140000-147FFF	140000-147FFF
32			170000-177FFF	32		138000-13FFFF	138000-13FFFF
32			168000-16FFFF	32		130000-137FFF	130000-137FFF
32			160000-167FFF	32		128000-12FFFF	128000-12FFFF
32			158000-15FFFF	32		120000-127FFF	120000-127FFF
32			150000-157FFF	32		118000-11FFFF	118000-11FFFF
32			148000-14FFFF	32		110000-117FFF	110000-117FFF
32			140000-147FFF	32		108000-10FFFF	108000-10FFFF
32			138000-13FFFF	32		100000-107FFF	100000-107FFF
32			130000-137FFF	32	F8000-FFFFF	F8000-FFFFF	F8000-FFFFF
32			128000-12FFFF	32	F0000-F7FFF	F0000-F7FFF	F0000-F7FFF
32			120000-127FFF	32	E8000-EFFFF	E8000-EFFFF	E8000-EFFFF
32			118000-11FFFF	32	E0000-E7FFF	E0000-E7FFF	E0000-E7FFF
32			110000-117FFF	32	D8000-DFFFF	D8000-DFFFF	D8000-DFFFF
32			108000-10FFFF	32	D0000-D7FFF	D0000-D7FFF	D0000-D7FFF
32			100000-107FFF	32	C8000-CFFFF	C8000-CFFFF	C8000-CFFFF
32			0F8000-0FFFFF	32	C0000-C7FFF	C0000-C7FFF	C0000-C7FFF

This column continues on next page

This column continues on next page



3 Volt Intel® Advanced+ Boot Block Flash Memory Stacked-CSP Family

16-Mbit, 32-Mbit, and 64-Mbit Word-Wide Memory Addressing

Top Boot				Bottom Boot			
Size (KW)	16-Mbit	32-Mbit	64-Mbit	Size (KW)	16-Mbit	32-Mbit	64-Mbit
32			0F0000-0F7FFF	32	B8000-BFFFFF	B8000-BFFFFF	B8000-BFFFFF
32			0E8000-0EFFFF	32	B0000-B7FFF	B0000-B7FFF	B0000-B7FFF
32			0E0000-0E7FFF	32	A8000-AFFFFF	A8000-AFFFFF	A8000-AFFFFF
32			0D8000-0DFFFF	32	A0000-A7FFF	A0000-A7FFF	A0000-A7FFF
32			0D0000-0D7FFF	32	98000-9FFFFF	98000-9FFFFF	98000-9FFFFF
32			0C8000-0CFFFF	32	90000-97FFF	90000-97FFF	90000-97FFF
32			0C0000-0C7FFF	32	88000-8FFFFF	88000-8FFFFF	88000-8FFFFF
32			0B8000-0BFFFF	32	80000-87FFF	80000-87FFF	80000-87FFF
32			0B0000-0B7FFF	32	78000-7FFFF	78000-7FFFF	78000-7FFFF
32			0A8000-0AFFFF	32	70000-77FFF	70000-77FFF	70000-77FFF
32			0A0000-0A7FFF	32	68000-6FFFF	68000-6FFFF	68000-6FFFF
32			098000-09FFFF	32	60000-67FFF	60000-67FFF	60000-67FFF
32			090000-097FFF	32	58000-5FFFF	58000-5FFFF	58000-5FFFF
32			088000-08FFFF	32	50000-57FFF	50000-57FFF	50000-57FFF
32			080000-087FFF	32	48000-4FFFF	48000-4FFFF	48000-4FFFF
32			078000-07FFFF	32	40000-47FFF	40000-47FFF	40000-47FFF
32			070000-077FFF	32	38000-3FFFF	38000-3FFFF	38000-3FFFF
32			068000-06FFFF	32	30000-37FFF	30000-37FFF	30000-37FFF
32			060000-067FFF	32	28000-2FFFF	28000-2FFFF	28000-2FFFF
32			058000-05FFFF	32	20000-27FFF	20000-27FFF	20000-27FFF
32			050000-057FFF	32	18000-1FFFF	18000-1FFFF	18000-1FFFF
32			048000-04FFFF	32	10000-17FFF	10000-17FFF	10000-17FFF
32			040000-047FFF	32	08000-0FFFF	08000-0FFFF	08000-0FFFF
32			038000-03FFFF	4	07000-07FFF	07000-07FFF	07000-07FFF
32			030000-037FFF	4	06000-06FFF	06000-06FFF	06000-06FFF
32			028000-02FFFF	4	05000-05FFF	05000-05FFF	05000-05FFF
32			020000-027FFF	4	04000-04FFF	04000-04FFF	04000-04FFF
32			018000-01FFFF	4	03000-03FFF	03000-03FFF	03000-03FFF
32			010000-017FFF	4	02000-02FFF	02000-02FFF	02000-02FFF
32			008000-00FFFF	4	01000-01FFF	01000-01FFF	01000-01FFF
32			000000-007FFF	4	00000-00FFF	00000-00FFF	00000-00FFF



## Appendix D Device ID Table

Table 29. Device ID

Read Configuration Address and Data

Item		Address	Data
Manufacturer Code	x16	00000	0089
Device Code			
16-Mbit x 16-T	x16	00001	88C2
16-Mbit x 16-B	x16	00001	88C3
32-Mbit x 16-T	x16	00001	88C4
32-Mbit x 16-B	x16	00001	88C5

**NOTE:** Other locations within the configuration address space are reserved by Intel for future use.



## Appendix E Protection Register Addressing

Table 30. Protection Register Addressing

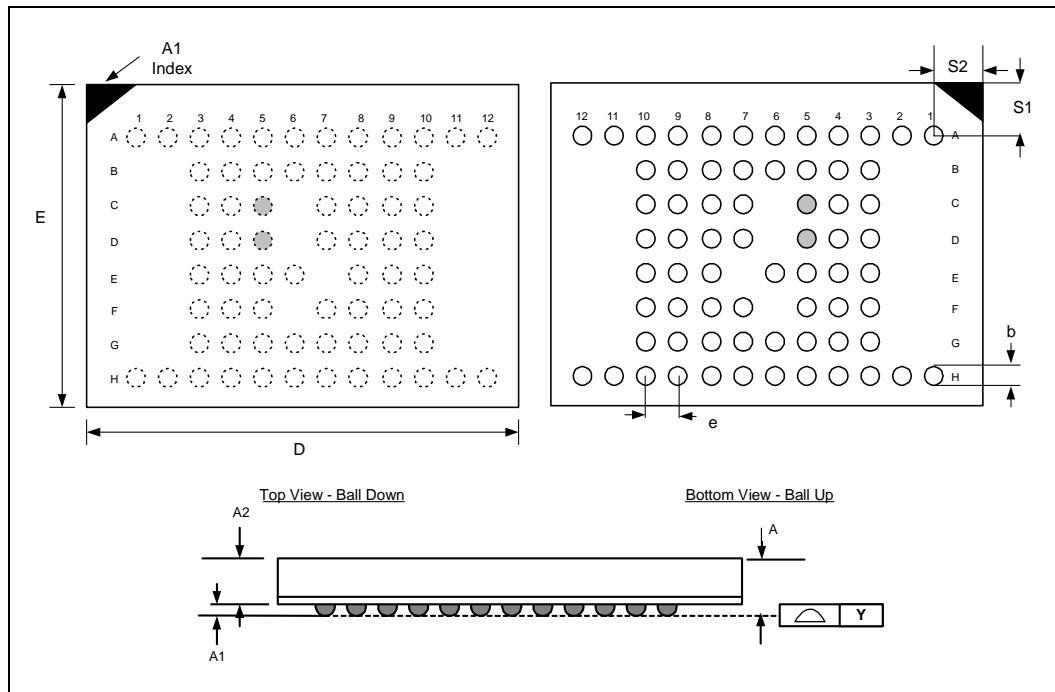
Word-Wide Protection Register Addressing									
Word	Use	A7	A6	A5	A4	A3	A2	A1	A0
LOCK	Both	1	0	0	0	0	0	0	0
0	Factory	1	0	0	0	0	0	0	1
1	Factory	1	0	0	0	0	0	1	0
2	Factory	1	0	0	0	0	0	1	1
3	Factory	1	0	0	0	0	1	0	0
4	User	1	0	0	0	0	1	0	1
5	User	1	0	0	0	0	1	1	0
6	User	1	0	0	0	0	1	1	1
7	User	1	0	0	0	1	0	0	0

**NOTE:** All address lines not specified in the above table must be 0 when accessing the Protection Register, i.e.,  $A_{21\_A_8} = 0$ .

## Appendix F Mechanical and Shipping Media Details

### F.1 Mechanical Specification

Figure 21. Stacked-CSP: 12 x 8 Ball Matrix



**NOTE:** Shaded pins indicate upper address balls for 64-Mbit and 128-Mbit devices. In all Flash and SRAM combinations, 66 balls are populated on lower density devices. (Upper address balls are not populated).





**Table 31. Packaging Specifications (0.18µm and 0.25µm)**

	Sym	Millimeters			Inches		
		Min	Nom	Max	Min	Nom	Max
Package Height	A			1.400			0.0551
Ball Height	A1	0.250			0.0098		
Package Body Thickness	A2		0.960			0.0378	
Ball Lead Diameter	b	0.350	0.400	0.450	0.0138	0.0157	0.0177
Package Body Length – 16-Mbit/2-Mbit	D	9.900	10.00	10.100	0.3898	0.3937	0.3976
Package Body Length – 32-Mbit/4-Mbit, 16-Mbit/4-Mbit		11.900	12.000	12.100	0.4685	0.4724	0.4764
Package Body Length – 32-Mbit/8-Mbit		13.900	14.000	14.100	0.5472	0.5512	0.5551
Package Body Width – 16-Mbit/2-Mbit, 16-Mbit/4-Mbit, 32-Mbit/4-Mbit, 32-Mbit/8-Mbit	E	7.900	8.000	8.100	0.3110	0.3150	0.3189
Pitch	e		0.800			0.0315	
Ball (Lead) Count	N		66			66	
Seating Plane Coplanarity	Y			0.100			0.0039
Corner to Ball A1 Distance Along E 16-Mbit/2-Mbit, 16-Mbit/4-Mbit, 32-Mbit/4-Mbit, 32-Mbit/8-Mbit	S1	1.100	1.200	1.300	0.0433	0.0472	0.0512
Corner to Ball A1 Distance Along D 16-Mbit/2-Mbit	S2	0.500	0.600	0.700	0.0197	0.0236	0.0276
Corner to Ball A1 Distance Along D 32-Mbit/4-Mbit, 16-Mbit/4-Mbit		1.500	1.600	1.700	0.0591	0.0630	0.0669
Corner to Ball A1 Distance Along D 32-Mbit/8-Mbit		2.500	2.600	2.700	0.0984	0.1024	0.1063

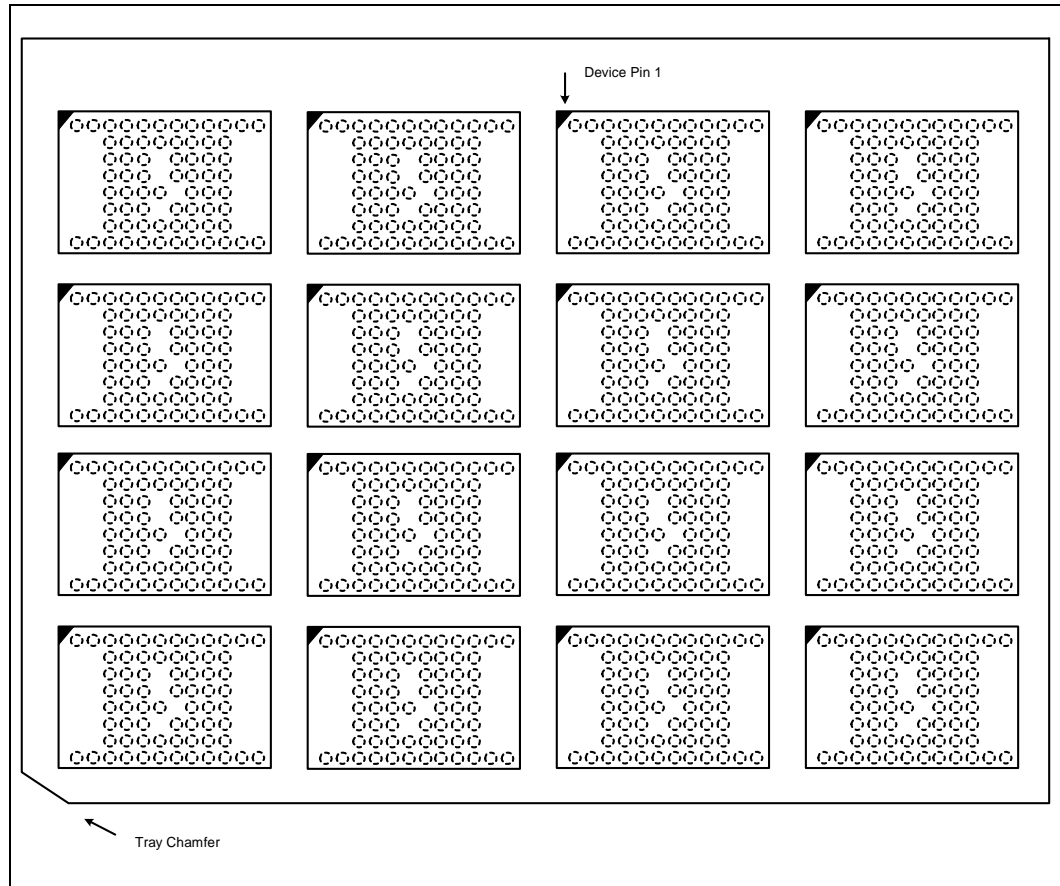


**Table 32. Packaging Specifications (0.13µm)**

	Sym	Millimeters			Inches		
		Min	Nom	Max	Min	Nom	Max
Package Height 16/02-Mb, 16/04-Mb, 32/08-Mb	A			1.200			0.0472
Package Height 32/04-Mb				1.400			0.0551
Ball Height 16/02-Mb, 16/04-Mb, 32/08-Mb	A1	0.200			0.0079		
Ball Height 32/04-Mb		0.250			0.0098		
Package Body Thickness 16/02-Mb, 16/04-Mb, 32/08-Mb	A2		0.860			0.0339	
Package Body Thickness 32/04-Mb			0.960			0.0378	
Ball (Lead) Width 16/02-Mb, 16/04-Mb, 32/08-Mb	b	0.325	0.375	0.425	0.0128	0.0148	0.0167
Ball (Lead) Width 32/04-Mb		0.350	0.40	0.450	0.0138	0.0157	0.0177
Package Body Length 16/02-Mb, 16/04-Mb	D	9.900	10.000	10.100	0.3898	0.3937	0.3976
Package Body Length 32/04-Mb, 32/08-Mb		11.900	12.000	12.100	0.4685	0.4724	0.4764
Package Body Width 16/02-Mb, 16/04-Mb, 32/04-Mb, 32/08-Mb	E	7.900	8.000	8.100	0.3110	0.3150	0.3189
Pitch	e		0.800			0.0315	
Ball (Lead) Count	N		66			66	
Seating Plane Coplanarity	Y			0.100			0.0039
Corner to Ball A1 Distance Along E 16/02-Mb, 16/04-Mb, 32/04-Mb, 32/08-Mb	S1	1.100	1.200	1.300	0.0433	0.0472	0.0512
Corner to Ball A1 Distance Along D 16/02-Mb, 16/04-Mb	S2	0.500	0.600	0.700	0.0197	0.0236	0.0276
Corner to Ball A1 Distance Along D 32/04-Mb, 32/08-Mb	S2	1.500	1.600	1.700	0.0591	0.0630	0.0669

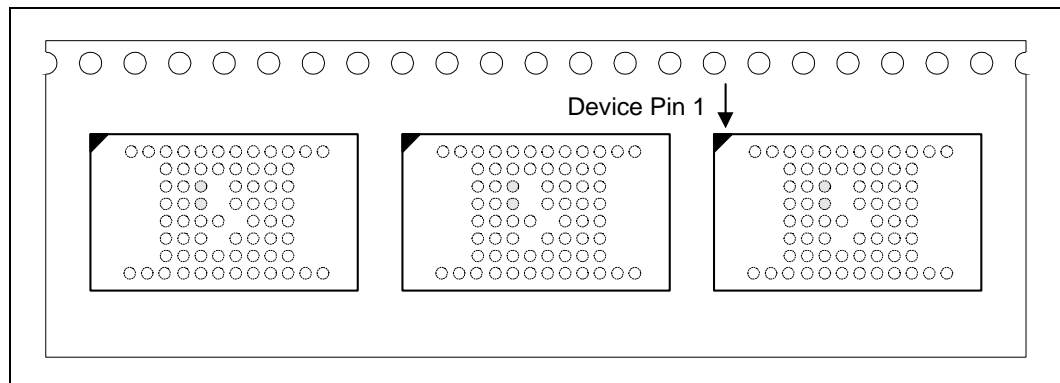
## F.2 Media Information

Figure 22. Stacked-CSP Device in Tray Orientation (8 mm x 10 mm and 8 mm x 12 mm)



NOTE: Drawing is not to scale and is only designed to show orientation of devices.

Figure 23. Stacked-CSP Device in 24 mm Tape (8 mm x 10 mm and 8 mm x 12 mm)





## Appendix G Additional Information

Order Number	Document/Tool
292216	<i>AP-658 Designing for Upgrade to the Advanced+ Boot Block Flash Memory</i>
292215	<i>AP-657 Designing with the Advanced+ Boot Block Flash Memory Architecture</i>
Contact Your Intel Representative	<i>Flash Data Integrator (FDI) Software Developer's Kit</i>
297874	<i>FDI Interactive: Play with Intel's Flash Data Integrator on Your PC</i>

**NOTES:**

1. Please call the Intel Literature Center at (800) 548-4725 to request Intel documentation. International customers should contact their local Intel or distribution sales office.
2. Visit Intel's World Wide Web home page at <http://www.Intel.com> or <http://developer.intel.com> for technical documentation and tools.



## Appendix H Ordering Information

Table 33. Ordering Information for 0.25 µm and 0.18 µm

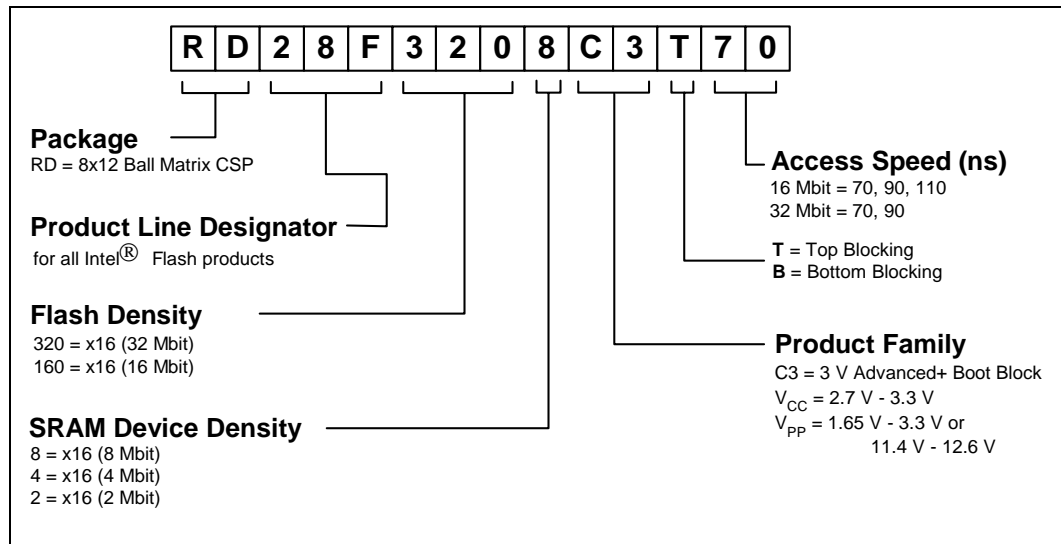


Table 34. Ordering Information for Combinations with 16M 0.13 µm Flash

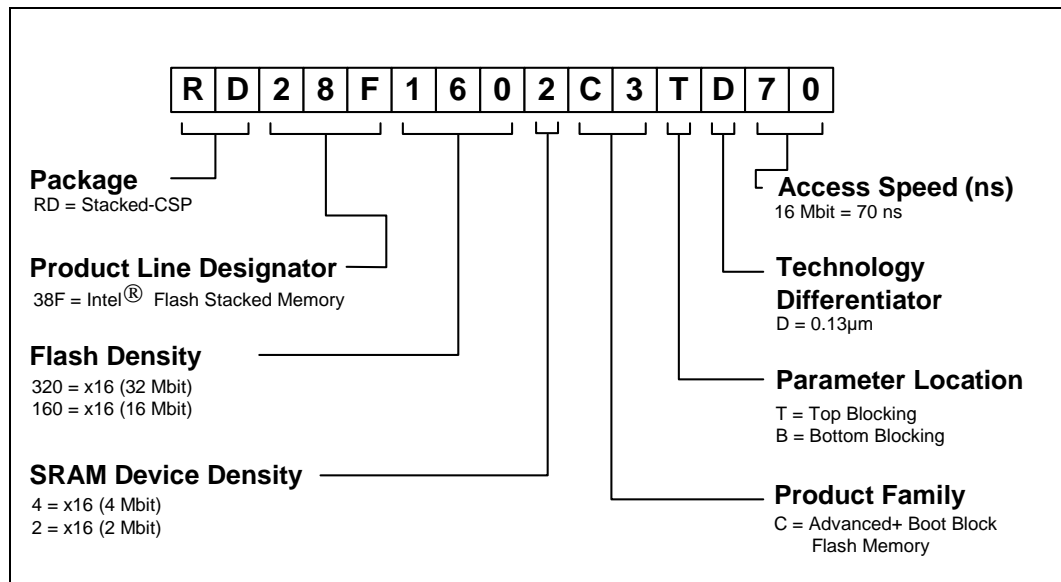




Table 35. Ordering Information for Combinations with 32M 0.13 µm Flash

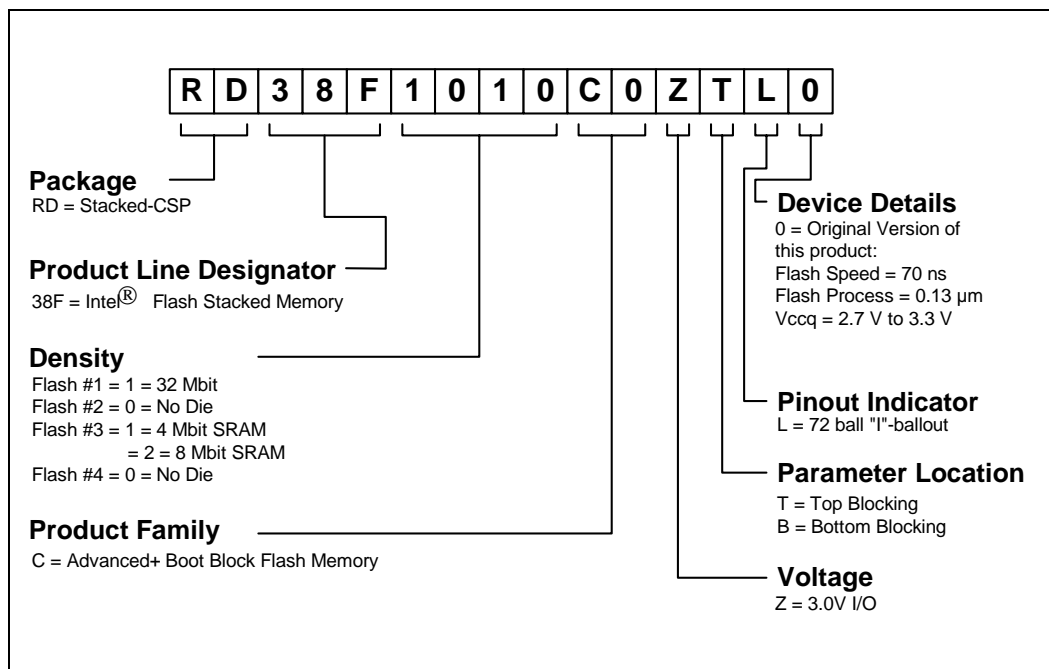


Table 36. Ordering Information Valid Combinations

	0.25µm C3 Stacked-CSP	0.18µm C3 Stacked-CSP	0.13µm C3 Stacked-CSP
32-Mbit	No longer available.	RD28F3208C3T70 RD28F3208C3B70 RD28F3208C3T90 RD28F3208C3B90 RD28F3204C3T70 RD28F3204C3B70	RD38F1010C0ZTL0 RD38F1010C0ZBL0 RD38F1020C0ZTL0 RD38F1020C0ZBL0
16-Mbit	RD28F1604C3T90 RD28F1604C3B90 RD28F1604C3T110 RD28F1604C3B110 RD28F1602C3T90 RD28F1602C3B90 RD28F1602C3T110 RD28F1602C3B110	RD28F1602C3T70 RD28F1602C3B70	RD28F1602C3TD70 RD28F1602C3BD70 RD28F1604C3TD70 RD28F1604C3BD70