



RD65FV

Rectifier Diode Target Information

DS5408-2.0 October 2001

Replaces November 2000, version DS5408-1.1

FEATURES

- Optimised For High Current Rectifiers
- High Surge Capability
- Very Low On-state Voltage

APPLICATIONS

- Electroplating
- Power Supplies
- Welding

VOLTAGE RATINGS

Part and Ordering Number	Repetitive Peak Reverse Voltage V_{RRM} V	Conditions
RD65FV06	600	$V_{RSM} = V_{RRM}$
RD65FV05	500	
RD65FV04	400	
RD65FV03	300	
RD65FV02	200	
RD65FV01	100	

KEY PARAMETERS

V_{RRM}		600V
$I_{F(AV)}$	(max)	11745A
I_{FSM}	(max)	162000A

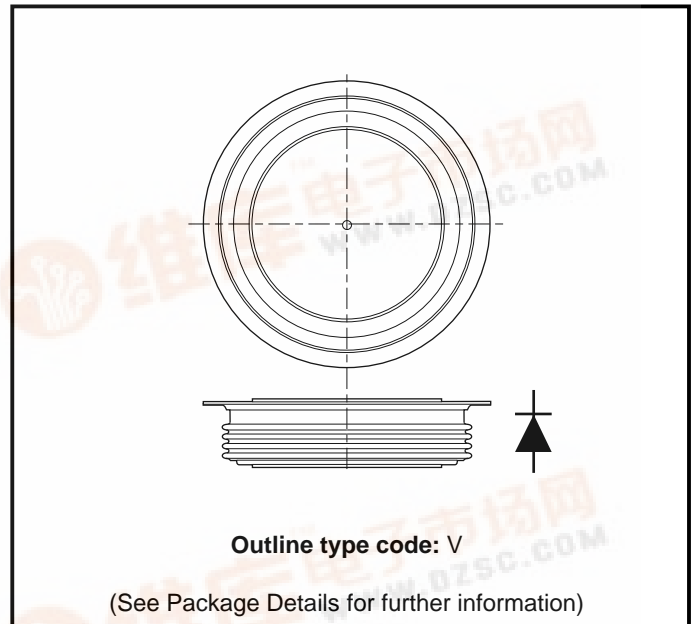

Fig. 1 Package outline

ORDERING INFORMATION

When ordering, select the required part number shown in the Voltage Ratings selection table.

For example:

RD65FV04

Note: Please use the complete part number when ordering and quote this number in any future correspondence relating to your order.

CURRENT RATINGS

 $T_{\text{case}} = 75^{\circ}\text{C}$ unless otherwise stated

Symbol	Parameter	Conditions	Max.	Units
Double Side Cooled				
$I_{F(AV)}$	Mean forward current	Half wave resistive load	11745	A
$I_{F(RMS)}$	RMS value	-	18450	A
I_F	Continuous (direct) forward current	-	16974	A
Single Side Cooled (Anode side)				
$I_{F(AV)}$	Mean forward current	Half wave resistive load	7632	A
$I_{F(RMS)}$	RMS value	-	11988	A
I_F	Continuous (direct) forward current	-	10079	A

 $T_{\text{case}} = 85^{\circ}\text{C}$ unless otherwise stated

Symbol	Parameter	Test Conditions	Max.	Units
Double Side Cooled				
$I_{F(AV)}$	Mean forward current	Half wave resistive load	11120	A
$I_{F(RMS)}$	RMS value	-	17500	A
I_F	Continuous (direct) forward current	-	16000	A
Single Side Cooled				
$I_{F(AV)}$	Mean forward current	Half wave resistive load	7200	A
$I_{F(RMS)}$	RMS value	-	11300	A
I_F	Continuous (direct) forward current	-	9450	A

SURGE RATINGS

Symbol	Parameter	Test Conditions	Max.	Units
I_{FSM}	Surge (non-repetitive) forward current	10ms half sine, $T_{case} = 175^{\circ}C$	130	kA
I^2t	I^2t for fusing	$V_R = 50\% V_{RRM}$ - 1/4 sine	84.5×10^6	A ² s
I_{FSM}	Surge (non-repetitive) forward current	10ms half sine, $T_{case} = 175^{\circ}C$	162	kA
I^2t	I^2t for fusing	$V_R = 0$	132×10^6	A ² s

THERMAL AND MECHANICAL RATINGS

Symbol	Parameter	Test Conditions	Min.	Max.	Units	
$R_{th(j-c)}$	Thermal resistance - junction to case	Double side cooled	DC	-	0.0075	$^{\circ}C/W$
		Single side cooled	Anode DC	-	0.015	$^{\circ}C/W$
			Cathode DC	-	0.015	$^{\circ}C/W$
$R_{th(c-h)}$	Thermal resistance - case to heatsink	Clamping force 43.0kN	Double side	-	0.002	$^{\circ}C/W$
		(with mounting compound)	Single side	-	0.004	$^{\circ}C/W$
T_{vj}	Virtual junction temperature	Forward (conducting)		-	225	$^{\circ}C$
		Reverse (blocking)		-	200	$^{\circ}C$
T_{stg}	Storage temperature range		-55	200	$^{\circ}C$	
F_m	Clamping force		38.7	47.3	kN	

CHARACTERISTICS

Symbol	Parameter	Test Conditions	Min.	Max.	Units
I_{RM}	Peak reverse current	At V_{RRM} , $T_{case} = 200^{\circ}C$	-	150	mA
I_{rr}	Peak reverse recovery current	$I_F = 2000A$, $di_{RR}/dt = 3A/\mu s$,	-	230	A
Q_S	Total stored charge	$T_{case} = 200^{\circ}C$, $V_R = 100V$	-	39	μC
V_{TO}	Threshold voltage	At $T_{vj} = 200^{\circ}C$	-	0.6	V
r_T	Slope resistance	At $T_{vj} = 200^{\circ}C$	-	0.0225	m Ω

CURVES

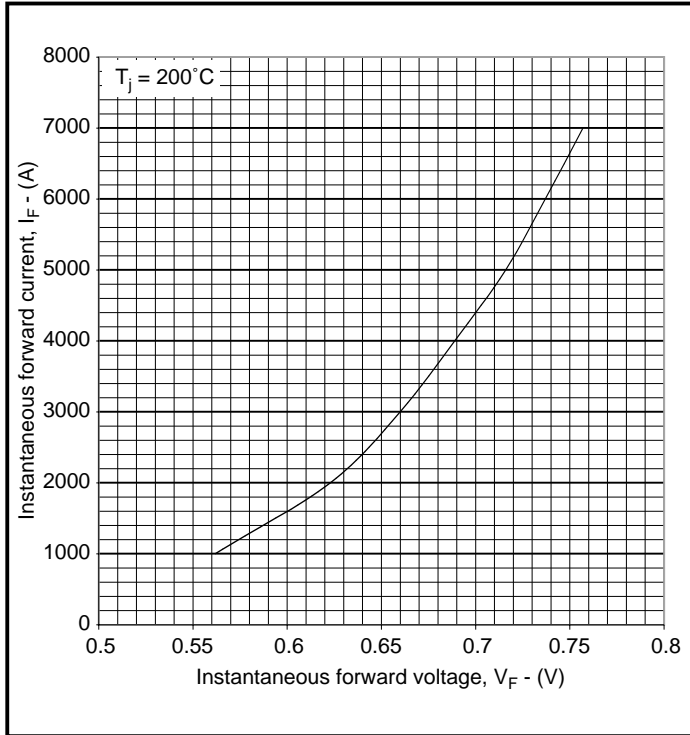

Fig. 2 Maximum (limit) forward characteristics

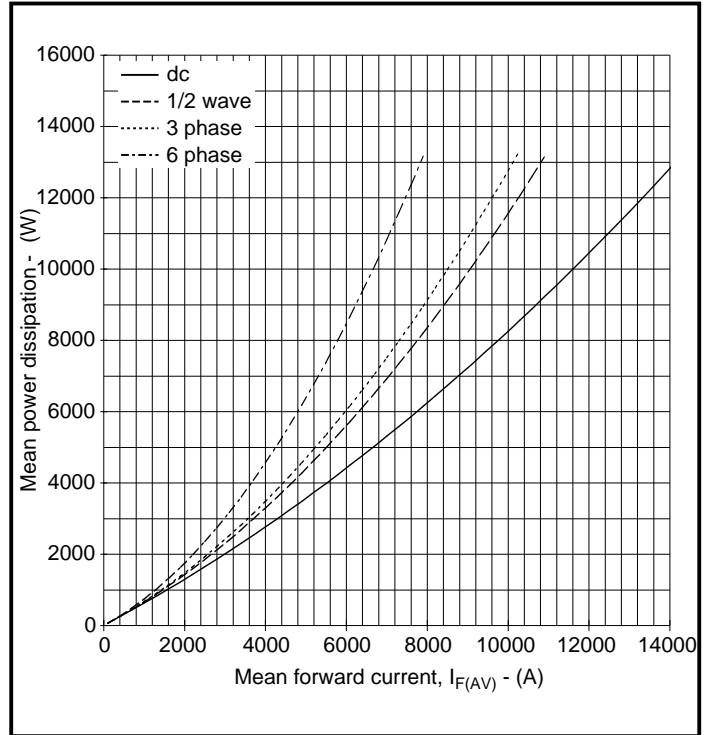

Fig. 3 Power dissipation

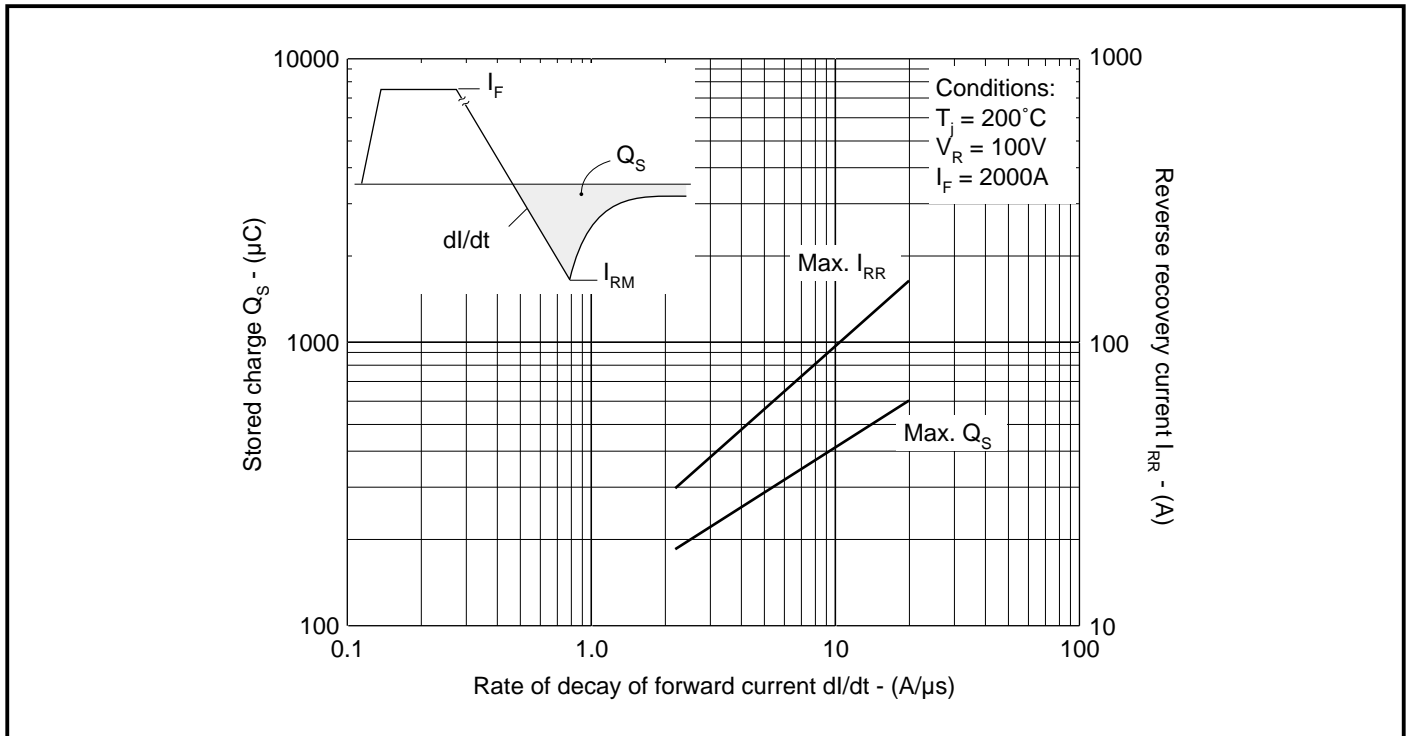

Fig. 4 Maximum stored charge and reverse recovery current vs di/dt

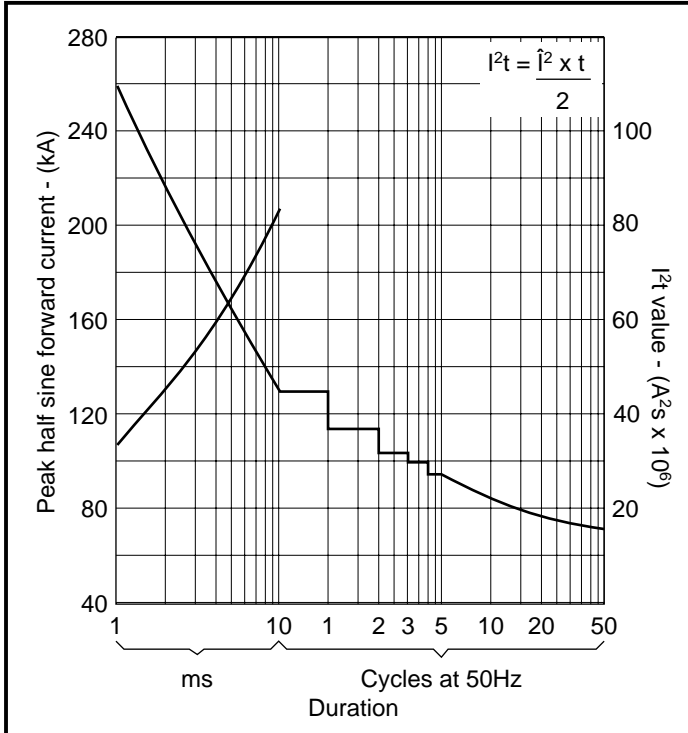

Fig. 5 Surge (non-repetitive) forward current vs time
(with 50% V_{RRM} @ $T_{case} = 175^{\circ}C$)

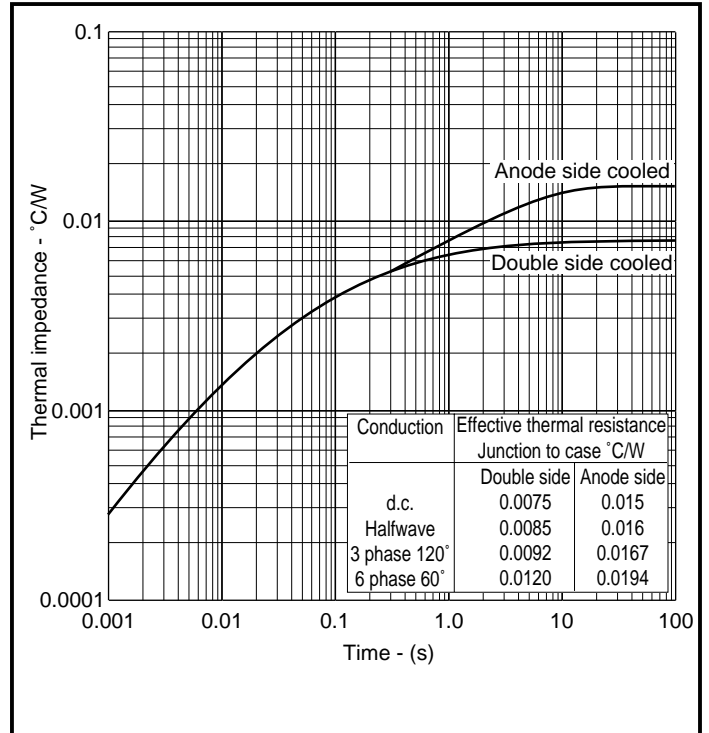
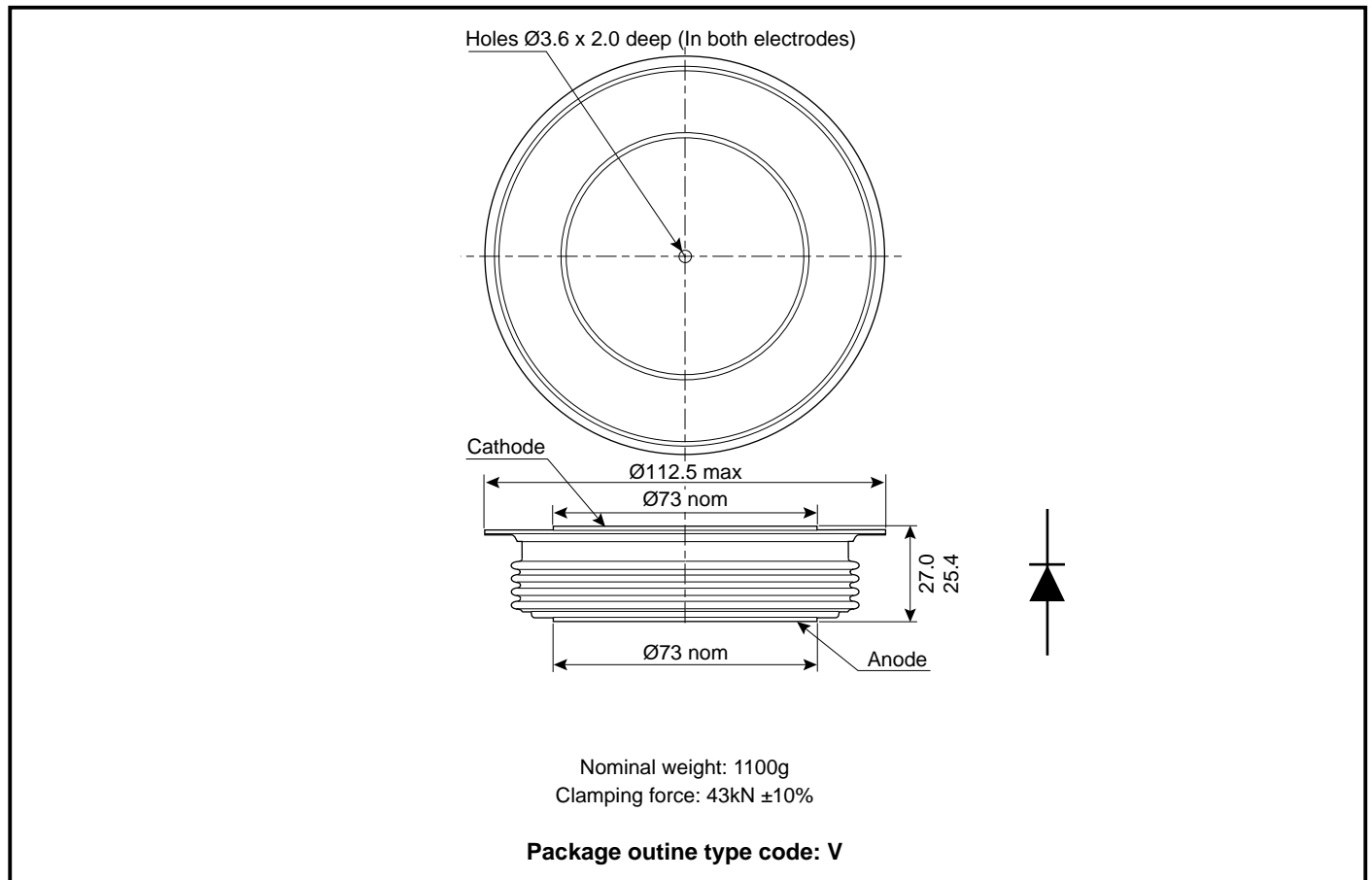

Fig. 6 Maximum (limit) transient thermal impedance

PACKAGE DETAILS

For further package information, please visit our website or contact your nearest Customer Service Centre. All dimensions in mm, unless stated otherwise. DO NOT SCALE.



Note:

1. Package maybe supplied with pins and/or tags.

POWER ASSEMBLY CAPABILITY

The Power Assembly group was set up to provide a support service for those customers requiring more than the basic semiconductor, and has developed a flexible range of heatsink / clamping systems in line with advances in device types and the voltage and current capability of our semiconductors.

We offer an extensive range of air and liquid cooled assemblies covering the full range of circuit designs in general use today. The Assembly group continues to offer high quality engineering support dedicated to designing new units to satisfy the growing needs of our customers.

Using the up to date CAD methods our team of design and applications engineers aim to provide the Power Assembly Complete solution (PACs).

DEVICE CLAMPS

Disc devices require the correct clamping force to ensure their safe operation. The PACs range offers a varied selection of pre-loaded clamps to suit all of our manufactured devices. This include cube clamps for single side cooling of 'T' 22mm

Clamps are available for single or double side cooling, with high insulation versions for high voltage assemblies.

Please refer to our application note on device clamping, AN4839

HEATSINKS

Power Assembly has its own proprietary range of extruded aluminium heatsinks. They have been designed to optimise the performance or our semiconductors. Data with respect to air natural, forced air and liquid cooling (with flow rates) is available on request.

For further information on device clamps, heatsinks and assemblies, please contact your nearest Sales Representative or Customer Services.



<http://www.dynexsemi.com>

e-mail: power_solutions@dynexsemi.com

HEADQUARTERS OPERATIONS

DYNEX SEMICONDUCTOR LTD

Doddington Road, Lincoln.
Lincolnshire. LN6 3LF. United Kingdom.
Tel: 00-44-(0)1522-500500
Fax: 00-44-(0)1522-500550

DYNEX POWER INC.

99 Bank Street, Suite 410,
Ottawa, Ontario, Canada, K1P 6B9
Tel: 613.723.7035
Fax: 613.723.1518
Toll Free: 1.888.33.DYNEX (39639)

CUSTOMER SERVICE CENTRES

Mainland Europe Tel: +33 (0)1 58 04 91 00. Fax: +33 (0)1 46 38 51 33
North America Tel: (613) 723-7035. Fax: (613) 723-1518.
UK, Scandinavia & Rest Of World Tel: +44 (0)1522 500500. Fax: +44 (0)1522 500020

SALES OFFICES

Mainland Europe Tel: +33 (0)1 58 04 91 00. Fax: +33 (0)1 46 38 51 33
North America Tel: (613) 723-7035. Fax: (613) 723-1518. Toll Free: 1.888.33.DYNEX (39639) /
Tel: (949) 733-3005. Fax: (949) 733-2986.
UK, Scandinavia & Rest Of World Tel: +44 (0)1522 500500. Fax: +44 (0)1522 500020

These offices are supported by Representatives and Distributors in many countries world-wide.
© Dynex Semiconductor 2001 Publication No. DS5408-2 Issue No. 2.0 October 2001
TECHNICAL DOCUMENTATION – NOT FOR RESALE. PRINTED IN UNITED KINGDOM

Datasheet Annotations:

Dynex Semiconductor annotate datasheets in the top right hand corner of the front page, to indicate product status. The annotations are as follows:-

Target Information: This is the most tentative form of information and represents a very preliminary specification. No actual design work on the product has been started.

Preliminary Information: The product is in design and development. The datasheet represents the product as it is understood but details may change.

Advance Information: The product design is complete and final characterisation for volume production is well in hand.

No Annotation: The product parameters are fixed and the product is available to datasheet specification.

This publication is issued to provide information only which (unless agreed by the Company in writing) may not be used, applied or reproduced for any purpose nor form part of any order or contract nor to be regarded as a representation relating to the products or services concerned. No warranty or guarantee express or implied is made regarding the capability, performance or suitability of any product or service. The Company reserves the right to alter without prior notice the specification, design or price of any product or service. Information concerning possible methods of use is provided as a guide only and does not constitute any guarantee that such methods of use will be satisfactory in a specific piece of equipment. It is the user's responsibility to fully determine the performance and suitability of any equipment using such information and to ensure that any publication or data used is up to date and has not been superseded. These products are not suitable for use in any medical products whose failure to perform may result in significant injury or death to the user. All products and materials are sold and services provided subject to the Company's conditions of sale, which are available on request.

All brand names and product names used in this publication are trademarks, registered trademarks or trade names of their respective owners.