



REG5601

18-LINE SCSI ACTIVE TERMINATOR

FEATURES

- COMPLIES WITH SCSI-2 SPECIFICATIONS
- INTERNAL 2.9V REGULATOR
- ON-CHIP TERMINATION RESISTORS
- DISCONNECT ALL TERMINATION RESISTORS WITH A SINGLE LOGIC COMMAND
- POWER-DOWN MODE: 150 μ A max
- LINE CAPACITANCE: 10pF typ
- CURRENT LIMIT AND THERMAL SHUT-DOWN PROTECTION
- 28-Lead SOIC and SSOP PACKAGES

DESCRIPTION

The REG5601 is an 18-line active terminator for SCSI-2 (Small Computer Systems Interface) circuitry. On-chip resistors and 2.9V regulator provide the prescribed 110 Ω termination for low power dissipation and high speed data transmission.

All line connections can be disconnected from the bus with a single logic control line to reduce standby power consumption. Output lines remain high impedance without power applied. Each line is individually clamped at ground to dissipate negative-going glitches. The 2.9V regulator is current-limited and thermally protected. Regulated output is available for external circuitry.

The REG5601 is available in 28-lead SOIC and fine-pitch SSOP packages and is specified for operation over the 0 $^{\circ}$ C to 70 $^{\circ}$ C temperature range.

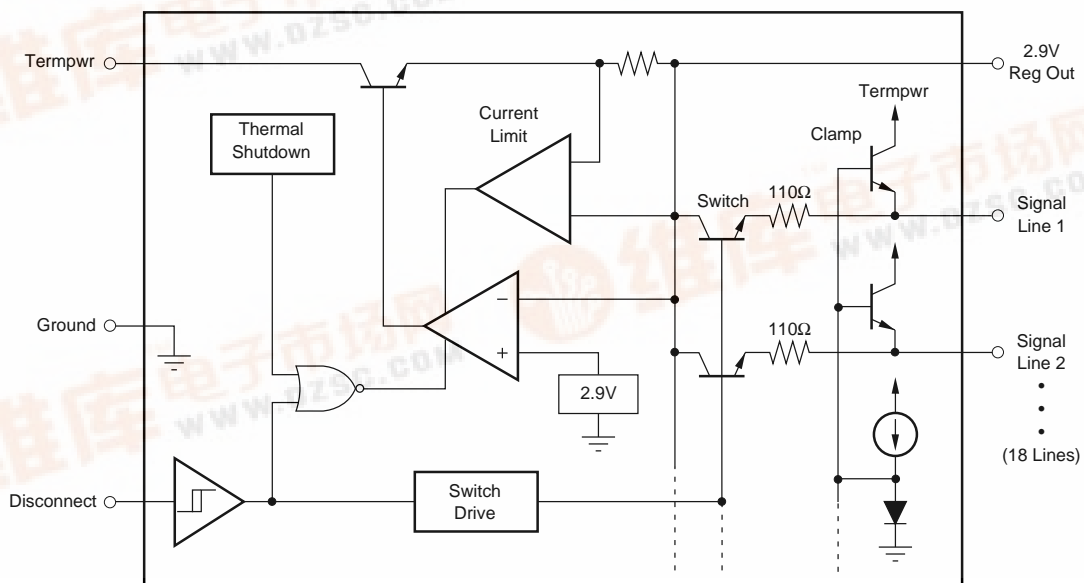

SPECIFICATIONS

T_A = 0°C to +70°C, Tempwpr = 4.75V, and Disconnect = 0V unless otherwise specified.

PARAMETERS	CONDITIONS	REG5601U			REG5601E			UNIT
		MIN	TYP	MAX	MIN	TYP	MAX	
POWER SUPPLY								
Tempwpr Supply Voltage	All Termination Lines = Open All V _{TERM} = 0.5V Disconnect = Open (High)	4.0		5.25	4.0		5.25	V
Tempwpr Supply Current			14	25		14	25	mA
Power-Down Mode				385	430		385	430
			100	150		100	150	µA
TERMINATION LINES								
Termination Impedance	$\Delta I_{TERM} = 5mA$ to 15mA Tempwpr = 4V ⁽¹⁾ V _{TERM} = 0.5V Tempwpr = 4V, V _{TERM} = 0.5V ⁽¹⁾ I _{TERM} = -30mA Disconnect = Open (High), Tempwpr = 0V to 5.25V Disconnect = Open (High)	107	110	115	107	110	115.5	Ω
Output High Voltage		2.65	2.8		2.65	2.8		V
Maximum Output Current		20.5	21.7	22.4	19.8	21.7	22.4	mA
		19.4	21	22.4	19	21	22.4	mA
Output Clamp Level		-0.2	-0.05	0.1	-0.2	-0.05	0.1	V
Output Leakage		20		400	20		400	nA
Output Capacitance		10			10		pF	
REGULATOR								
Regulator Output Voltage	Tempwpr = 4V to 6V I _{REG} = 0 to 400mA All V _{TERM} = 0.5V, $\Delta V_{REG} = 100mV$ V _{REG} = 0V V _{REG} = 3.5V	2.8	2.9	3.0	2.8	2.9	3.0	V
Line Regulation			6	20		6	20	mV
Load Regulation			20	50		20	50	mV
Drop-Out Voltage			1.0	1.2		1.0	1.2	V
Short-Circuit Current		450	1350	1650	450	1350	1650	mA
Current Sink		8	11		8	11		mA
Thermal Shutdown			170			170		°C
DISCONNECT LOGIC INPUT								
Disconnect Threshold	Disconnect = 0V	0.8	1.6	2.0	0.8	1.6	2.0	V
Threshold Hysteresis			200			200		mV
Input Current (Internal Pull-Up)			6	15		6	15	µA
TEMPERATURE RANGE								
Operating		0		70	0		70	°C
Storage		-40		150	-40		150	°C
θ _{JL} (junction to lead)			20			20		°C/W

NOTE: (1) Measurement of each termination line while the other 17 lines are held low (0.5V).

CONNECTION DIAGRAM

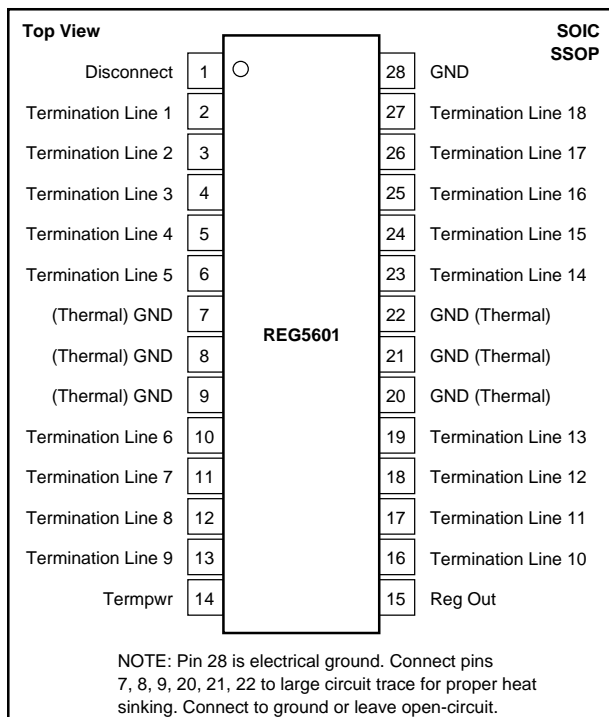

ABSOLUTE MAXIMUM RATINGS

Tempwpr Voltage	+7V
Signal Line Voltage	0V to +7V
Regulator Output Current	1.65A
Power Dissipation	2.5W
Operating Junction Temperature	-40°C to +150°C
Storage Temperature	-40°C to +150°C

PACKAGE/ORDERING INFORMATION

MODEL	PACKAGE	PACKAGE DRAWING NUMBER ⁽¹⁾
REG5601U	Plastic 28-Lead SOIC	217
REG5601E	Plastic 28-Lead SSOP	324

NOTE: (1) For detailed drawing and dimension table, please see end of data sheet, or Appendix D of Burr-Brown IC Data Book.

ELECTROSTATIC DISCHARGE SENSITIVITY

This integrated circuit can be damaged by ESD. Burr-Brown recommends that all integrated circuits be handled with appropriate precautions. Failure to observe proper handling and installation procedures can cause damage.

The information provided herein is believed to be reliable; however, BURR-BROWN assumes no responsibility for inaccuracies or omissions. BURR-BROWN assumes no responsibility for the use of this information, and all use of such information shall be entirely at the user's own risk. Prices and specifications are subject to change without notice. No patent rights or licenses to any of the circuits described herein are implied or granted to any third party. BURR-BROWN does not authorize or warrant any BURR-BROWN product for use in life support devices and/or systems.

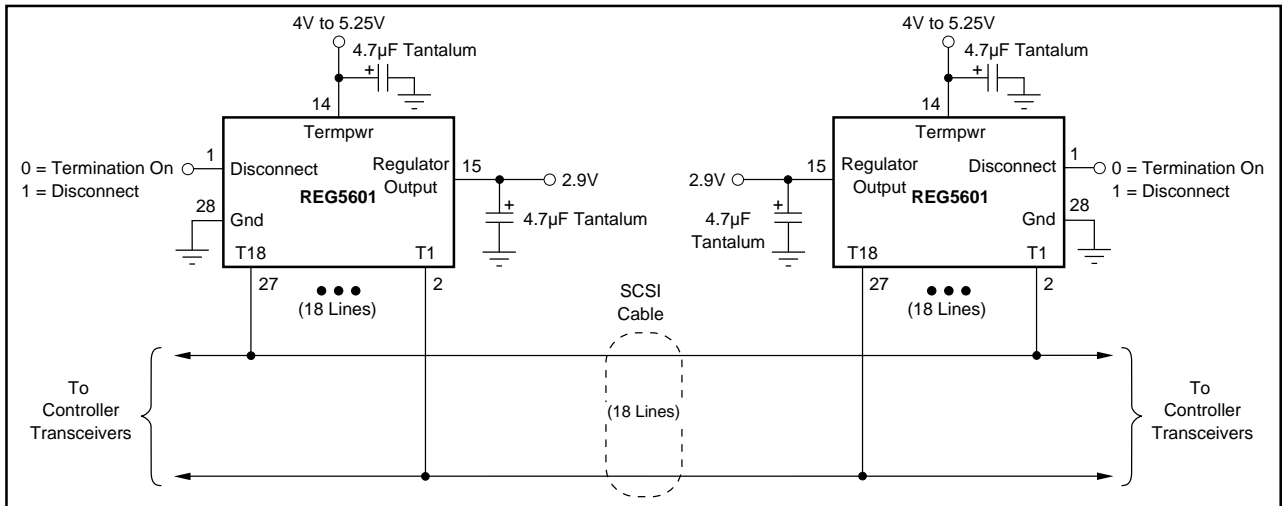

FIGURE 1. Standard SCSI Termination Application.

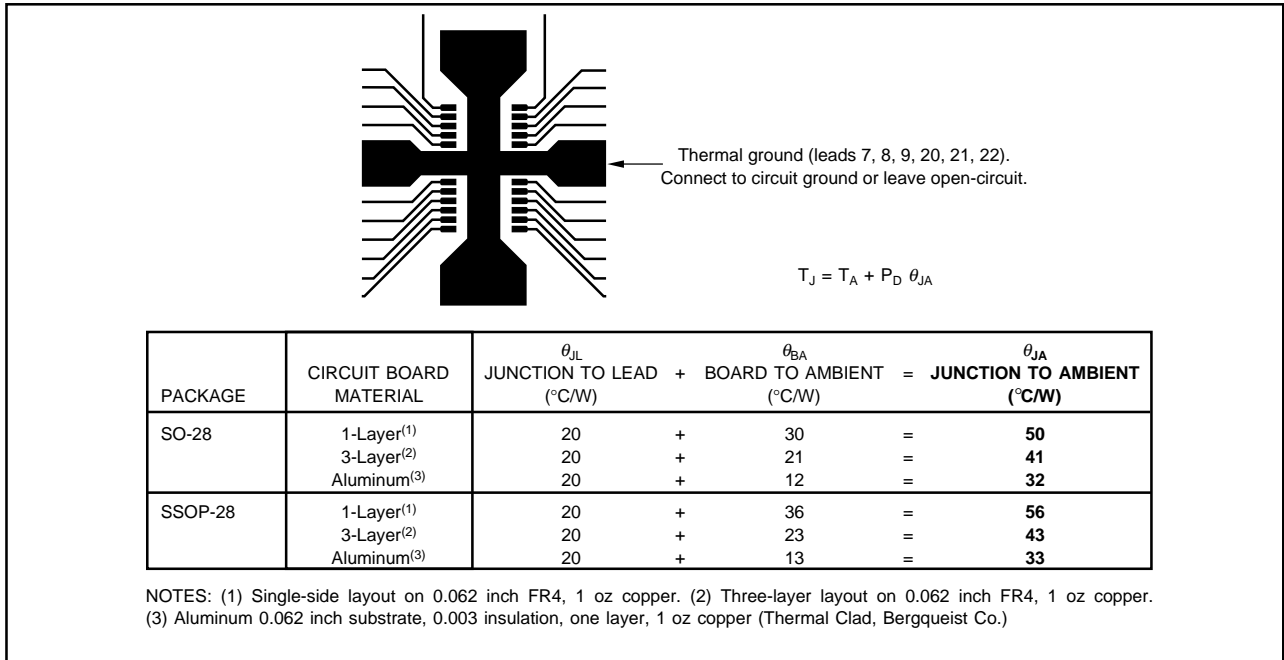

FIGURE 2. Circuit Board Layout.

The REG5601 has current limit and thermal shutdown that protect it from damage during output short-circuit or overload. The current limit is approximately 1350mA and thermal shutdown activates at a junction temperature of approximately 175°C. For good reliability, the junction temperature should not exceed 125°C. Any tendency to activate the thermal shutdown during normal operation is an indication of inadequate heat sinking and/or excessive power dissipation.

Heat is dissipated primarily by conduction through the leads to circuit board traces. It is important to connect the six thermal ground leads (7, 8, 9, 20, 21, 22) to a large circuit ground trace—see Figure 2. Measured values of thermal resistance for various circuit board materials are shown. These are approximate values. Variations in circuit board pattern, mounting techniques, air flow, proximity to other circuit boards and heat sources will affect thermal performance.

A simple experiment will determine whether the actual circuit board layout is adequate (i.e., θ_{BA} is low enough) so that the maximum recommended junction temperature of the REG5601 will not be exceeded. The procedure uses the internal thermal shutdown feature of the REG5601 (at $T_J \approx 175^\circ\text{C}$) to determine when the junction is approximately 50°C above the maximum recommended junction temperature ($T_J = 125^\circ\text{C}$). Operate the circuit with normal or other desired test electrical conditions. Increase the ambient temperature and determine the value at which thermal limit occurs (by sensing a sudden drop in V_{REG} output). At this point T_J is approximately 175°C. If this occurs at an ambient temperature of more than 50°C above the system ambient temperature design goal, the T_J will not exceed 125°C under the same electrical conditions when the ambient temperature is at the system design goal value.