

### 45A, 60V, 0.028 Ohm, Logic Level N-Channel Power MOSFETs

These are N-Channel enhancement mode power MOSFETs manufactured using the latest manufacturing process technology. This process, which uses feature sizes approaching those of LSI circuits, gives optimum utilization of silicon, resulting in outstanding performance. They were designed for use in applications such as switching regulators, switching converters, motor drivers, and relay drivers. These transistors can be operated directly from integrated circuits.

Formerly developmental type TA49177.

### Ordering Information

PART NUMBER	PACKAGE	BRAND
RFP45N06LE	TO-220AB	FP45N06L
RF1S45N06LESM	TO-263AB	F45N06LE

NOTE: When ordering, use the entire part number. Add the suffix 9A to obtain the TO-263AB variant in tape and reel i.e., RF1S45N06LESM9A.

### Features

- 45A, 60V
- $r_{DS(ON)} = 0.028\Omega$
- Temperature Compensating PSPICE<sup>®</sup> Model
- Peak Current vs Pulse Width Curve
- UIS Rating Curve
- 175°C Operating Temperature
- Related Literature
  - TB334 "Guidelines for Soldering Surface Mount Components to PC Boards"

### Symbol

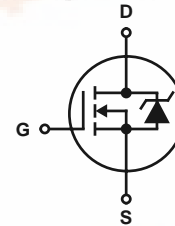

### Packaging

JEDEC TO-220AB

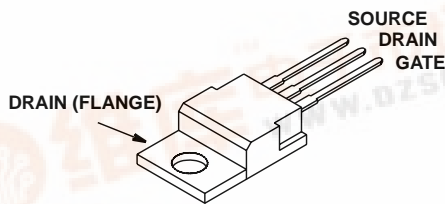

JEDEC TO-263AB

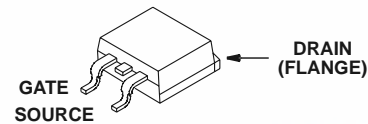

## RFP45N06LE, RF1S45N06LESM

### Absolute Maximum Ratings $T_C = 25^\circ\text{C}$ , Unless Otherwise Specified

	RFP45N06LE, RF1S45N06LESM	UNITS
Drain to Source Voltage (Note 1) . . . . .	60	V
Drain to Gate Voltage ( $R_{GS} = 20\text{k}\Omega$ ) (Note 1) . . . . .	60	V
Gate to Source Voltage . . . . .	$\pm 10$	V
Continuous Drain Current . . . . .	45	A
Pulsed Drain Current (Note 3) . . . . .	Refer to Peak Current Curve	
Pulsed Avalanche Rating . . . . .	Refer to UIS Curve	
Power Dissipation . . . . .	142	W
Derate Above $25^\circ\text{C}$ . . . . .	0.95	$\text{W}/^\circ\text{C}$
Operating and Storage Temperature . . . . .	-55 to 175	$^\circ\text{C}$
Maximum Temperature for Soldering		
Leads at 0.063in (1.6mm) from Case for 10s . . . . .	300	$^\circ\text{C}$
Package Body for 10s, See Techbrief 334 . . . . .	260	$^\circ\text{C}$

*CAUTION: Stresses above those listed in "Absolute Maximum Ratings" may cause permanent damage to the device. This is a stress only rating and operation of the device at these or any other conditions above those indicated in the operational sections of this specification is not implied.*

**NOTE:**

1.  $T_J = 25^\circ\text{C}$  to  $150^\circ\text{C}$ .

### Electrical Specifications $T_C = 25^\circ\text{C}$ , Unless Otherwise Specified

PARAMETER	SYMBOL	TEST CONDITIONS	MIN	TYP	MAX	UNITS
Drain to Source Breakdown Voltage	$BV_{DSS}$	$I_D = 250\mu\text{A}$ , $V_{GS} = 0\text{V}$ (Figure 13)	60	-	-	V
Gate Threshold Voltage	$V_{GS(TH)}$	$V_{GS} = V_{DS}$ , $I_D = 250\mu\text{A}$ (Figure 12)	1	-	3	V
Zero Gate Voltage Drain Current	$I_{DSS}$	$V_{DS} = 55\text{V}$ , $V_{GS} = 0\text{V}$	-	-	1	$\mu\text{A}$
		$V_{DS} = 50\text{V}$ , $V_{GS} = 0\text{V}$ , $T_C = 150^\circ\text{C}$	-	-	250	$\mu\text{A}$
Gate to Source Leakage Current	$I_{GSS}$	$V_{GS} = \pm 10\text{V}$	-	-	10	$\mu\text{A}$
Drain to Source On Resistance (Note 2)	$r_{DS(ON)}$	$I_D = 45\text{A}$ , $V_{GS} = 5\text{V}$ (Figure 11)	-	-	0.028	$\Omega$
Turn-On Time	$t_{ON}$	$V_{DD} = 30\text{V}$ , $I_D = 45\text{A}$ , $R_L = 0.67\Omega$ , $V_{GS} = 5\text{V}$ , $R_{GS} = 2.5\Omega$ (Figures 10, 18, 19)	-	-	215	ns
Turn-On Delay Time	$t_{d(ON)}$		-	20	-	ns
Rise Time	$t_r$		-	150	-	ns
Turn-Off Delay Time	$t_{d(OFF)}$		-	55	-	ns
Fall Time	$t_f$		-	90	-	ns
Turn-Off Time	$t_{OFF}$		-	-	-	185
Total Gate Charge	$Q_{g(TOT)}$	$V_{GS} = 0\text{V}$ to $10\text{V}$	-	107	135	nC
Gate Charge at 5V	$Q_{g(5)}$	$V_{GS} = 0\text{V}$ to $5\text{V}$				
Threshold Gate Charge	$Q_{g(TH)}$	$V_{GS} = 0\text{V}$ to $1\text{V}$				
Input Capacitance	$C_{ISS}$	$V_{DS} = 25\text{V}$ , $V_{GS} = 0\text{V}$ , $f = 1\text{MHz}$ (Figure 14)	-	2150	-	pF
Output Capacitance	$C_{OSS}$		-	640	-	pF
Reverse Transfer Capacitance	$C_{RSS}$		-	240	-	pF
Thermal Resistance Junction to Case	$R_{\theta JC}$		-	-	1.05	$^\circ\text{C}/\text{W}$
Thermal Resistance Junction to Ambient	$R_{\theta JA}$	TO-220, and TO-263	-	-	80	$^\circ\text{C}/\text{W}$

### Source to Drain Diode Specifications

PARAMETER	SYMBOL	TEST CONDITIONS	MIN	TYP	MAX	UNITS
Source to Drain Diode Voltage	$V_{SD}$	$I_{SD} = 45\text{A}$	-	-	1.5	V
Diode Reverse Recovery Time	$t_{rr}$	$I_{SD} = 45\text{A}$ , $dI_{SD}/dt = 100\text{A}/\mu\text{s}$	-	-	155	ns

**NOTES:**

2. Pulse test: pulse width  $\leq 80\mu\text{s}$ , duty cycle  $\leq 2\%$ .
3. Repetitive rating: pulse width limited by Max junction temperature. See Transient Thermal Impedance curve (Figure 3).

# RFP45N06LE, RF1S45N06LESM

## Typical Performance Curves Unless Otherwise Specified

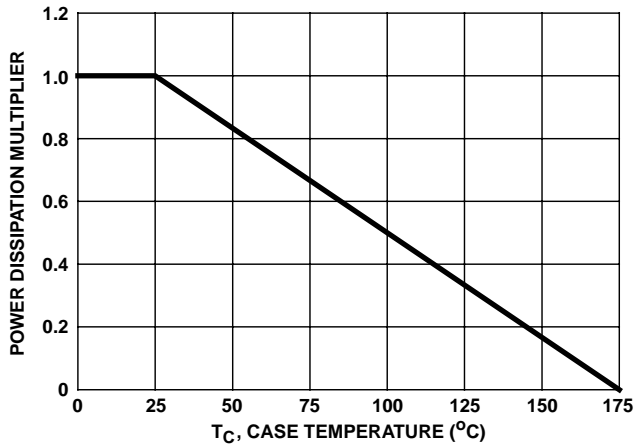

FIGURE 1. NORMALIZED POWER DISSIPATION vs CASE TEMPERATURE

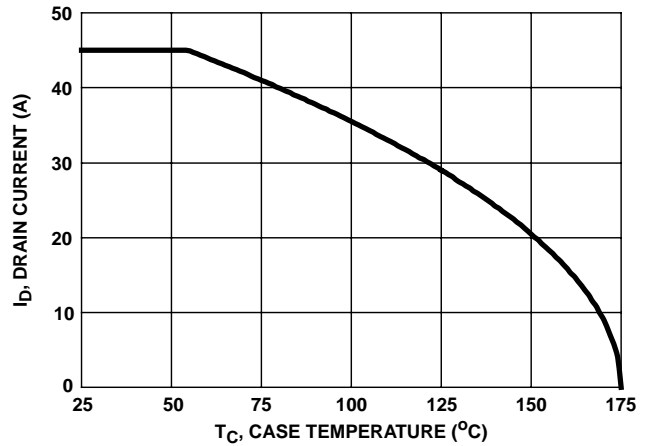

FIGURE 2. MAXIMUM CONTINUOUS DRAIN CURRENT vs CASE TEMPERATURE

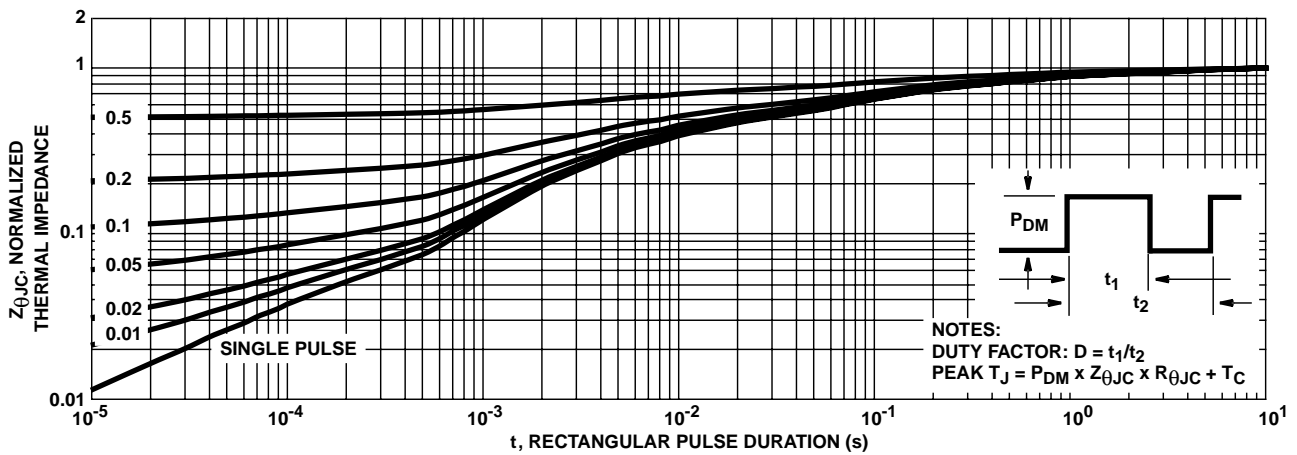

FIGURE 3. NORMALIZED MAXIMUM TRANSIENT THERMAL IMPEDANCE

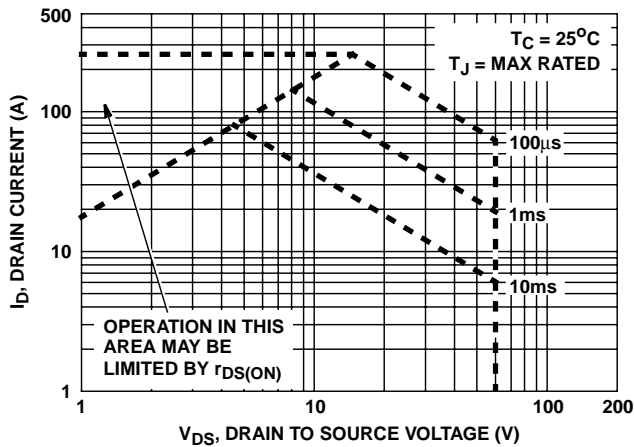

FIGURE 4. FORWARD BIAS SAFE OPERATING AREA

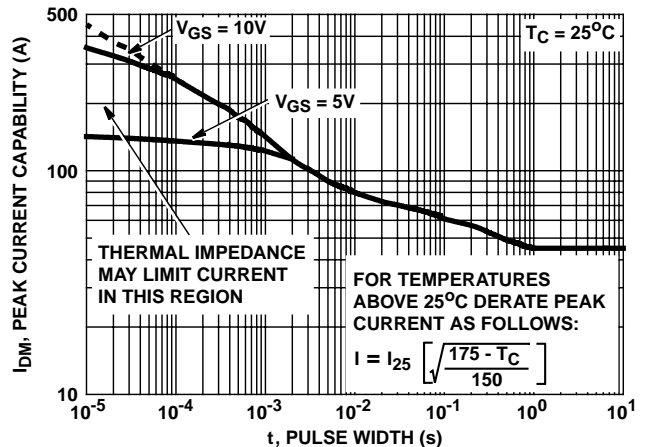
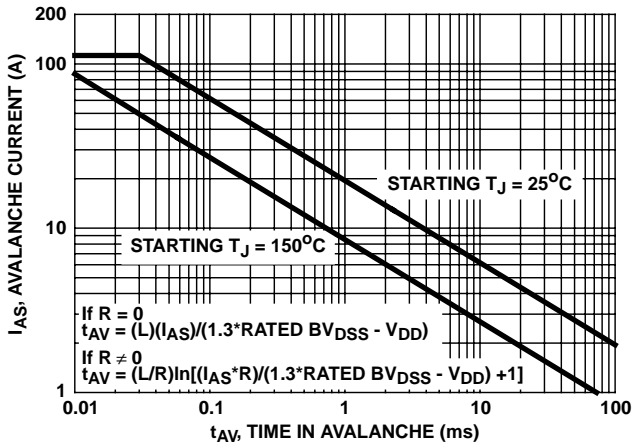

FIGURE 5. PEAK CURRENT CAPABILITY

# RFP45N06LE, RF1S45N06LESM

## Typical Performance Curves Unless Otherwise Specified (Continued)



NOTE: Refer to Intersil Application Notes AN9321 and AN9322.

FIGURE 6. UNCLAMPED INDUCTIVE SWITCHING

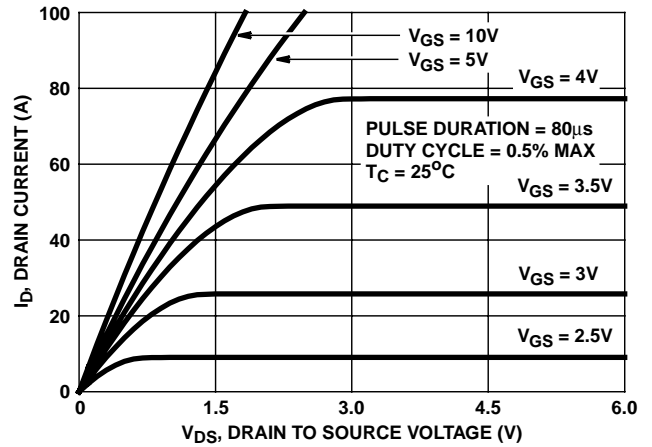

FIGURE 7. SATURATION CHARACTERISTICS

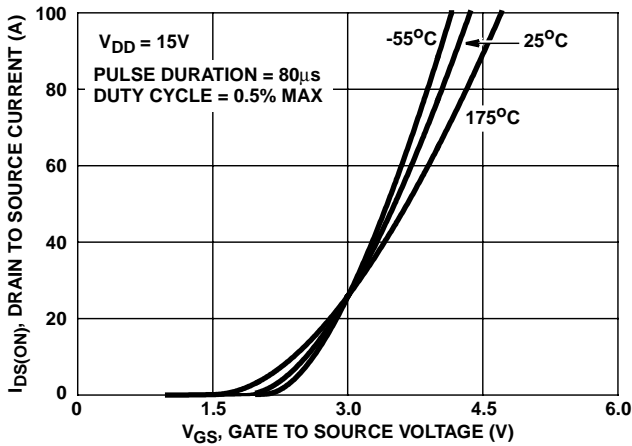

FIGURE 8. TRANSFER CHARACTERISTICS

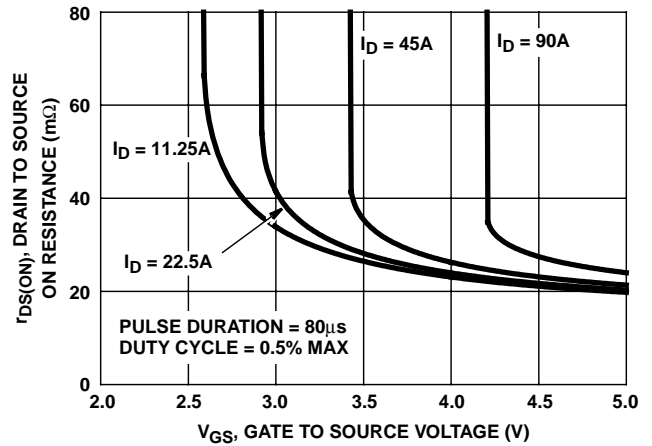

FIGURE 9. DRAIN TO SOURCE ON RESISTANCE vs GATE VOLTAGE AND DRAIN CURRENT

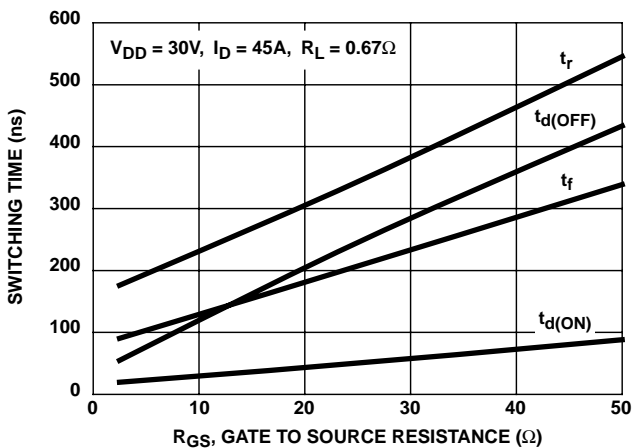

FIGURE 10. SWITCHING TIME vs GATE RESISTANCE

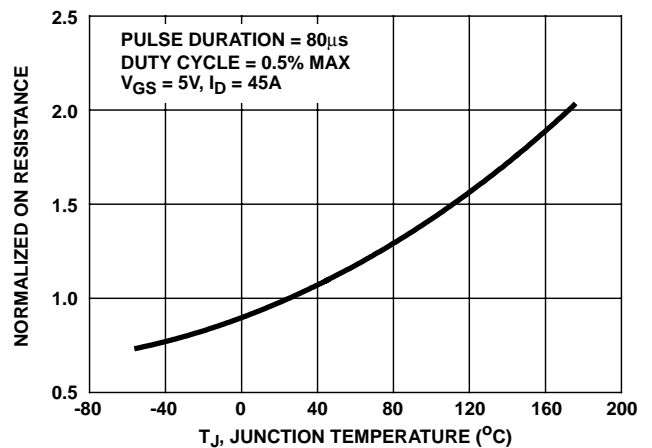

FIGURE 11. NORMALIZED DRAIN TO SOURCE ON RESISTANCE vs JUNCTION TEMPERATURE

## RFP45N06LE, RF1S45N06LESM

### Typical Performance Curves Unless Otherwise Specified (Continued)

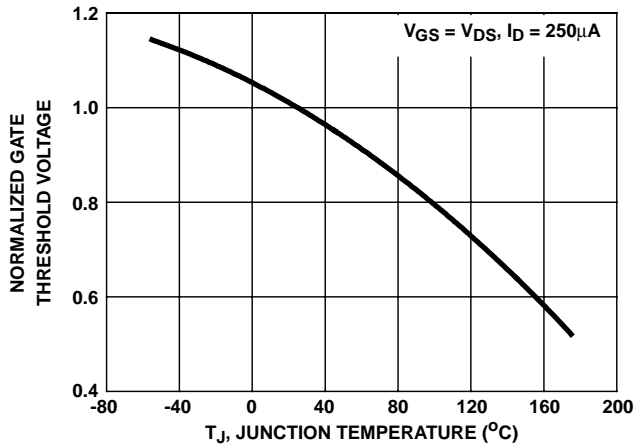

FIGURE 12. NORMALIZED GATE THRESHOLD VOLTAGE vs JUNCTION TEMPERATURE

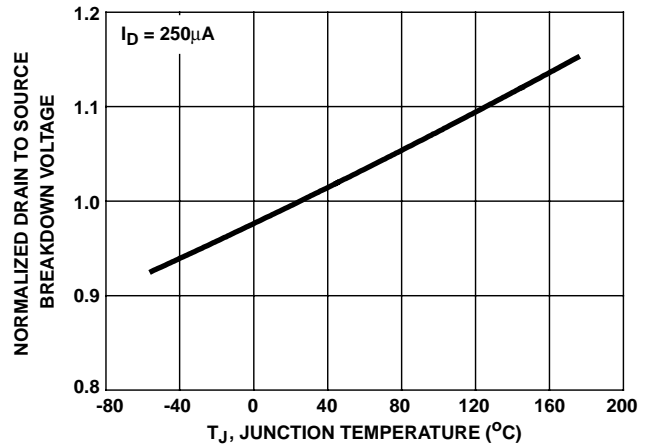

FIGURE 13. NORMALIZED DRAIN TO SOURCE BREAKDOWN VOLTAGE vs JUNCTION TEMPERATURE

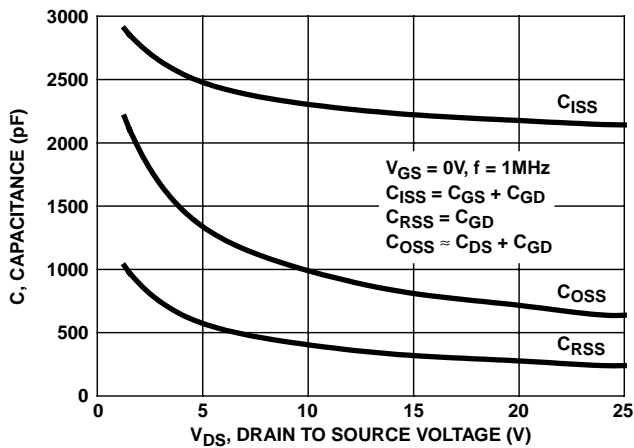
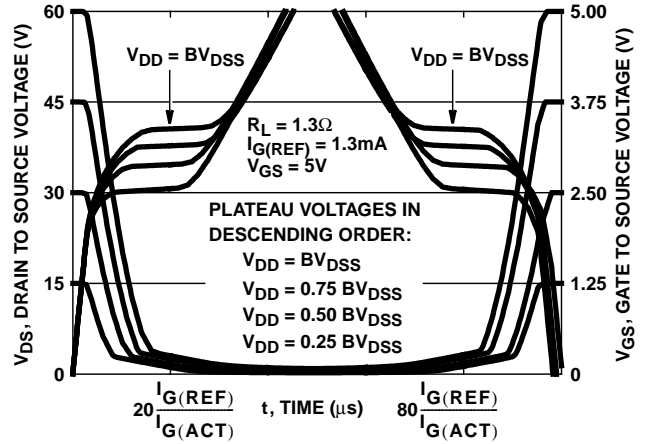

FIGURE 14. CAPACITANCE vs DRAIN TO SOURCE VOLTAGE



NOTE: Refer to Intersil Application Notes AN7254 and AN7260.

FIGURE 15. NORMALIZED SWITCHING WAVEFORMS FOR CONSTANT GATE CURRENT

### Test Circuits and Waveforms

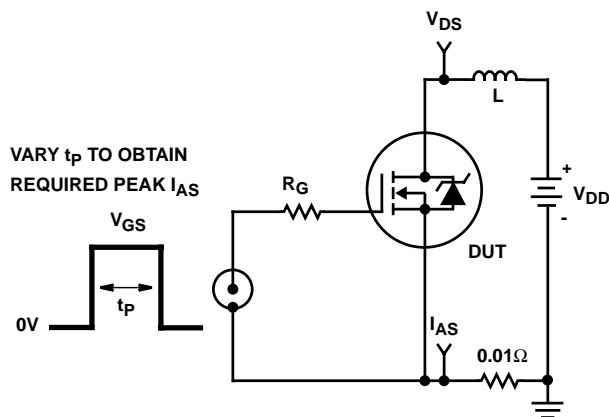

FIGURE 16. UNCLAMPED ENERGY TEST CIRCUIT

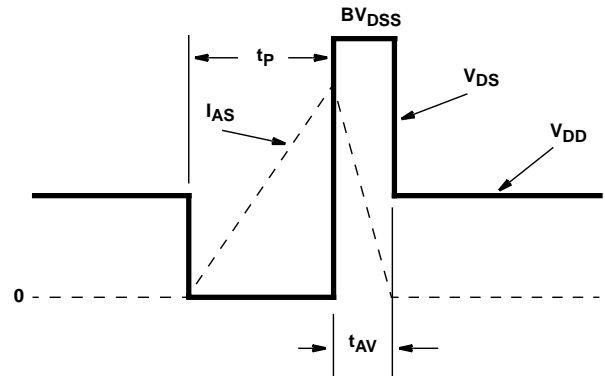

FIGURE 17. UNCLAMPED ENERGY WAVEFORMS

Test Circuits and Waveforms (Continued)

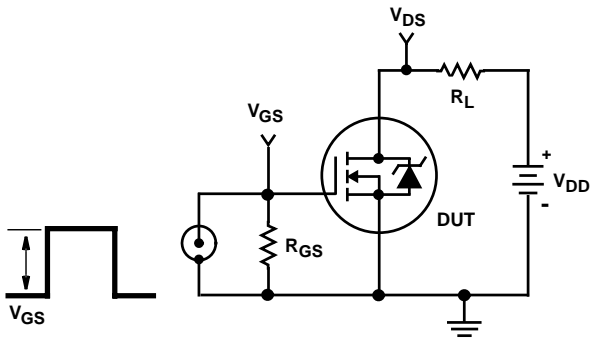

FIGURE 18. SWITCHING TIME TEST CIRCUIT

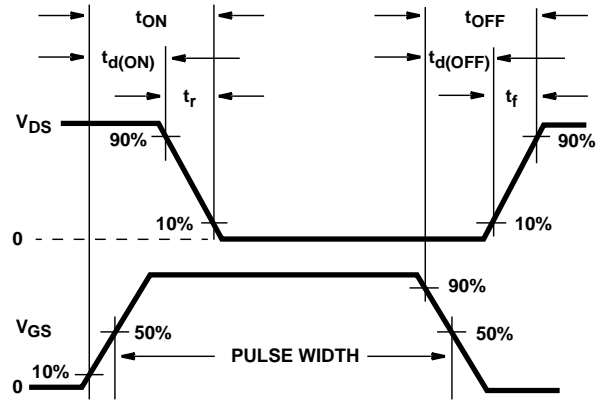

FIGURE 19. RESISTIVE SWITCHING WAVEFORMS

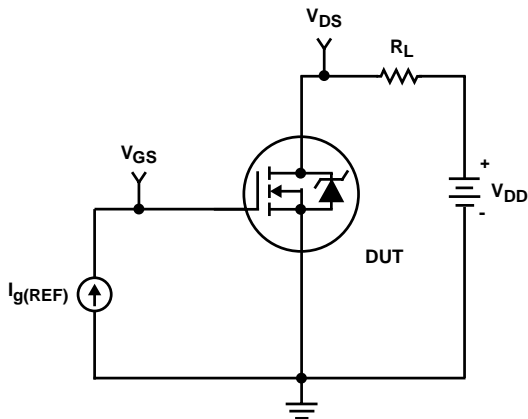

FIGURE 20. GATE CHARGE TEST CIRCUIT

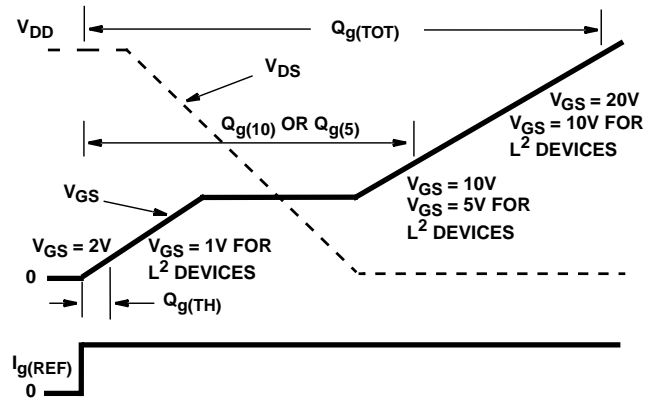

FIGURE 21. GATE CHARGE WAVEFORMS

# RFP45N06LE, RF1S45N06LESM

## PSPICE Electrical Model

SUBCKT 45N06LE 2 1 3 ; rev 10/25/95

CA 12 8 3.73e-9  
 CB 15 14 3.73e-9  
 CIN 6 8 2.08e-9

DBODY 7 5 DBODYMOD  
 DBREAK 5 11 DBREAKMOD  
 DPLCAP 10 5 DPLCAPMOD

EBREAK 11 7 17 18 66.5  
 EDS 14 8 5 8 1  
 EGS 13 8 6 8 1  
 ESG 6 10 6 8 1  
 EVTHRES 6 21 19 8 1  
 EVTEMP 20 6 18 22 1

IT 8 17 1

LDRAIN 2 5 4.0e-9  
 LGATE 1 9 6.0e-9  
 LSOURCE 3 7 3.0e-9

MMED 16 6 8 8 MMEDMOD  
 MSTRO 16 6 8 8 MSTROMOD  
 MWEAK 16 21 8 8 MWEAKMOD

RBREAK 17 18 RBREAKMOD 1  
 RDRAIN 50 16 RDRAINMOD 3.75e-3  
 RGATE 9 20 1.0  
 RLDRAIN 2 5 40  
 RLGATE 1 9 60  
 RLSOURCE 3 7 30  
 RSLC1 5 51 RSLCMOD 1e-6  
 RSLC2 5 50 1e3  
 RSOURCE 8 7 RSOURCEMOD 6.15e-3  
 RVTHRES 22 8 RVTHRESMOD 1  
 RVTEMP 18 19 RVTEMPMOD 1

S1A 6 12 13 8 S1AMOD  
 S1B 13 12 13 8 S1BMOD  
 S2A 6 15 14 13 S2AMOD  
 S2B 13 15 14 13 S2BMOD

VBAT 22 19 DC 1

ESLC 51 50 VALUE={(V(5,51)/ABS(V(5,51)))\*(PWR(V(5,51)/(1e-6\*200),4))}

.MODEL DBODYMOD D (IS = 1.70e-12 RS = 3.20e-3 TRS1 = 1.75e-3 TRS2 = 1.75e-6 CJO = 2.55e-9 IKF = 13 XTI = 5.2 TT = 7.00e-8 M = 0.47)  
 .MODEL DBREAKMOD D (RS = 1.70e-1 IKF = 0.1 TRS1 = 2.00e-3 TRS2 = 8.00e-7)  
 .MODEL DPLCAPMOD D (CJO = 2.00e-9 IS = 1e-30 VJ = 1.1 M = 0.83 N = 10)  
 .MODEL MMEDMOD NMOS (VTO = 2.00 KP = 5 IS = 1e-30 N = 10 TOX = 1 L = 1u W = 1u RG = 1.0)  
 .MODEL MSTROMOD NMOS (VTO = 2.42 KP = 128 IS = 1e-30 N = 10 TOX = 1 L = 1u W = 1u)  
 .MODEL MWEAKMOD NMOS (VTO = 1.60 KP = 0.01 IS = 1e-30 N = 10 TOX = 1 L = 1u W = 1u RG = 10.0 RS = 0.1)  
 .MODEL RBREAKMOD RES (TC1 = 1.13e-3 TC2 = 0)  
 .MODEL RDRAINMOD RES (TC1 = 1.20e-2 TC2 = 6.00e-5)  
 .MODEL RSLCMOD RES (TC1 = 2.00e-3 TC2 = 1.00e-6)  
 .MODEL RSOURCEMOD RES (TC1 = 2.00e-3 TC2 = -1.00e-5)  
 .MODEL RVTHRESMOD RES (TC1 = -2.50e-3 TC2 = -8.50e-6)  
 .MODEL RVTEMPMOD RES (TC1 = -2.00e-3 TC2 = 5.00e-6)  
 .MODEL S1AMOD VSWITCH (RON = 1e-5 ROFF = 0.1 VON = -5.3 VOFF = -2.5)  
 .MODEL S1BMOD VSWITCH (RON = 1e-5 ROFF = 0.1 VON = -2.5 VOFF = -5.3)  
 .MODEL S2AMOD VSWITCH (RON = 1e-5 ROFF = 0.1 VON = -1.4 VOFF = 0.5)  
 .MODEL S2BMOD VSWITCH (RON = 1e-5 ROFF = 0.1 VON = 0.5 VOFF = -1.4)

.ENDS

NOTE: For further discussion of the PSPICE model, consult **A New PSPICE Sub-Circuit for the Power MOSFET Featuring Global Temperature Options**; IEEE Power Electronics Specialist Conference Records, 1991, written by William J. Hepp and C. Frank Wheatley.

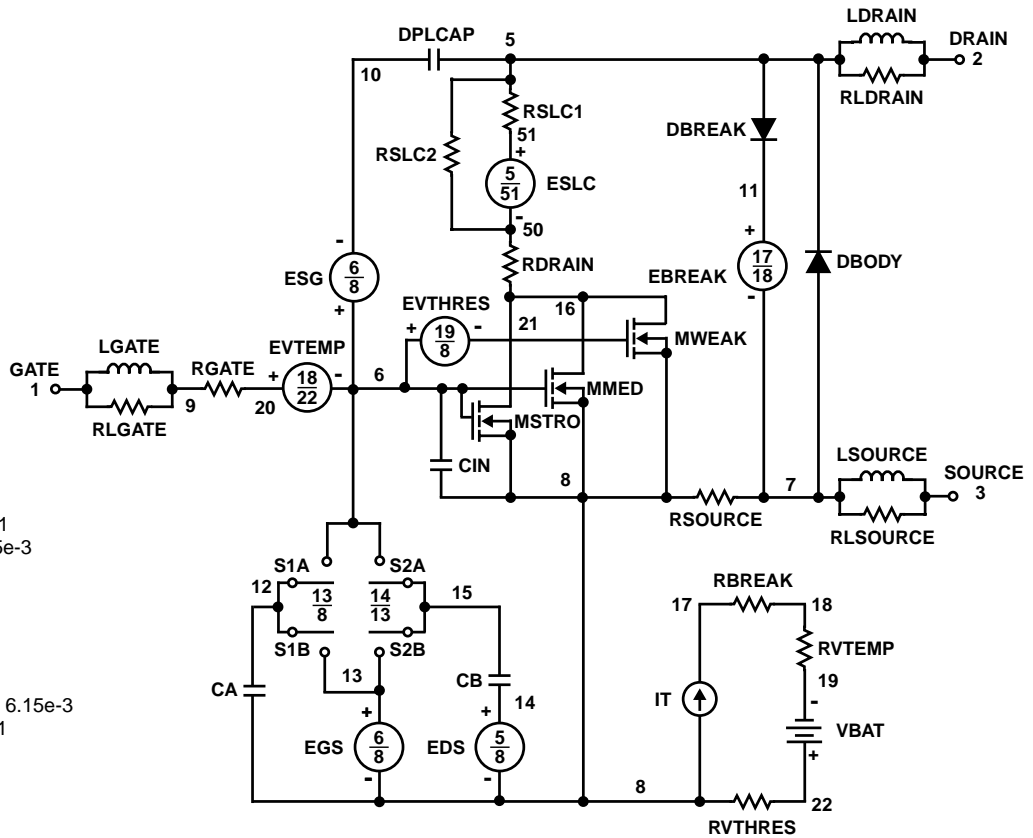

## RFP45N06LE, RF1S45N06LESM

---

All Intersil semiconductor products are manufactured, assembled and tested under **ISO9000** quality systems certification.

*Intersil semiconductor products are sold by description only. Intersil Corporation reserves the right to make changes in circuit design and/or specifications at any time without notice. Accordingly, the reader is cautioned to verify that data sheets are current before placing orders. Information furnished by Intersil is believed to be accurate and reliable. However, no responsibility is assumed by Intersil or its subsidiaries for its use; nor for any infringements of patents or other rights of third parties which may result from its use. No license is granted by implication or otherwise under any patent or patent rights of Intersil or its subsidiaries.*

For information regarding Intersil Corporation and its products, see web site <http://www.intersil.com>

### **Sales Office Headquarters**

#### **NORTH AMERICA**

Intersil Corporation  
P. O. Box 883, Mail Stop 53-204  
Melbourne, FL 32902  
TEL: (407) 724-7000  
FAX: (407) 724-7240

#### **EUROPE**

Intersil SA  
Mercure Center  
100, Rue de la Fusee  
1130 Brussels, Belgium  
TEL: (32) 2.724.2111  
FAX: (32) 2.724.22.05

#### **ASIA**

Intersil (Taiwan) Ltd.  
7F-6, No. 101 Fu Hsing North Road  
Taipei, Taiwan  
Republic of China  
TEL: (886) 2 2716 9310  
FAX: (886) 2 2715 3029