

15A, 60V, 0.065 Ohm, ESD Rated, Logic Level, N-Channel Power MOSFETs

These are N-Channel power MOSFETs manufactured using the MegaFET process. This process, which uses feature sizes approaching those of LSI circuits, gives optimum utilization of silicon, resulting in outstanding performance. They were designed for use in applications such as switching regulators, switching converters, motor drivers, and relay drivers. These transistors can be operated directly from integrated circuits.

Formerly developmental type TA49165.

Ordering Information

PART NUMBER	PACKAGE	BRAND
RFD15N06LE	TO-251AA	F15N6L
RFD15N06LESM	TO-252AA	F15N6L

NOTE: When ordering, use the entire part number. For ordering in tape and reel, add the suffix 9A to the part number, i.e. RFD15N06LESM9A.

Features

- 15A, 60V
- $r_{DS(ON)} = 0.065\Omega$
- 2kV ESD Protected
- Temperature Compensating PSPICE™ Model
- Peak Current vs Pulse Width Curve
- UIS Rating Curve
- 175°C Operating Temperature
- Related Literature
 - TB334 "Guidelines for Soldering Surface Mount Components to PC Boards"

Symbol

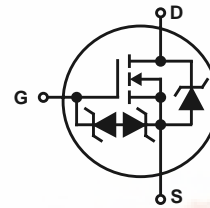

Packaging

JEDEC TO-251AA

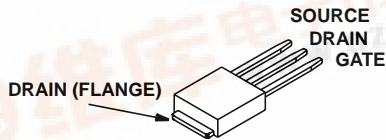

JEDEC TO-252AA

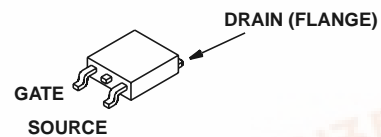

RFD15N06LE, RFD15N06LESM

Absolute Maximum Ratings $T_C = 25^\circ\text{C}$, Unless Otherwise Specified

	RFD15N06LE, RFD15N06LESM	UNITS
Drain to Source Voltage (Note 1)	60	V
Drain to Gate Voltage ($R_{GS} = 20\text{k}\Omega$) (Note 1)	60	V
Gate to Source Voltage	± 10	V
Continuous Drain Current	15	A
Pulsed Drain Current (Note 3)	Refer to Peak Current Curve	
Pulsed Avalanche Rating	Refer to UIS Curve	
Power Dissipation	72	W
Derate above 25°C	0.48	W/ $^\circ\text{C}$
Operating and Storage Temperature	-55 to 175	$^\circ\text{C}$
Electrostatic Discharge Rating MIL-STD-883, Category B(2)	2	kV
Maximum Temperature for Soldering		
Leads at 0.063in (1.6mm) from Case for 10s.	300	$^\circ\text{C}$
Package Body for 10s, See Techbrief 334	260	$^\circ\text{C}$

CAUTION: Stresses above those listed in "Absolute Maximum Ratings" may cause permanent damage to the device. This is a stress only rating and operation of the device at these or any other conditions above those indicated in the operational sections of this specification is not implied.

NOTE:

1. $T_J = 25^\circ\text{C}$ to 150°C .

Electrical Specifications $T_C = 25^\circ\text{C}$, Unless Otherwise Specified

PARAMETER	SYMBOL	TEST CONDITIONS	MIN	TYP	MAX	UNITS	
Drain to Source Breakdown Voltage	BV_{DSS}	$I_D = 250\mu\text{A}$, $V_{GS} = 0\text{V}$, Figure 13	60	-	-	V	
Gate Threshold Voltage	$V_{GS(TH)}$	$V_{GS} = V_{DS}$, $I_D = 250\mu\text{A}$, Figure 12	1	-	2	V	
Zero Gate Voltage Drain Current	I_{DSS}	$V_{DS} = 48\text{V}$, $V_{GS} = 0\text{V}$	$T_C = 25^\circ\text{C}$	-	-	1	μA
			$T_C = 150^\circ\text{C}$	-	-	50	μA
Gate to Source Leakage Current	I_{GSS}	$V_{GS} = \pm 10\text{V}$	-	-	10	μA	
Drain to Source On Resistance	$r_{DS(ON)}$	$I_D = 15\text{A}$, $V_{GS} = 5\text{V}$	-	-	0.065	Ω	
Turn-On Time	t_{ON}	$V_{DD} = 30\text{V}$, $I_D = 15\text{A}$, $R_L = 2.0\Omega$, $V_{GS} = 5\text{V}$, $R_{GS} = 2.5\Omega$ Figures 10, 18, 19	-	-	77	ns	
Turn-On Delay Time	$t_{d(ON)}$		-	11	-	ns	
Rise Time	t_r		-	40	-	ns	
Turn-Off Delay Time	$t_{d(OFF)}$		-	30	-	ns	
Fall Time	t_f		-	18	-	ns	
Turn-Off Time	t_{OFF}		-	-	-	75	ns
Total Gate Charge	$Q_g(TOT)$	$V_{GS} = 0\text{V}$ to 10V	-	39	49	nC	
Gate Charge at 5V	$Q_g(5)$	$V_{GS} = 0\text{V}$ to 5V					
Threshold Gate Charge	$Q_g(TH)$	$V_{GS} = 0\text{V}$ to 1V					
Input Capacitance	C_{ISS}	$V_{DS} = 25\text{V}$, $V_{GS} = 0\text{V}$, $f = 1\text{MHz}$ Figure 14	-	855	-	pF	
Output Capacitance	C_{OSS}		-	240	-	pF	
Reverse Transfer Capacitance	C_{RSS}		-	75	-	pF	
Thermal Resistance Junction to Case	$R_{\theta JC}$		-	-	2.08	$^\circ\text{C/W}$	
Thermal Resistance Junction to Ambient	$R_{\theta JA}$	TO-251 and TO-252	-	-	100	$^\circ\text{C/W}$	

Source to Drain Diode Specifications

PARAMETER	SYMBOL	TEST CONDITIONS	MIN	TYP	MAX	UNITS
Source to Drain Diode Voltage	V_{SD}	$I_{SD} = 15\text{A}$	-	-	1.5	V
Diode Reverse Recovery Time	t_{rr}	$I_{SD} = 15\text{A}$, $dI_{SD}/dt = 100\text{A}/\mu\text{s}$	-	-	80	ns

NOTES:

2. Pulse Test: Pulse Width $\leq 300\text{ms}$, Duty Cycle $\leq 2\%$.
3. Repetitive Rating: Pulse Width limited by max junction temperature. See Transient Thermal Impedance Curve (Figure 3) and Peak Current Capability Curve (Figure 5).

RFD15N06LE, RFD15N06LESM

Typical Performance Curves Unless Otherwise Specified

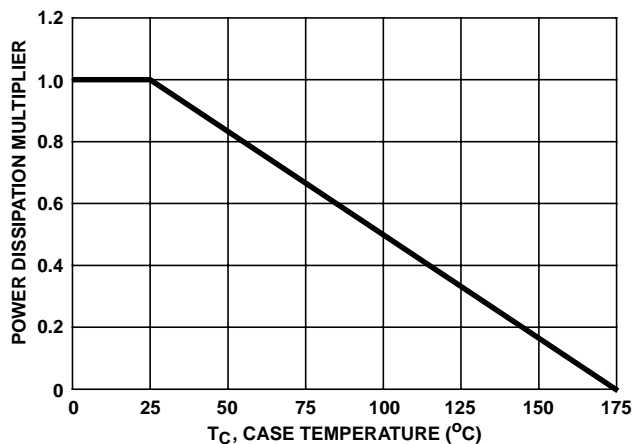

FIGURE 1. NORMALIZED POWER DISSIPATION vs CASE TEMPERATURE

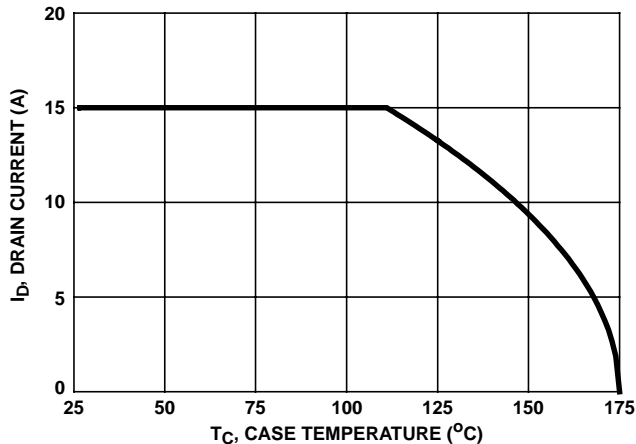

FIGURE 2. MAXIMUM CONTINUOUS DRAIN CURRENT vs CASE TEMPERATURE

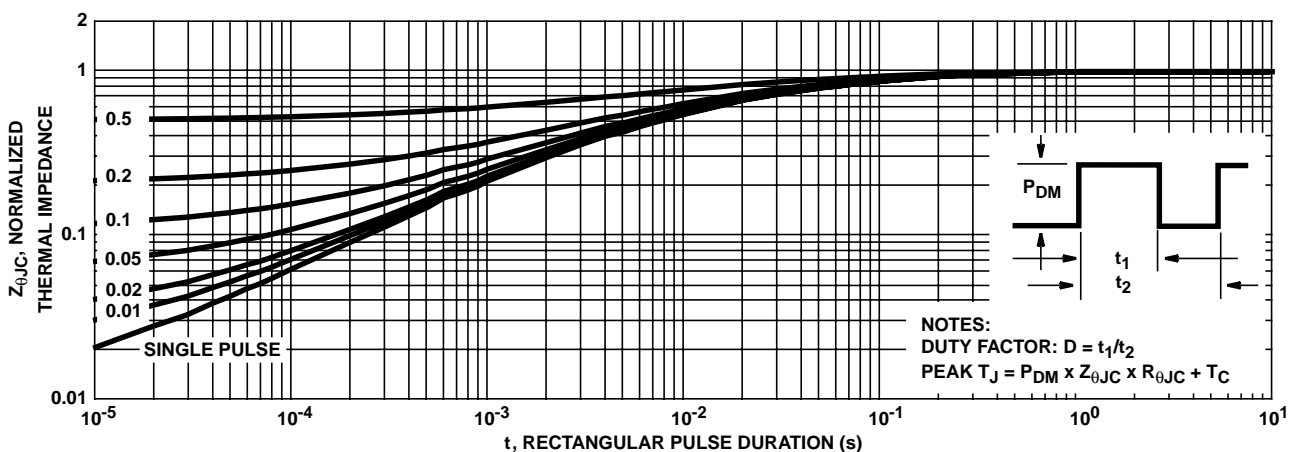

FIGURE 3. NORMALIZED MAXIMUM TRANSIENT THERMAL IMPEDANCE

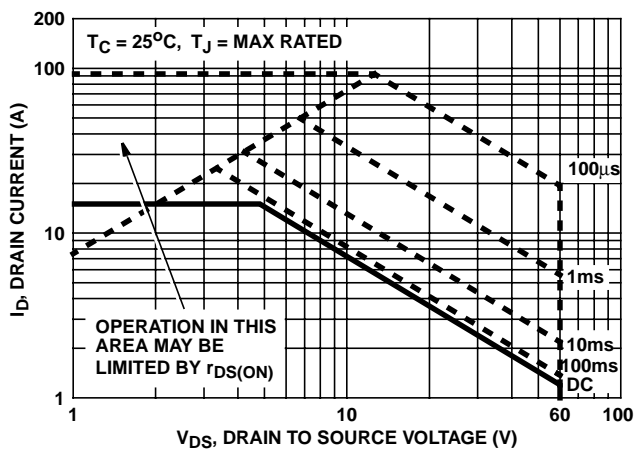

FIGURE 4. FORWARD BIAS SAFE OPERATING AREA

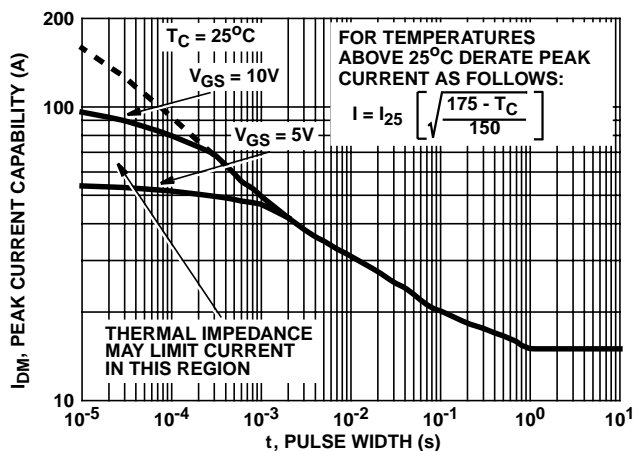
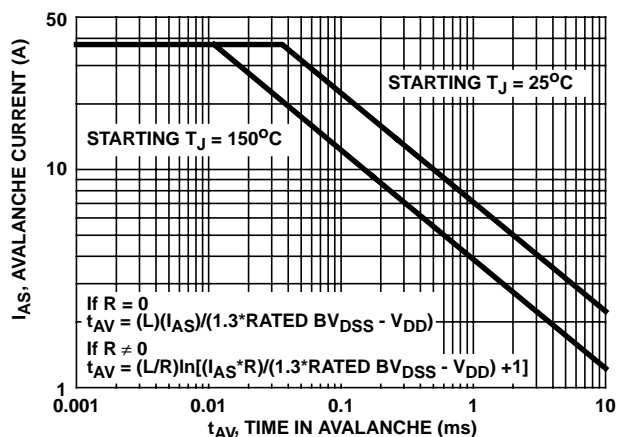

FIGURE 5. PEAK CURRENT CAPABILITY

RFD15N06LE, RFD15N06LESM

Typical Performance Curves Unless Otherwise Specified (Continued)



NOTE: Refer to Intersil Application Notes AN9321 and AN9322.

FIGURE 6. UNCLAMPED INDUCTIVE SWITCHING

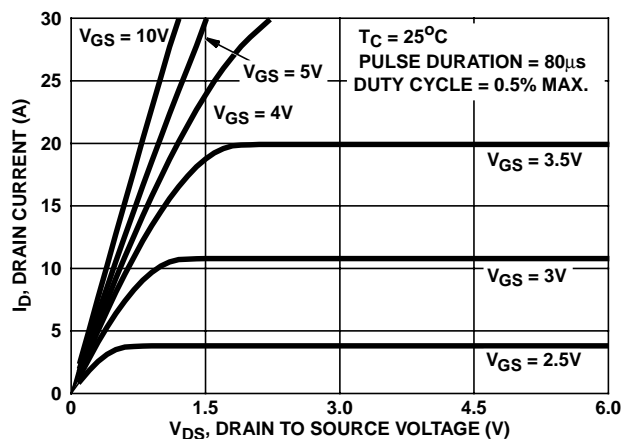

FIGURE 7. SATURATION CHARACTERISTICS

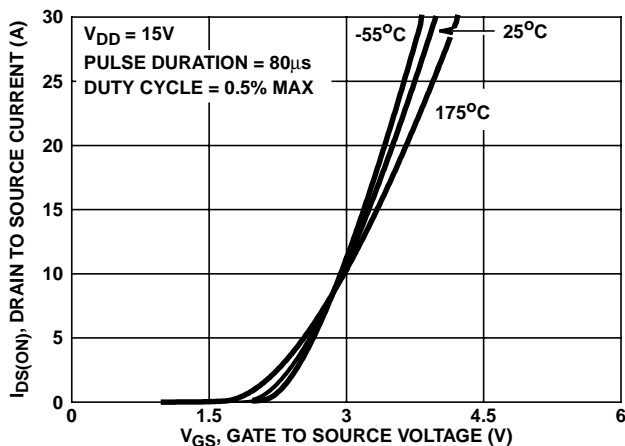

FIGURE 8. TRANSFER CHARACTERISTICS

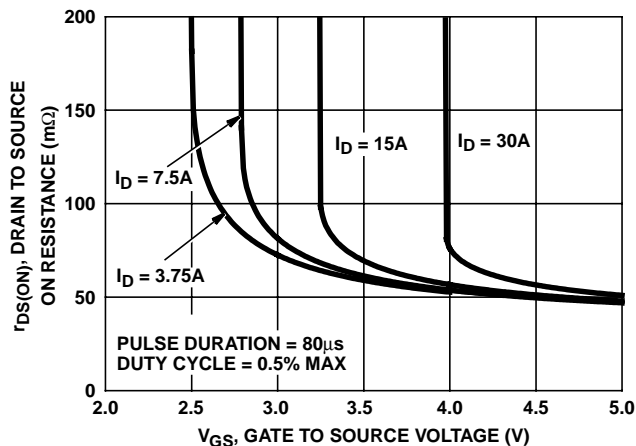

FIGURE 9. DRAIN TO SOURCE ON RESISTANCE vs GATE VOLTAGE AND DRAIN CURRENT

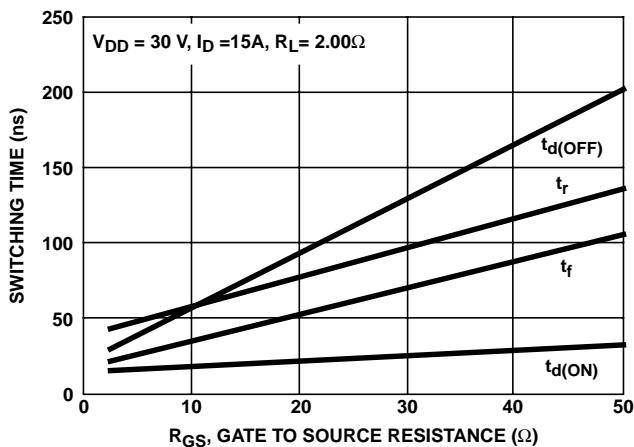

FIGURE 10. SWITCHING TIME vs GATE RESISTANCE

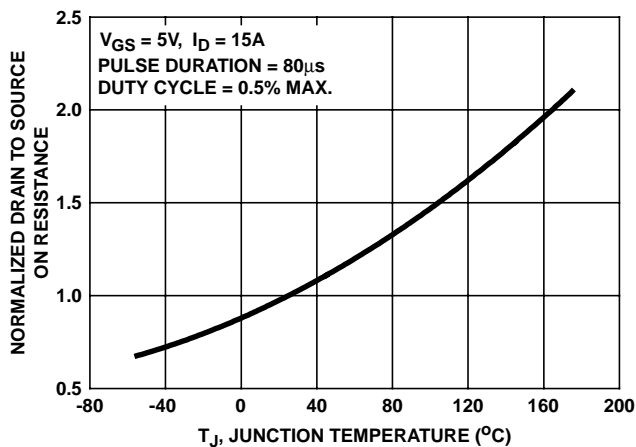

FIGURE 11. NORMALIZED DRAIN TO SOURCE ON RESISTANCE vs JUNCTION TEMPERATURE

RFD15N06LE, RFD15N06LESM

Typical Performance Curves Unless Otherwise Specified (Continued)

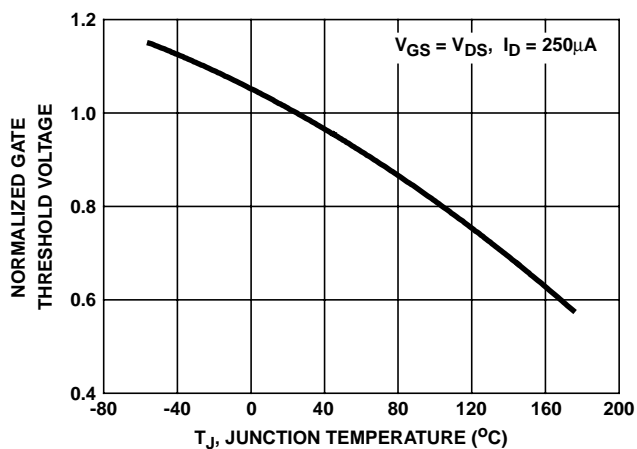

FIGURE 12. NORMALIZED GATE THRESHOLD VOLTAGE vs JUNCTION TEMPERATURE

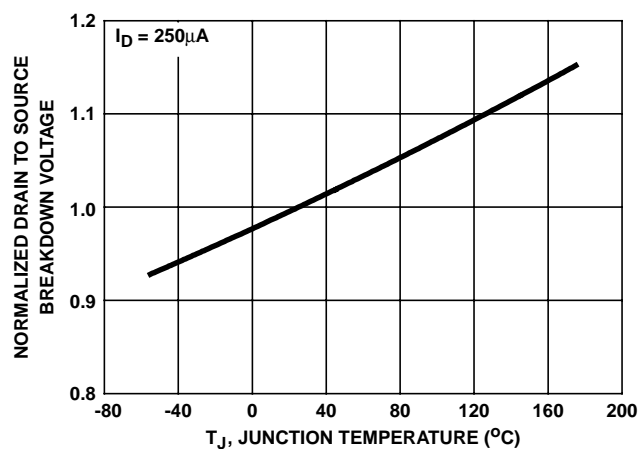

FIGURE 13. NORMALIZED DRAIN TO SOURCE BREAKDOWN VOLTAGE vs JUNCTION TEMPERATURE

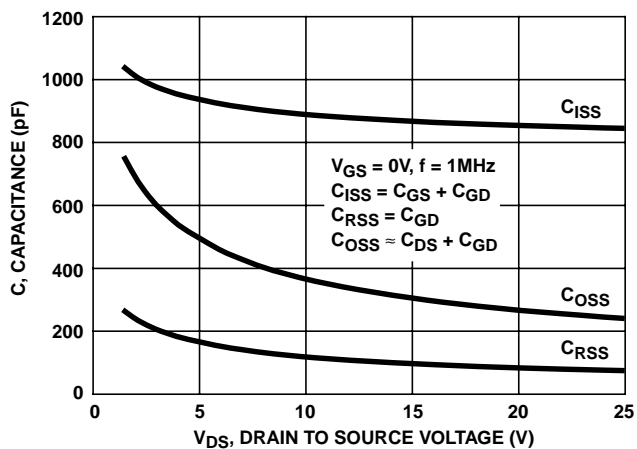
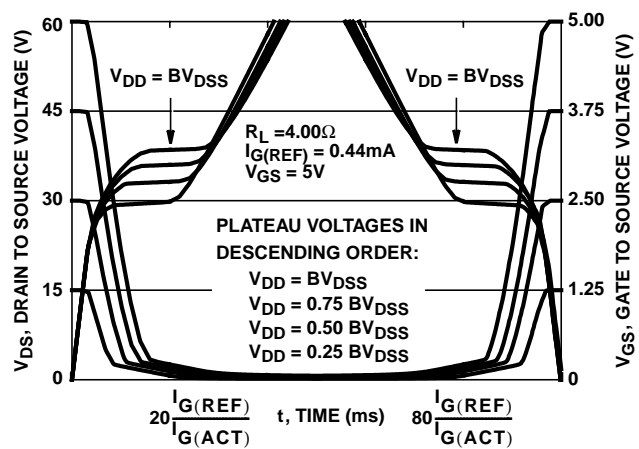

FIGURE 14. CAPACITANCE vs DRAIN TO SOURCE VOLTAGE



NOTE: Refer to Intersil Application Notes AN7254 and AN7260.

FIGURE 15. NORMALIZED SWITCHING WAVEFORMS FOR CONSTANT GATE CURRENT

Test Circuits and Waveforms

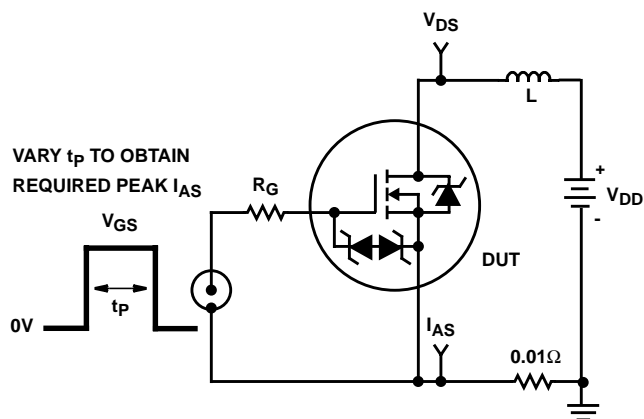

FIGURE 16. UNCLAMPED ENERGY TEST CIRCUIT

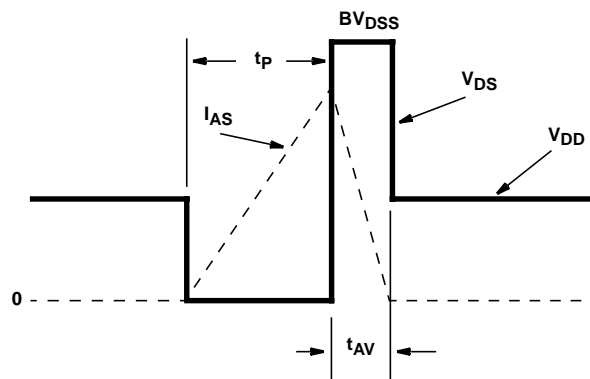

FIGURE 17. UNCLAMPED ENERGY WAVEFORMS

Test Circuits and Waveforms (Continued)

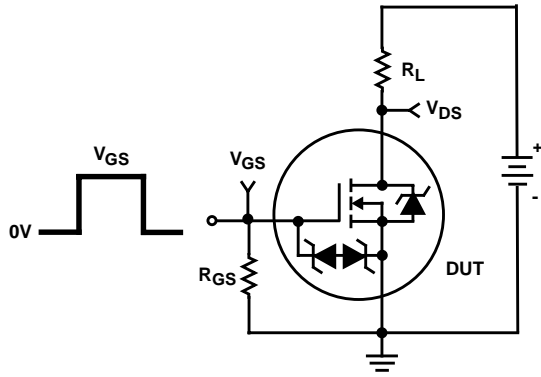

FIGURE 18. SWITCHING TIME TEST CIRCUIT

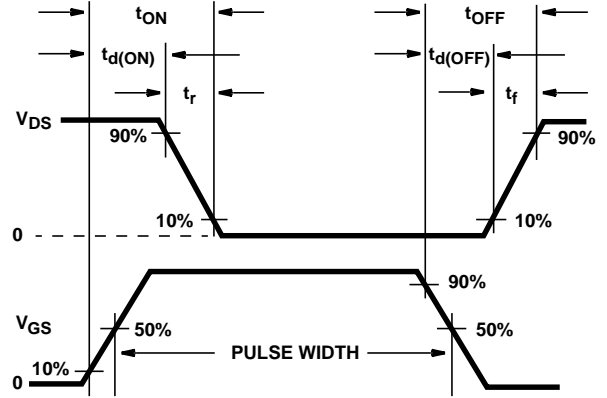

FIGURE 19. RESISTIVE SWITCHING WAVEFORMS

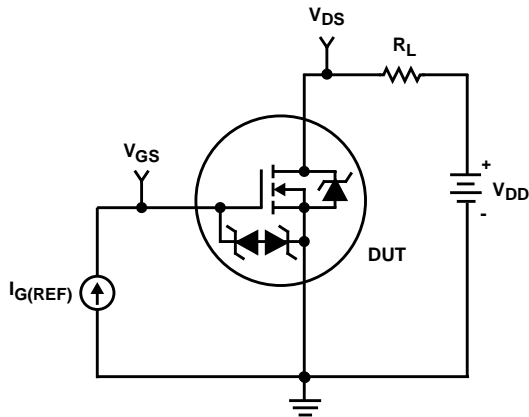

FIGURE 20. GATE CHARGE TEST CIRCUIT

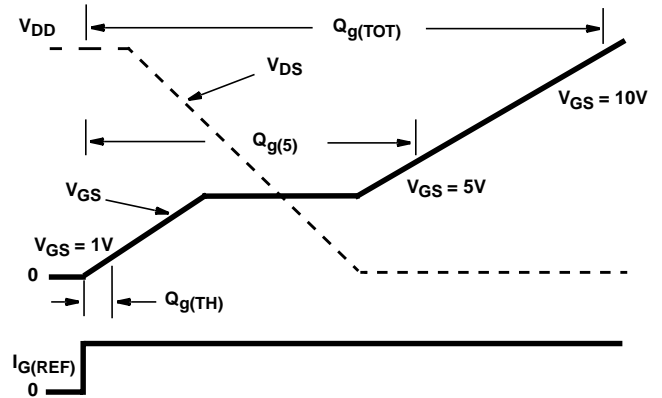

FIGURE 21. GATE CHARGE WAVEFORMS

RFD15N06LE, RFD15N06LESM

PSPICE Electrical Model

SUBCKT RFD15N06LE 2 1 3 ; rev 5/13/95

CA 12 8 2.50e-9
 CB 15 14 2.4e-9
 CIN 6 8 7.70e-10

DBODY 7 5 DBODYMOD
 DBREAK 5 11 DBREAKMOD
 DESD1 91 9 DESD1MOD
 DESD2 91 7 DESD2MOD
 DPLCAP 10 5 DPLCAPMOD

EBREAK 11 7 17 18 65.18
 EDS 14 8 5 8 1
 EGS 13 8 6 8 1
 ESG 6 10 6 8 1
 EVTHRES 6 21 19 8 1
 EVTEMP 20 6 18 22 1

IT 8 17 1

LDRAIN 2 5 1e-9
 LGATE 1 9 2.77e-9
 LSOURCE 3 7 2.98e-9

MMED 16 6 8 8 MMEDMOD
 MSTRO 16 6 8 8 MSTROMOD
 MWEAK 16 21 8 8 MWEAKMOD

RBREAK 17 18 RBREAKMOD 1
 RDRAIN 50 16 RDRAINMOD 14.52e-3
 RGATE 9 20 2.6
 RLDRAIN 2 5 10
 RLGATE 1 9 27.7
 RLSOURCE 3 7 29.8
 RSLC1 5 51 RSLCMOD 1e-6
 RSLC2 5 50 1e3
 RSOURCE 8 7 RSOURCEMOD 20.05e-3
 RVTHRES 22 8 RVTHRESMOD 1
 RVTEMP 18 19 RVTEMPMOD 1

S1A 6 12 13 8 S1AMOD
 S1B 13 12 13 8 S1BMOD
 S2A 6 15 14 13 S2AMOD
 S2B 13 15 14 13 S2BMOD

VBAT 22 19 DC 1

ESLC 51 50 VALUE = {(V(5,51)/ABS(V(5,51)))*(PWR(V(5,51))/(1e-6*72),5))}

.MODEL DBODYMOD D (IS = 6.5e-13 RS = 1.20e-2 TRS1 = 1.75e-3 TRS2 = 5.08e-6 CJO = 7.45e-10 TT = 4.61e-8 M = 0.46)
 .MODEL DBREAKMOD D (RS = 1.28e-1 TRS1 = -2.15e-3 TRS2 = 1.05e-5)
 .MODEL DESD1MOD D (BV = 12.7 TBV1 = 0 TBV2 = 0 RS = 35 TRS1 = 1.2e-6 TRS2 = 0)
 .MODEL DESD2MOD D (BV = 12.7 TBV1 = 0 TBV2 = 0 RS = 0 TRS1 = 0 TRS2 = 0)
 .MODEL DPLCAPMOD D (CJO = 4.32e-10 IS = 1e-30 N = 10 M = 0.54)
 .MODEL MMEDMOD NMOS (VTO = 1.60 KP = 1.75 IS = 1e-30 N = 10 TOX = 1 L = 1u W = 1u RG = 2.60)
 .MODEL MSTROMOD NMOS (VTO = 1.93 KP = 26.0 IS = 1e-30 N = 10 TOX = 1 L = 1u W = 1u)
 .MODEL MWEAKMOD NMOS (VTO = 1.39 KP = 0.09 IS = 1e-30 N = 10 TOX = 1 L = 1u W = 1u RG = 26.0 RS = 0.1)
 .MODEL RBREAKMOD RES (TC1 = 9.76e-4 TC2 = 5.11e-7)
 .MODEL RDRAINMOD RES (TC1 = 1.30e-2 TC2 = 4.49e-5)
 .MODEL RSLCMOD RES (TC1 = 3.00e-3 TC2 = 6.00e-6)
 .MODEL RSOURCEMOD RES (TC1 = 0 TC2 = 0)
 .MODEL RVTHRESMOD RES (TC1 = -1.43e-3 TC2 = -6.72e-6)
 .MODEL RVTEMPMOD RES (TC1 = -9.91e-4 TC2 = 1.02e-6)
 .MODEL S1AMOD VSWITCH (RON = 1e-5 ROFF = 0.1 VON = -4.85 VOFF = -1.85)
 .MODEL S1BMOD VSWITCH (RON = 1e-5 ROFF = 0.1 VON = -1.85 VOFF = -4.85)
 .MODEL S2AMOD VSWITCH (RON = 1e-5 ROFF = 0.1 VON = -1.35 VOFF = 1.65)
 .MODEL S2BMOD VSWITCH (RON = 1e-5 ROFF = 0.1 VON = 1.65 VOFF = -1.35)

.ENDS

NOTE: For further discussion of the PSPICE model, consult **A New PSPICE Sub-Circuit for the Power MOSFET Featuring Global Temperature Options**; IEEE Power Electronics Specialist Conference Records, 1991.

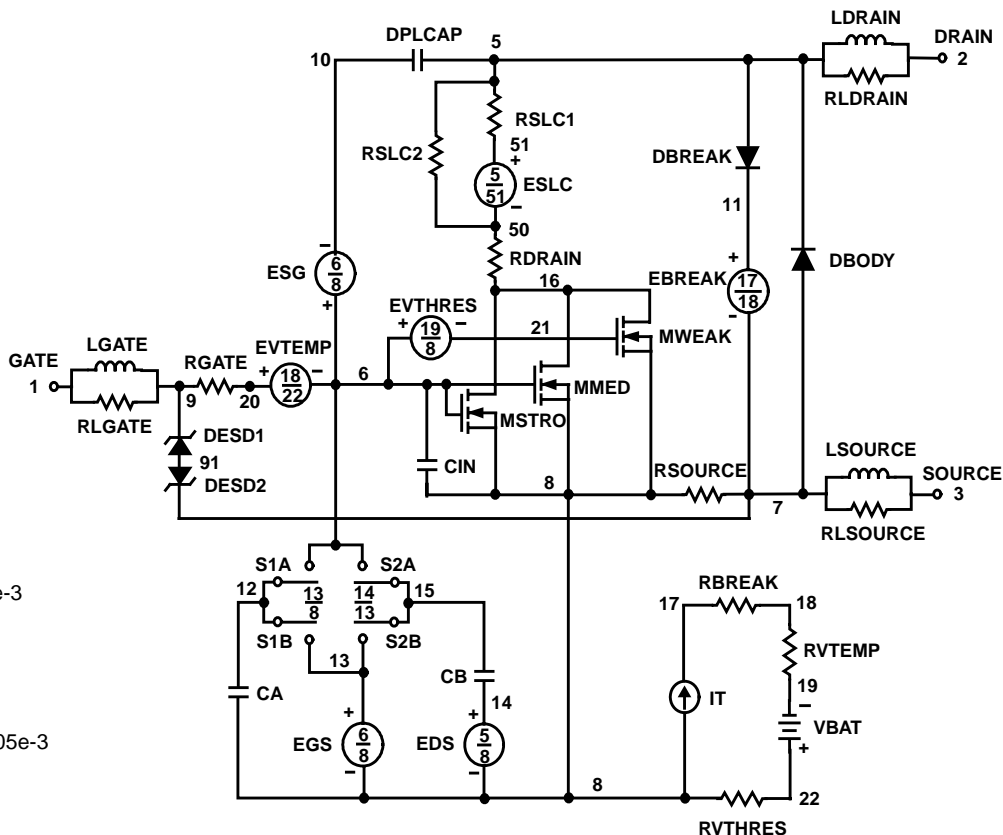

RFD15N06LE, RFD15N06LESM

All Intersil semiconductor products are manufactured, assembled and tested under **ISO9000** quality systems certification.

Intersil semiconductor products are sold by description only. Intersil Corporation reserves the right to make changes in circuit design and/or specifications at any time without notice. Accordingly, the reader is cautioned to verify that data sheets are current before placing orders. Information furnished by Intersil is believed to be accurate and reliable. However, no responsibility is assumed by Intersil or its subsidiaries for its use; nor for any infringements of patents or other rights of third parties which may result from its use. No license is granted by implication or otherwise under any patent or patent rights of Intersil or its subsidiaries.

For information regarding Intersil Corporation and its products, see web site <http://www.intersil.com>

Sales Office Headquarters

NORTH AMERICA

Intersil Corporation
P. O. Box 883, Mail Stop 53-204
Melbourne, FL 32902
TEL: (407) 724-7000
FAX: (407) 724-7240

EUROPE

Intersil SA
Mercure Center
100, Rue de la Fusee
1130 Brussels, Belgium
TEL: (32) 2.724.2111
FAX: (32) 2.724.22.05

ASIA

Intersil (Taiwan) Ltd.
7F-6, No. 101 Fu Hsing North Road
Taipei, Taiwan
Republic of China
TEL: (886) 2 2716 9310
FAX: (886) 2 2715 3029