



Micro Commercial Components
 21201 Itasca Street Chatsworth
 CA 91311
 Phone: (818) 701-4933
 Fax: (818) 701-4939

RGP10A THRU RGP10M

1.0 Amp Glass Passivated Junction Fast Recovery Rectifiers 50 to 1000 Volts

Features

- High temperature metallurgically bonded construction
- Glass passivated cavity-free junction
- 1.0 ampere operation at $T_A = 55^\circ\text{C}$ with no thermal runaway.
- Typical I_R less than 0.1uA
- Fast switching for high efficiency

Maximum Ratings

- Operating Temperature: -55°C to $+150^\circ\text{C}$
- Storage Temperature: -55°C to $+150^\circ\text{C}$
- Typical Thermal Resistance: 55°C/W Junction to Ambient

MCC Part Number	Maximum Recurrent Peak Reverse Voltage	Maximum RMS Voltage	Maximum DC Blocking Voltage
RGP10A	50V	35V	50V
RGP10B	100V	70V	100V
RGP10D	200V	140V	200V
RGP10G	400V	280V	400V
RGP10J	600V	420V	600V
RGP10K	800V	560V	800V
RGP10M	1000V	700V	1000V

Electrical Characteristics @ 25°C Unless Otherwise Specified

Maximum Average Forward Current	$I_{F(AV)}$	1.0 A	$T_A = 55^\circ\text{C}$
Peak Forward Surge Current	I_{FSM}	30A	8.3ms, half sine
Maximum Instantaneous Forward Voltage	V_F	1.3V	$I_{FM} = 1.0A;$ $T_A = 25^\circ\text{C}$
Maximum DC Reverse Current At Rated DC Blocking Voltage	I_R	5.0uA 200uA	$T_A = 25^\circ\text{C}$ $T_A = 150^\circ\text{C}$
Typical Junction Capacitance	C_J	15pF	Measured at 1.0MHz, $V_R=4.0V$
Maximum Reverse Recovery Time	T_{rr}	150nS 250nS 500nS	$T_J=25^\circ\text{C}$ $I_F=0.5A$ $I_R=1.0A$ $I_{RR}=0.25A$

DO-41

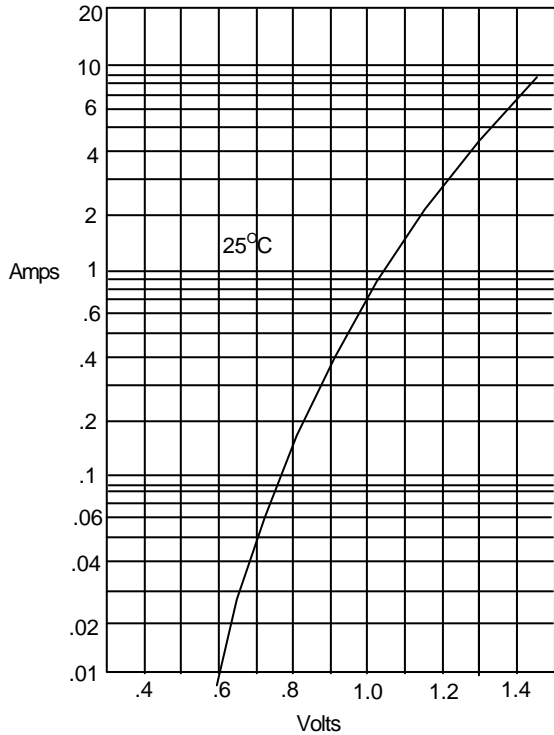
The diagram shows a DO-41 package with dimensions A, B, C, and D. A cathode mark is also indicated.

DIMENSIONS					
DIM	INCHES		MM		NOTE
	MIN	MAX	MIN	MAX	
A	.166	.205	4.10	5.20	
B	.080	.107	2.00	2.70	
C	.028	.034	.70	.90	
D	1.000	---	25.40	---	

RGP10A thru RGP10M

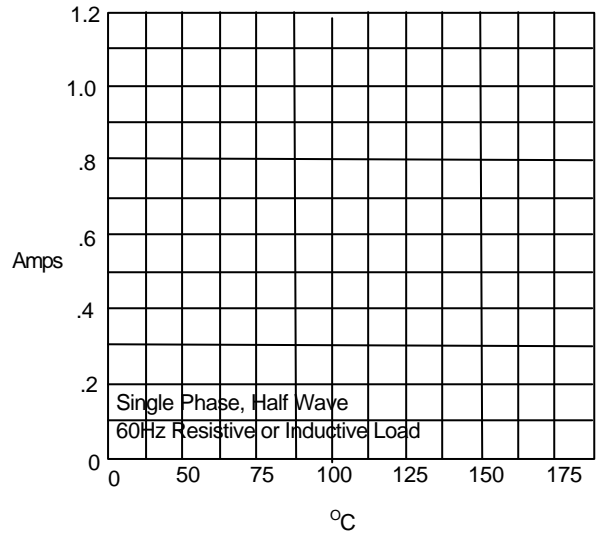


Figure 1
Typical Forward Characteristics



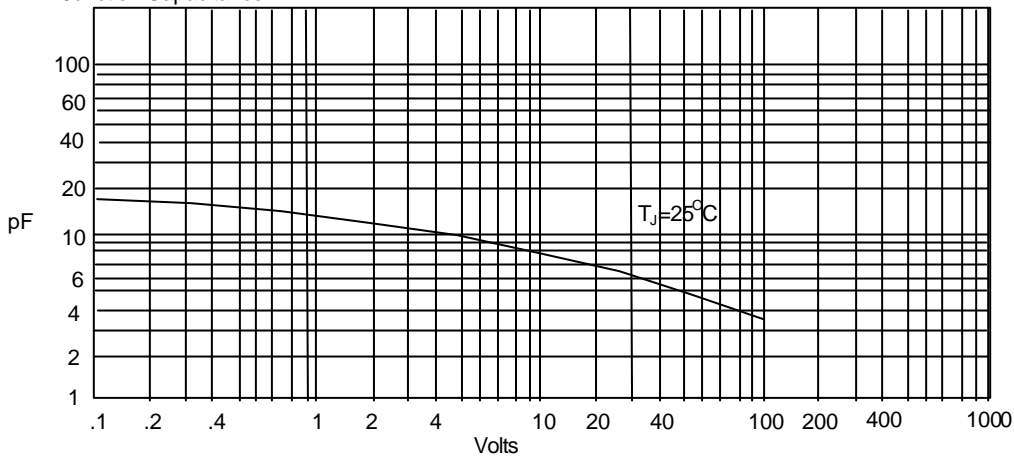
Instantaneous Forward Current - Amperes versus
Instantaneous Forward Voltage - Volts

Figure 2
Forward Derating Curve



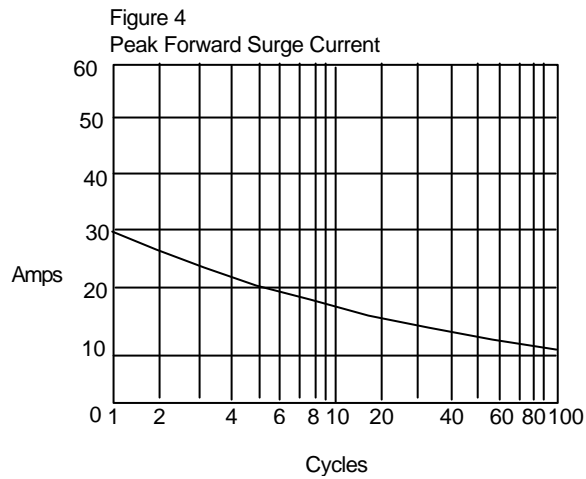
Average Forward Rectified Current - Amperes versus
Ambient Temperature - °C

Figure 3
Junction Capacitance



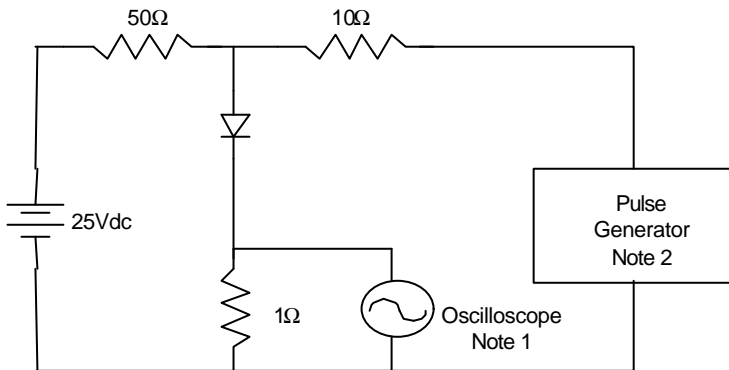
Junction Capacitance - pF versus
Reverse Voltage - Volts

RGP10A thru RGP10M



Peak Forward Surge Current - Amperes versus Number Of Cycles At 60Hz - Cycles

Figure 5
Reverse Recovery Time Characteristic And Test Circuit Diagram



- Notes:
1. Rise Time = 7ns max.
Input impedance = 1 megohm, 22pF
 2. Rise Time = 10ns max.
Source impedance = 50 ohms
 3. Resistors are non-inductive

