



DESCRIPTION

The RH108A is a precision operational amplifier particularly well-suited for high source impedance applications requiring low offset and bias currents and low power consumption.

The wafer lots are processed to Linear Technology's in-house Class S flow to yield circuits usable in stringent military applications.

For complete electrical specifications, performance curves and applications information, see the LM108A/LM108 data sheet.

ABSOLUTE MAXIMUM RATINGS

Supply Voltage	±20V
Differential Input Current (Note 1)	±10mA
Input Voltage (Note 2)	±15V
Output Short-Circuit Duration	Indefinite
Operating Temperature Range	-55°C to 125°C
Storage Temperature Range	-65°C to 150°C
Lead Temperature (Soldering, 10 sec)	300°C

LT, LTC and LT are registered trademarks of Linear Technology Corporation.

BURN-IN CIRCUIT

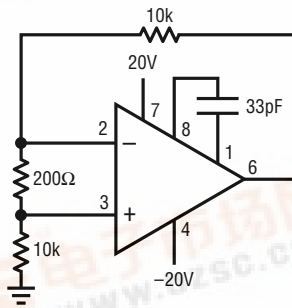

OR

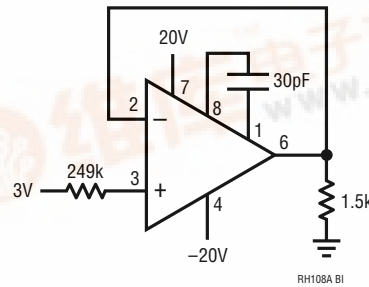

RH108A BI

PACKAGE INFORMATION

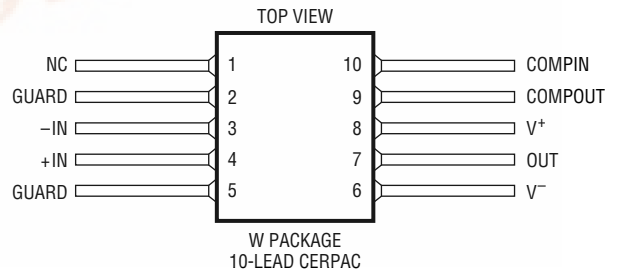
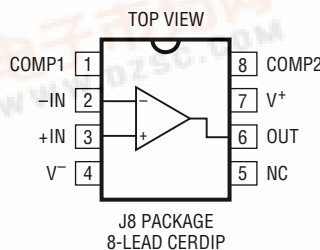
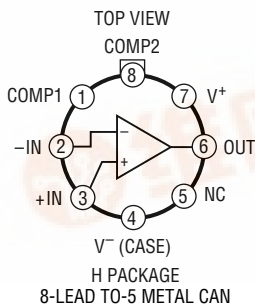

TABLE 1: ELECTRICAL CHARACTERISTICS (Preirradiation) (Note 4)

SYMBOL	PARAMETER	CONDITIONS	NOTES	T _A = 25°C			SUB-GROUP	-55°C T _A 125°C			SUB-GROUP	UNITS
				MIN	TYP	MAX		MIN	TYP	MAX		
V _{OS}	Input Offset Voltage					0.5	1			1.0	2,3	mV
$\frac{V_{OS}}{\text{Temp}}$	Average Tempco of Offset Voltage		3							5.0		μV/°C
I _{OS}	Input Offset Current					0.2	1			0.4	2,3	nA
$\frac{I_{OS}}{\text{Temp}}$	Average Tempco of Offset Current		3							2.5		pA/°C
I _B	Input Bias Current					2.0	1			3.0	2,3	nA
A _{VOL}	Large-Signal Voltage Gain	V _S = ±15V, V _{OUT} = ±10V R _L 10k				80	4			40	5,6	V/mV
CMRR	Common Mode Rejection Ratio					96	1			96	2,3	dB
PSRR	Power Supply Rejection Ratio					96	1			96	2,3	dB
	Input Voltage Range	V _S = ±15V	3			±13.5				±13.5		V
V _{OUT}	Output Voltage Swing	V _S = ±15V, R _L = 10k				±13	4			±13	5,6	V
R _{IN}	Input Resistance		3			30						M
I _S	Supply Current	(Note 6)				0.6	1			0.4	2	mA

TABLE 1A: ELECTRICAL CHARACTERISTICS (Postirradiation) (Note 5)

SYMBOL	PARAMETER	CONDITIONS	NOTES	10KRAD(Si)		20KRAD(Si)		50KRAD(Si)		80KRAD(Si)		UNITS
				MIN	MAX	MIN	MAX	MIN	MAX	MIN	MAX	
V _{OS}	Input Offset Voltage				0.5		0.5		0.5		1.0	mV
I _{OS}	Input Offset Current				0.2		0.2		0.2		0.2	nA
I _B	Input Bias Current				±2.0		±2.0		±2.0		±4.0	nA
A _{VOL}	Large-Signal Voltage Gain	V _S = ±15V, V _{OUT} = ±10V R _L 10k			98		98		90		86	dB
CMRR	Common Mode Rejection Ratio				96		96		84		70	dB
PSRR	Power Supply Rejection Ratio				96		96		84		70	dB
	Input Voltage Range		3		±13.5		±13.5		±13.5		±13.5	V
V _{OUT}	Output Voltage Swing				±13		±13		±13		±13	V
R _{IN}	Input Resistance		3		30		30		30		30	M
I _S	Supply Current				0.6		0.6		0.6		0.6	mA

Note 1: Differential input voltages greater than 1V will cause excessive current to flow through the input diodes unless limiting resistance is used.

Note 2: For supply voltages less than ±15V, the maximum input voltage is equal to the supply voltage.

Note 3: Guaranteed by design, characterization or correlation to other tested parameters.

Note 4: ±5V V_S ±20V unless otherwise noted.

Note 5: V_S = ±15V, V_{CM} = 0V, T_A = 25°C unless otherwise noted.

Note 6: 25°C T_A 125°C.

TABLE 2: ELECTRICAL TEST REQUIREMENTS

MIL-STD-883 TEST REQUIREMENTS	SUBGROUP
Final Electrical Test Requirements (Method 5004)	1*,2,3,4,5,6
Group A Test Requirements (Method 5005)	1,2,3,4,5,6
Group C and D End Point Electrical Parameters (Method 5005)	1

* PDA Applies to subgroup 1. See PDA Test Notes.

PDA Test Notes

The PDA is specified as 5% based on failures from group A, subgroup 1, tests after cooldown as the final electrical test in accordance with method 5004 of MIL-STD-883 Class B. The verified failures (including Delta parameters) of group A, subgroup 1, after burn-in divided by the total number of devices submitted for burn-in in that lot shall be used to determine the percent for the lot.

Linear Technology Corporation reserves the right to test to tighter limits than those given.

TOTAL DOSE BIAS CIRCUIT

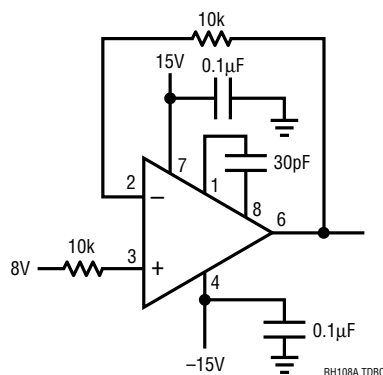

TYPICAL PERFORMANCE CHARACTERISTICS

Input Offset Voltage

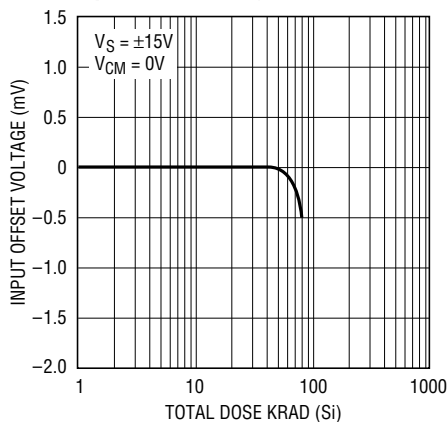

RH108A G01

Input Bias Current

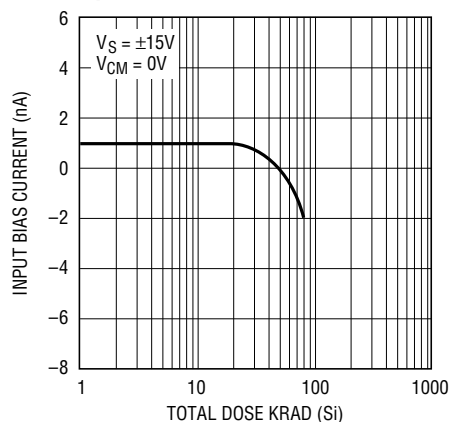

RH108A G02

Input Offset Current

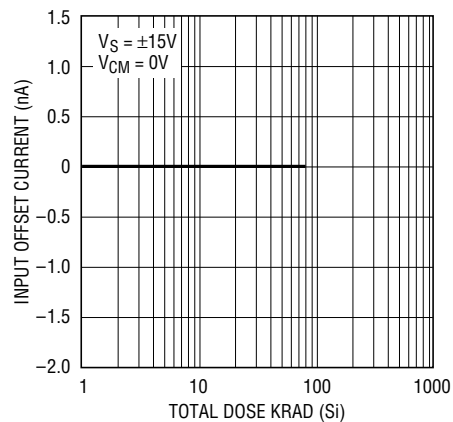

RH108A G03

Open-Loop Gain

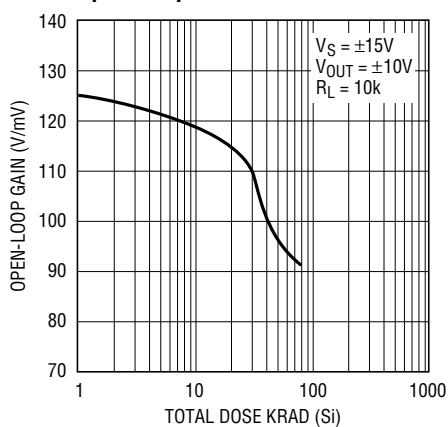

RH108A G04

Common Mode Rejection Ratio

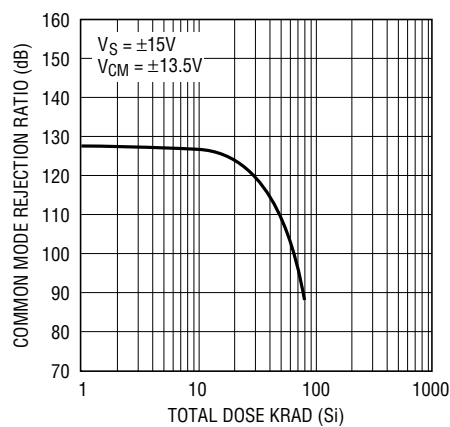

RH108A G05

Power Supply Rejection Ratio

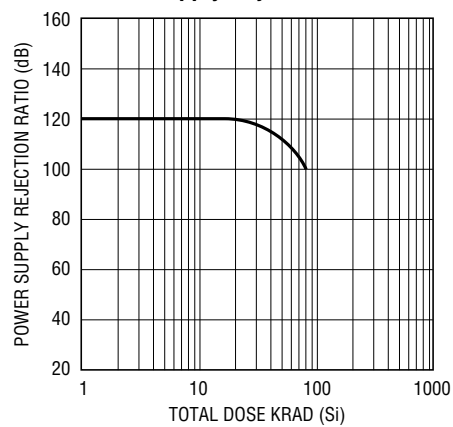

RH108A G06