

Diodes

Switching diode

RLS-73

●Applications

High speed switching

●Features

- 1) Small surface mounting type. (LLDS)
- 2) High speed. ($t_{tr}=1.2ns$ Typ.)
- 3) High reliability.

●Construction

Silicon epitaxial planar

●External dimensions (Units : mm)

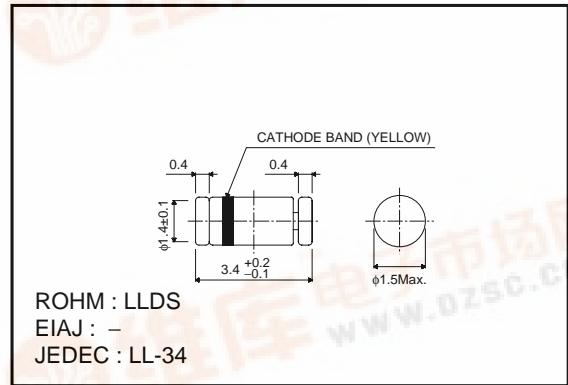

●Absolute maximum ratings (Ta=25°C)

Parameter	Symbol	Limits	Unit
Peak reverse voltage	V_{RM}	90	V
DC reverse voltage	V_R	80	V
Peak forward current	I_{FM}	400	mA
Mean rectifying current	I_o	130	mA
Surge current (1s)	I_{surge}	600	mA
Power dissipation	P	300	mW
Junction temperature	T_j	175	°C
Storage temperature	T_{stg}	-65~+175	°C

●Electrical characteristics (Ta=25°C)

Parameter	Symbol	Min.	Typ.	Max.	Unit	Conditions
Forward voltage	V_F	-	-	1.2	V	$I_F=100mA$
Reverse current	I_R	-	-	0.5	μA	$V_R=80V$
Capacitance between terminals	C_T	-	-	2	pF	$V_R=0.5V, f=1MHz$
Reverse recovery time	t_{rr}	-	-	4	ns	$V_R=6V, I_F=10mA, R_L=50\Omega$

Diodes

●Electrical characteristic curves (Ta=25°C)

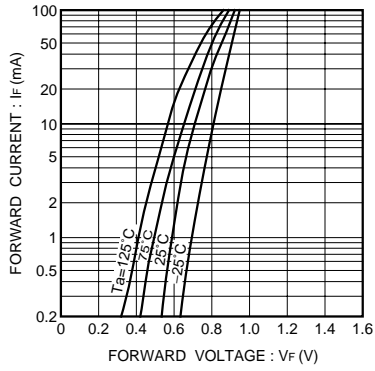

Fig. 1 Forward characteristics

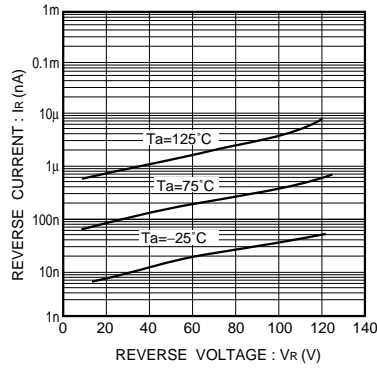

Fig. 2 Reverse characteristics

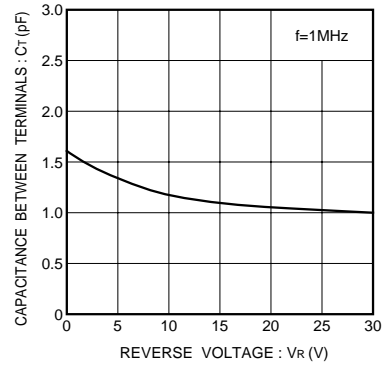

Fig. 3 Capacitance between terminals characteristics

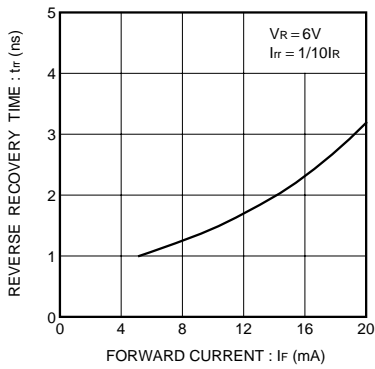

Fig. 4 Reverse recovery time characteristics

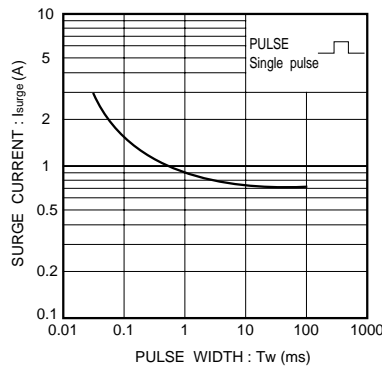

Fig. 5 Surge current characteristics

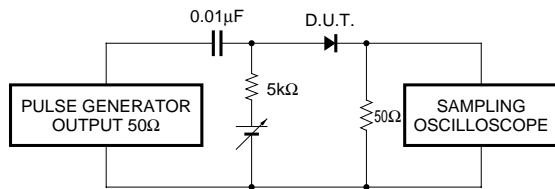

Fig. 6 Reverse recovery time (tr) measurement circuit