

RM805

Power Amplifier Module for Broadband

The RM805 Power Amplifier (PA) is a fully matched 28-pin surface mount module designed for Private Mobile Radio (PMR), Wireless Local Loop (WLL), and Time Division Multiple Access/Advanced Mobile Phone Service (TDMA/AMPS) mobile units operating in the 806-849 MHz cellular bandwidth. Microwave Monolithic Integrated Circuits (MMICs), comprised of Gallium Arsenide (GaAs) and CMOS, contain all active circuitry in the module, which includes on-board bias circuitry as well as input and interstage matching circuits. The output match is realized off-chip within the module package to optimize efficiency and high power performance ($P_{3db_sat} \cong 35.8 \text{ dBm}$) into a 50Ω load.

This device, manufactured with Skyworks' GaAs Heterojunction Bipolar Transistor (HBT) and silicon CMOS processes, provides for all positive voltage DC supply operation while maintaining high efficiency and good linearity. Primary bias to the RM805 can be supplied directly from a single cell lithium-ion or other suitable battery with a nominal output 3.5 Volts.

No external supply side switch is needed as typical "off" leakage is a few microamperes with full primary voltage supplied from the battery.

Distinguishing Features

- Low voltage positive bias supply
- Good linearity
- High efficiency
- Dual mode operation
- Large dynamic range
- 28-pin LCC package (10 x 13.97 x 1.7 mm)
- Power down control

Applications

- PMR (806–825 MHz)
- TETRA (806–825 MHz)
- TDMA (824–849 MHz)
- AMPS (824–849 MHz)
- Wireless Local Loop

Functional Block Diagram

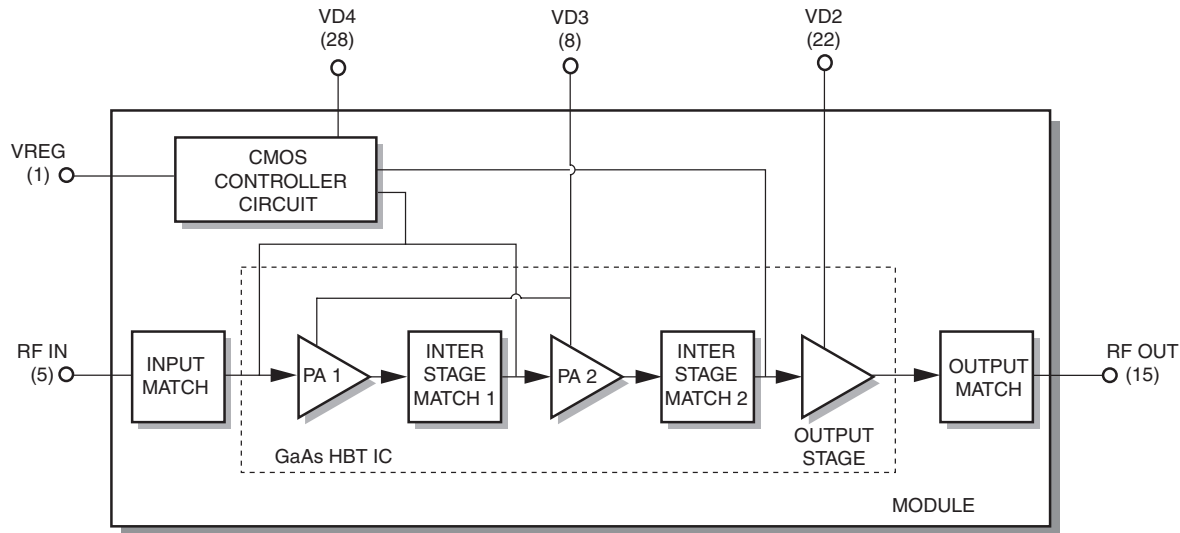

Electrical Specifications

The following tables list the electrical characteristics of the RM805 Power Amplifier. [Table 1](#) lists the absolute maximum rating for continuous operation. [Table 2](#) lists the recommended operating conditions for achieving the electrical performance listed in [Table 3](#), which depicts the electrical performance of the RM805 Power Amplifier over the recommended operating conditions.

Table 1. Absolute Maximum Ratings⁽¹⁾

Parameter	Symbol	Minimum	Nominal	Maximum	Unit
RF Input Power ⁽²⁾	Pin	—	-8.0	11.0	dBm
Supply Voltage	Vcc	—	3.5	6.9 ⁽³⁾	Volts
Regulation Voltage	Vreg	0.0	2.75	Vcc ⁽⁴⁾	Volts
Case Operating Temperature	Tc	-30	+25	+110	°C
Storage Temperature	Tstg	-55	—	+125	°C
NOTE(S): (1) No damage assuming only one parameter is set at limit at a time with all other parameters set at or below nominal value. (2) Pulsed operation at 25% duty cycle. (3) When amplifier is biased off (Vreg = 0 V) (4) Voltage on Vreg pin may not exceed the applied Vcc voltage.					

Table 2. Recommended Operating Conditions

Parameter	Symbol	Minimum	Nominal	Maximum	Unit
Supply Voltage	Vcc	3.0	3.5	4.4	Volts
Regulation Voltage	Vreg	2.65	2.75	2.85	Volts
Operating Frequency	Fo	806	—	849	MHz
Continuous RMS Output Power	PoRMS		29.0	31.0	dBm
Operating Temperature	To	-30	+25	+85	°C

Power Amplifier Module for Broadband

Table 3. Electrical Specifications for TDMA/AMPS Nominal Operating Conditions⁽¹⁾

Characteristics	Condition	Symbol	Minimum	Typical	Maximum	Unit
Quiescent current	Vreg = 2.75	I _q	332	370	450	mA
Gain	P _o = 29 dBm	G _p	35.5	38.0	40.0	dB
Saturated Output Power	Duty Cycle ≤ 25% Gain Compression ≤ 3 dB	P3dB sat	35.3	35.8	—	dBm
Power Added Efficiency	P _o = 29 dBm P _o = P3dB sat	PAE _a	21.0	23.0	—	%
		PAE _d	48.0	52.0	—	%
Harmonic Levels	Second	P _o ≤ P3db sat	—	-10.0	—	dBm
	Third	P _o ≤ P3db sat	—	-30.0	—	dBm
	Fourth	P _o ≤ P3db sat	—	-30.0	—	dBm
Noise Power in RX Band F _c + 30 MHz, BW = 18 kHz	P _o ≤ 29 dBm	RxBN	—	—	-85.0	dBm/Hz
Noise Figure	—	NF	—	8.0	—	dB
Input Voltage Standing Wave Ratio	—	VSWR	—	1.3:1	2.0:1	—
Stability (Spurious output)	—	S	10.0:1	—	-36.0	dBm
Ruggedness – No damage	P _o ≤ 29 dBm	Ru	15.0:1	—	—	VSWR
NOTE(S): (1) V _{cc} = +3.5 V, Vreg = +2.75 V, Freq = 815 MHz, T _c = 25 °C, Vreg pulsed at 25% duty cycle, unless otherwise specified.						

Evaluation Board Description

The evaluation board is a platform for testing and interfacing design circuitry. To accommodate the interface testing of the RM805, the evaluation board schematic and assembly diagram are included for preliminary analysis and design. [Figure 1](#) shows the basic schematic of the board for the 806 MHz to 849 MHz range and [Figure 2](#) illustrates the board layout.

Figure 1. Evaluation Board Schematic

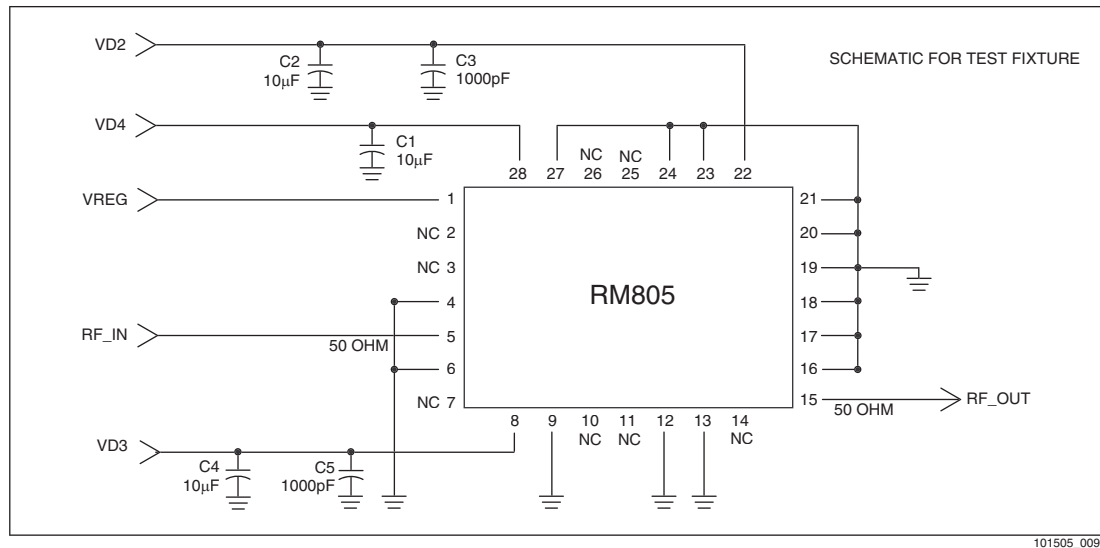

101505-009

Figure 2. Evaluation Board Assembly Diagram

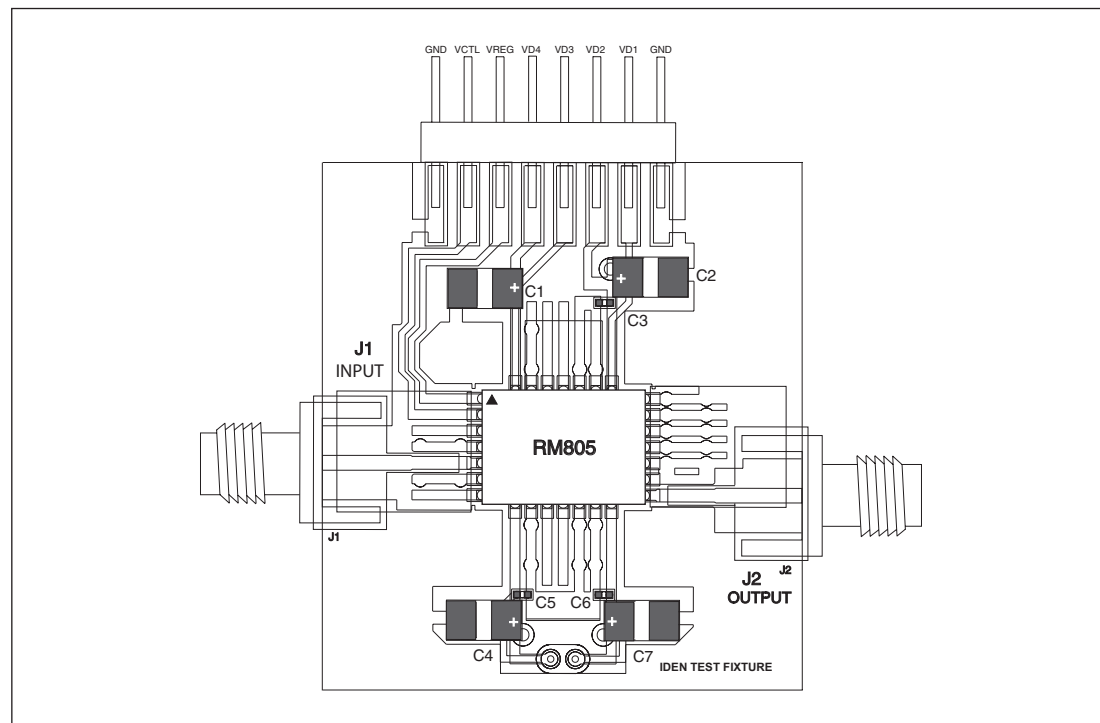

101505-007

Package Dimensions and Pin Descriptions

The RM805 is a multi-layer laminate base, overmold encapsulated modular package designed for surface mount solder attachment to a printed circuit board.

Figure 3. RM805 Package Dimensions

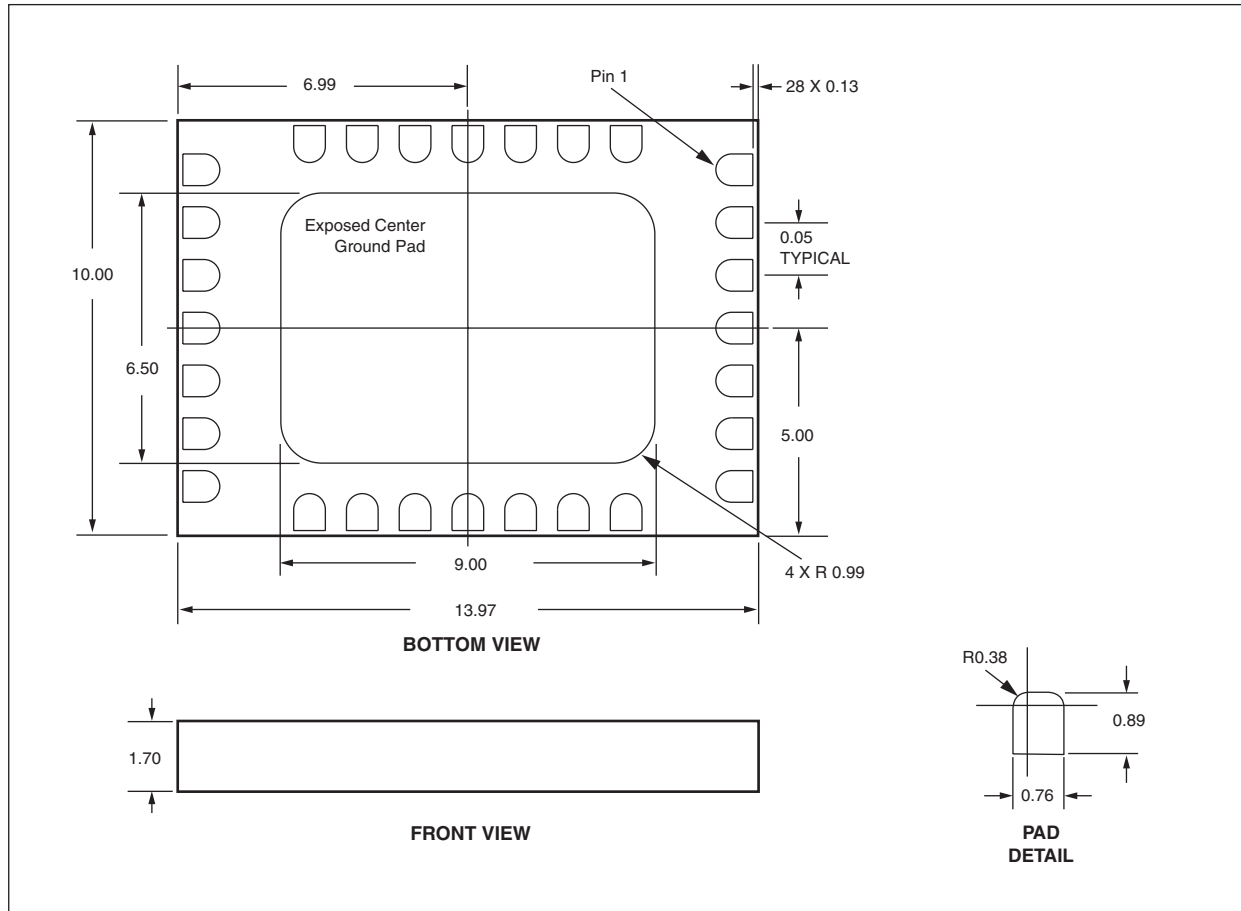

101505_006

Table 4. Pin Names and Descriptions

Pad	Pad Name	Description
1	VREG1	Regulated bias enable control voltage, 0.0=Off, 2.75V=On
2	VCNTL	Reserved for gain adjust control, currently a floating pad
3	GND1	Low Inductance Ground Connection
4	GND2	Low Inductance Ground Connection
5	RFIN	806-849 MHz RF input signal (typically -8 dBm) 50 Ohm
6	GND3	Low Inductance Ground Connection
7	VREG2	Reserved for additional VREG signal, currently a floating pad
8	VD3	Supply voltage for driver collector bias (typically 3.5V)
9	GND4	Low Inductance Ground Connection
10	RSVD	Used to identify device, Skyworks pad must float
11	GND5	Low Inductance Ground Connection
12	GND6	Low Inductance Ground Connection
13	GND7	Low Inductance Ground Connection
14	VD1	Unused supply voltage, currently a floating pad
15	RFOUT	806-849 MHz RF output signal (typically +29 dBm) 50 Ohm
16	GND8	Low Inductance Ground Connection
17	GND9	Low Inductance Ground Connection
18	GND10	Low Inductance Ground Connection
19	GND11	Low Inductance Ground Connection
20	GND12	Low Inductance Ground Connection
21	GND13	Low Inductance Ground Connection
22	VD2	Supply voltage for output (final) stage collector bias (typically 3.5V)
23	GND14	Low Inductance Ground Connection
24	GND15	Low Inductance Ground Connection
25	GND16	Low Inductance Ground Connection
26	GND17	Low Inductance Ground Connection
27	GND18	Low Inductance Ground Connection
28	VD4	Supply voltage for base bias circuitry to all stages (typically 3.5V)
NOTE(S): Center attachment pad must have a low inductance and low thermal resistance connection to the customer's printed circuit board ground plane.		

Package and Handling Information

Because of its sensitivity to moisture absorption, this device package is baked and vacuum packed prior to shipment. Instructions on the shipping container label must be followed regarding exposure to moisture after the container seal is broken, otherwise, problems related to moisture absorption may occur when the part is subjected to high temperature during solder assembly.

The RM805 is capable of withstanding an MSL 3/225 °C solder reflow. Care must be taken when attaching this product, whether it is done manually or in a production solder reflow environment. If the part is attached in a reflow oven, the temperature ramp rate should not exceed 5 °C per second; maximum temperature should not exceed 225 °C. If the part is manually attached, precaution should be taken to insure that the part is not subjected to temperatures exceeding 225 °C for more than 10 seconds. For details on both attachment techniques, precautions, and handling procedures recommended by Skyworks, please refer to *Application Note: PCB Design and SMT Assembly/Rework, Document Number 101752*. Additional information on standard SMT reflow profiles can also be found in the *JEDEC Standard J-STD-020A*.

Production quantities of this product are shipped in the standard tape-and-reel format. For packaging details, refer to *Application Note: Tape and Reel, Document Number 101568*.

Figure 4. Typical Case Markings

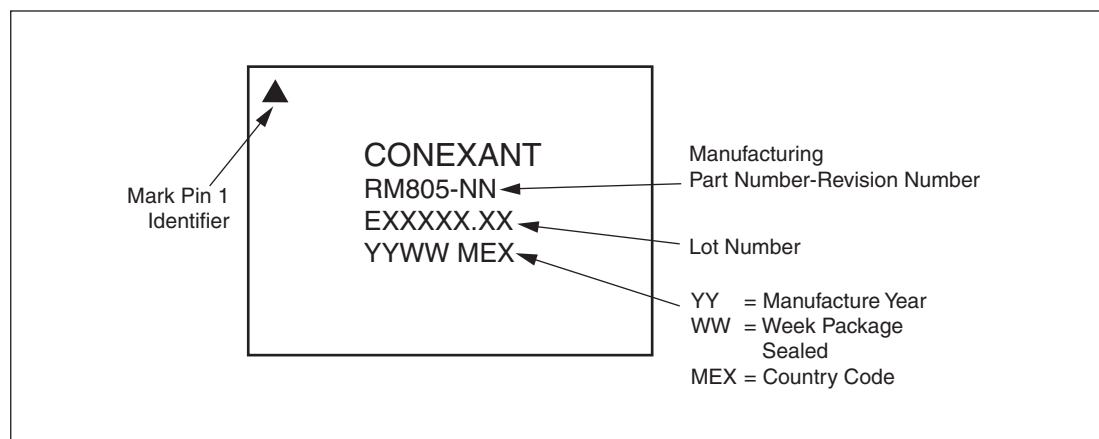

Electrostatic Discharge Sensitivity

The RM805 is a Class I device. Figure 5 lists the Electrostatic Discharge (ESD) immunity level for each pin of the RM805 product. The numbers in Figure 5 specify the ESD threshold level for each pin where the I-V curve between the pin and ground starts to show degradation. The ESD testing was performed in compliance with MIL-STD-883E Method 3015.7 using the Human Body Model. Since 2000 volts represents the maximum measurement limit of the test equipment used, pins marked > 2000 V pass 2000V ESD stress.

Figure 5. ESD Sensitivity Areas

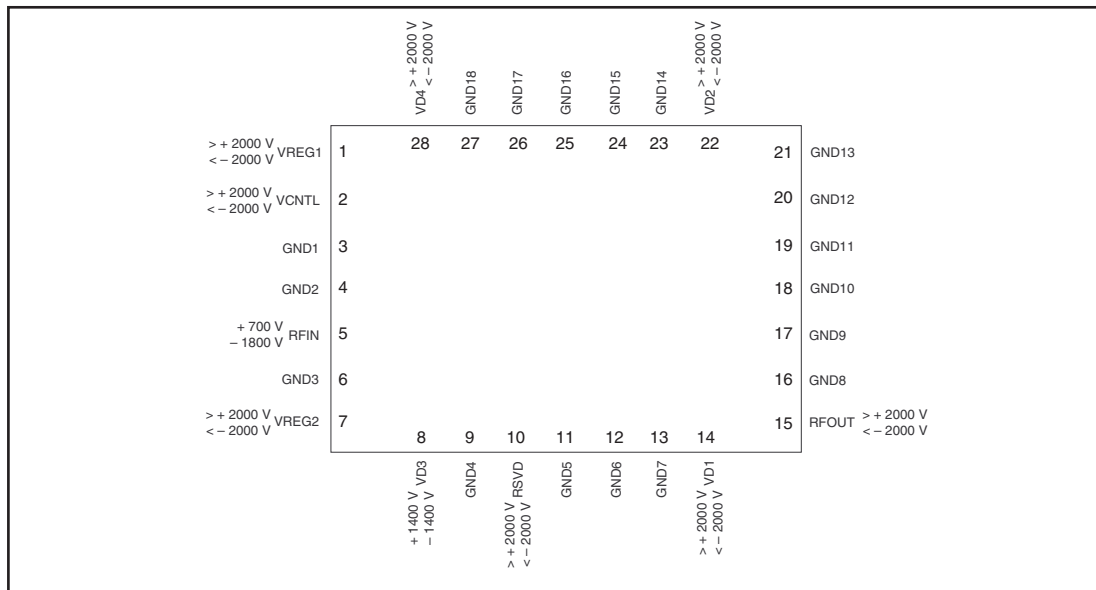

101505_005

Various failure criteria can be utilized when performing ESD testing. Many vendors employ relaxed ESD failure standards which fail devices only after “the pin fails the electrical specification limits” or “the pin becomes completely non-functional”. Skyworks employs most stringent criteria, fails devices as soon as the pin begins to show any degradation on a curve tracer.

To avoid ESD damage, both latent and visible, it is very important that the product assembly and test areas follow the Class-1 ESD handling precautions listed in Table 5.

Table 5. Precautions for GaAs ICs with ESD Thresholds Greater Than 200V But Less Than 2000V

<p>Personnel Grounding</p> <p>Wrist Straps Conductive Smocks, Gloves and Finger Cots Antistatic ID Badges</p>	<p>Facility</p> <p>Relative Humidity Control and Air Ionizers Dissipative Floors (less than 10⁹ Ω to GND)</p>
<p>Protective Workstation</p> <p>Dissipative Table Tops Protective Test Equipment (Properly Grounded) Grounded Tip Soldering Irons Conductive Solder Suckers Static Sensors</p>	<p>Protective Packaging & Transportation</p> <p>Bags and Pouches (Faraday Shield) Protective Tote Boxes (Conductive Static Shielding) Protective Trays Grounded Carts Protective Work Order Holders</p>

Ordering Information

Model Number	Manufacturing Part Number	Product Revision	Package	Operating Temperature
RM805	RM805-17	17	10.0 x 13.97 x 1.7mm	-30 °C to +85 °C

Revision History

Revision	Level	Date	Description
A		May 2001	Initial Release
B		August 2001	Revise: Product Description/Applications
C		June 17, 2002	Revise: ESD data; Update: References Information
D		December 6, 2002	Updated Product Revision to 17

References

Application Note: Tape and Reel, Document Number 101568

Application Note: PCB Design and SMT Assembly/Rework, Document Number 101752

© 2000–2002, Skyworks Solutions, Inc. All Rights Reserved.

Information in this document is provided in connection with Skyworks Solutions, Inc. ("Skyworks") products. These materials are provided by Skyworks as a service to its customers and may be used for informational purposes only. Skyworks assumes no responsibility for errors or omissions in these materials. Skyworks may make changes to its products, specifications and product descriptions at any time, without notice. Skyworks makes no commitment to update the information and shall have no responsibility whatsoever for conflicts, incompatibilities, or other difficulties arising from future changes to its products and product descriptions.

No license, express or implied, by estoppel or otherwise, to any intellectual property rights is granted by this document. Except as may be provided in Skyworks' Terms and Conditions of Sale for such products, Skyworks assumes no liability whatsoever.

THESE MATERIALS ARE PROVIDED "AS IS" WITHOUT WARRANTY OF ANY KIND, EITHER EXPRESS OR IMPLIED, RELATING TO SALE AND/OR USE OF SKYWORKS™ PRODUCTS INCLUDING WARRANTIES RELATING TO FITNESS FOR A PARTICULAR PURPOSE, MERCHANTABILITY, PERFORMANCE, QUALITY OR NON-INFRINGEMENT OF ANY PATENT, COPYRIGHT OR OTHER INTELLECTUAL PROPERTY RIGHT. SKYWORKS FURTHER DOES NOT WARRANT THE ACCURACY OR COMPLETENESS OF THE INFORMATION, TEXT, GRAPHICS OR OTHER ITEMS CONTAINED WITHIN THESE MATERIALS. SKYWORKS SHALL NOT BE LIABLE FOR ANY SPECIAL, INDIRECT, INCIDENTAL, OR CONSEQUENTIAL DAMAGES, INCLUDING WITHOUT LIMITATION, LOST REVENUES OR LOST PROFITS THAT MAY RESULT FROM THE USE OF THESE MATERIALS.

Skyworks™ products are not intended for use in medical, lifesaving or life-sustaining applications. Skyworks' customers using or selling Skyworks™ products for use in such applications do so at their own risk and agree to fully indemnify Skyworks for any damages resulting from such improper use or sale.

The following are trademarks of Skyworks Solutions, Inc.: Skyworks™, the Skyworks symbol, and "Breakthrough Simplicity"™. Product names or services listed in this publication are for identification purposes only, and may be trademarks of third parties. Third-party brands and names are the property of their respective owners.

Additional information, posted at www.skyworksinc.com, is incorporated by reference.

General Information:
Skyworks Solutions, Inc.
4311 Jamboree Rd.
Newport Beach, CA. 92660-3007
www.skyworksinc.com

