

RM912

CDMA/AMPS 3–4 Volt Power Amplifier (824–849 MHz)

The RM912 dual mode Code Division Multiple Access (CDMA)/Advanced Mobile Phone Service (AMPS) Power Amplifier is a fully matched 6-pin LCC surface mount module designed for mobile units operating in the 824-849 MHz cellular bandwidth. This device meets stringent IS95 CDMA linearity requirements to beyond 28 dBm output power and can be driven to power output levels beyond 31 dBm for high efficiency FM mode operation. A single GaAs Microwave Monolithic Intergrated Circuit (MMIC) contains all active circuitry in the module. The MMIC contains on-board bias circuitry, as well as input and interstage matching circuits. The output match is realized off-chip within the module package to optimize efficiency and power performance into a 50 Ω load. This device is manufactured with Conexant's GaAs HBT process that provides for all positive voltage DC supply operation while maintaining high efficiency and good linearity. Primary bias to the RM912 can be supplied directly from a three cell nickel-cadmium, single cell lithium-ion, or other suitable battery with output in the 3-4 volt range. Power down is accomplished by setting the voltage on the low current reference pin to zero volts. No external supply side switch is needed as typical "off" leakage is a few microamperes with full primary voltage supplied from the battery.

Distinguishing Features

- Low voltage positive bias supply
- Good linearity
- High efficiency
- Dual mode operation
- Large dynamic range
- 6-pin LCC package (6 x 6 x 1.5 mm)
- Power down control

Applications

- Digital cellular (CDMA)
- Analog cellular (AMPS)
- Wireless local loop

Functional Block Diagram

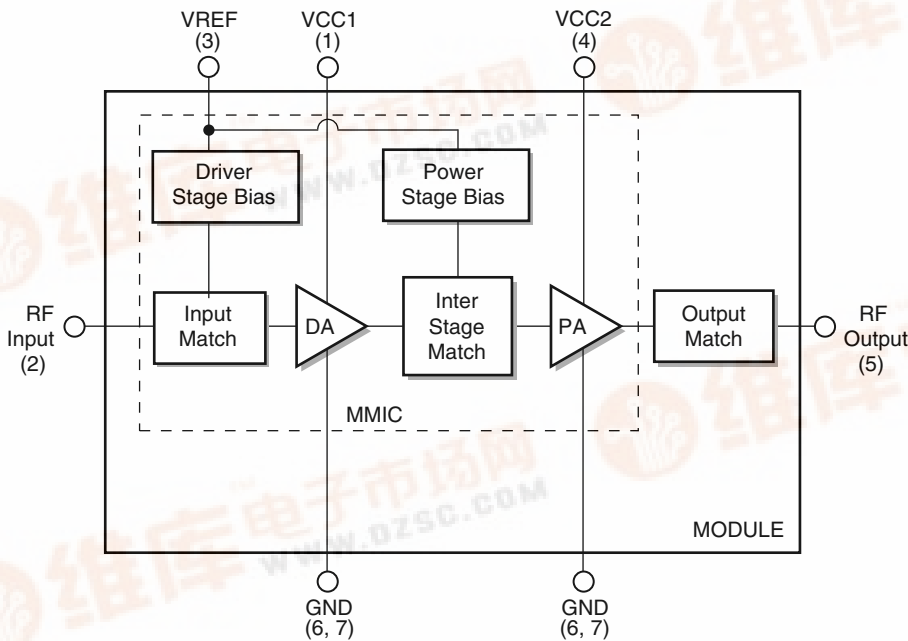

Electrical Specifications

The following tables list the electrical characteristics of the RM912 Power Amplifier. [Table 1](#) lists the absolute maximum rating for continuous operation. [Table 2](#) lists the recommended operating conditions for achieving the electrical performance listed in [Table 3](#). [Table 3](#) lists the electrical performance of the RM912 Power Amplifier over the recommended operating conditions.

Table 1. Absolute Maximum Ratings⁽¹⁾

Parameter	Symbol	Min	Nominal	Max	Unit
RF Input Power	Pin	—	3.0	6.0	dBm
Supply Voltage	Vcc	—	3.4	5.0	Volts
Reference Voltage	Vref	—	3.0	3.3	Volts
Case Operating Temperature	Tc	–30	25	+110	°C
Storage Temperature	Tstg	–55	—	+125	°C

NOTE(S):
⁽¹⁾ No damage assuming only one parameter is set at limit at a time with all other parameters set at or below nominal value.

Table 2. Recommended Operating Conditions

Parameter	Symbol	Min	Nominal	Max	Unit
Supply Voltage	Vcc	3.2	3.4	4.2	Volts
Reference Voltage	Vref	2.9	3.0	3.1	Volts
Operating Frequency	Fo	824.0	836.5	849.0	MHz
Operating Temperature	To	–30	+25	+85	°C

CDMA/AMPS 3–4 Volt Power Amplifier (824–849 MHz)

Table 3. Electrical Specifications for CDMA / AMPS Nominal Operating Conditions⁽¹⁾

Characteristics	Condition	Symbol	Min	Typical	Max	Unit
Quiescent current	Vref = 3.0	Iq	—	100.0	—	mA
	Vref = 2.9	Iq	—	80.0	—	mA
Gain–Digital	Po = 0 dBm	G	26.0	28.0	—	dB
	Po = 28 dBm	Gp	27.0	29.0	—	dB
Gain–Analog	Po = 0 dBm	G	26.0	28.0	—	dB
	Po = 31 dBm	Gp	26.0	28.0	—	dB
Power Added Efficiency						
	– Analog Mode	Po = 31 dBm	PAEa	43.0	45.0	—
– Digital Mode	Po = 28 dBm	PAEd	32.0	34.0	—	%
Adjacent Channel Power ⁽²⁾						
	– 885 kHz Offset	Po ≤ 28 dBm	ACP1	—	–50.0	–48.0
–1980 kHz Offset	Po ≤ 28 dBm	ACP2	—	–58.0	–56.0	dBc
Harmonic Suppression						
	– Second	Po ≤ 31 dBm	AFo2	—	–42.0	–30.0
– Third	Po ≤ 31 dBm	AFo3	—	–45.0	–30.0	dBc
Noise Power in RX Band 869-894 MHz	Po @ 28 dBm	RxBN	—	–134.0	–133.0	dBm/Hz
Noise Figure	—	NF	—	6.0	—	dB
Input Voltage Standing Wave Ratio	—	VSWR	—	1.4:1	—	—
Stability (Spurious output)	5:1 VSWR All phases	S	—	—	–60.0	dBc
Ruggedness – No damage	Po ≤ 31 dBm	Ru	10:1	—	—	VSWR
NOTE(S):						
(1) Vcc = +3.4 V, Vref = +3.0 V, Freq = 836.5 MHz, Tc = 25 °C, unless otherwise specified.						
(2) ACP is specified per IS95 as the ratio of the total in-band power (1.23 MHz BW) to adjacent power in a 30 kHz BW.						

Table 4. Electrical Specifications Limits for CDMA / AMPS Recommended Operating Conditions⁽¹⁾

Characteristics	Condition	Symbol	Min	Max	Unit
Quiescent current	Vref = 3.0	Iq	—	140.0	mA
Gain–Digital	Po = 0 dBm	G	25.0	29.0	dB
	Po = 28 dBm	Gp	25.0	32.0	dB
Gain–Analog	Po = 0 dBm	G	25.0	29.0	dB
	Po = 31dBm	Gp	24.0	32.0	dB
Power Added Efficiency	– Analog Mode Po = 31 dBm	PAEa	42.0	—	%
	– Digital Mode Po = 28 dBm	PAEd	32.0	—	%
Adjacent Channel Power ⁽²⁾	– 885 kHz Offset Po ≤ 28 dBm	ACP1	—	–44.0	dBc
	–1980 kHz Offset Po ≤ 28 dBm	ACP2	—	–56.0	dBc
Harmonic Suppression	– Second Po ≤ 31 dBm	AFo2	—	–40.0	dBc
	– Third Po ≤ 31 dBm	AFo3	—	–40.0	dBc
Noise Power in RX Band 869–894 MHz	Po @ 28 dBm	RxBN	—	–131.0	dBm/Hz
Input Voltage Standing Wave Ratio	—	VSWR	—	2:1	—
NOTE(S): (1) Per Table 2. (2) ACP is specified per IS95 as the ratio of the total in-band power (1.23 MHz BW) to adjacent power in a 30 kHz BW.					

Characterization Data

The following charts illustrate the characteristics of a typical RM912 Power Amplifier tested in the evaluation board described in the following section. The amplifier was selected by characterizing a group of devices and choosing a part with average electrical performance at both nominal and worst case (limit) conditions. Figures 1 through 4 illustrate the digital signal characteristics and Figures 5 through 8 illustrate the analog characteristics of the RM912.

Figure 1. Digital Gain vs. Output Power

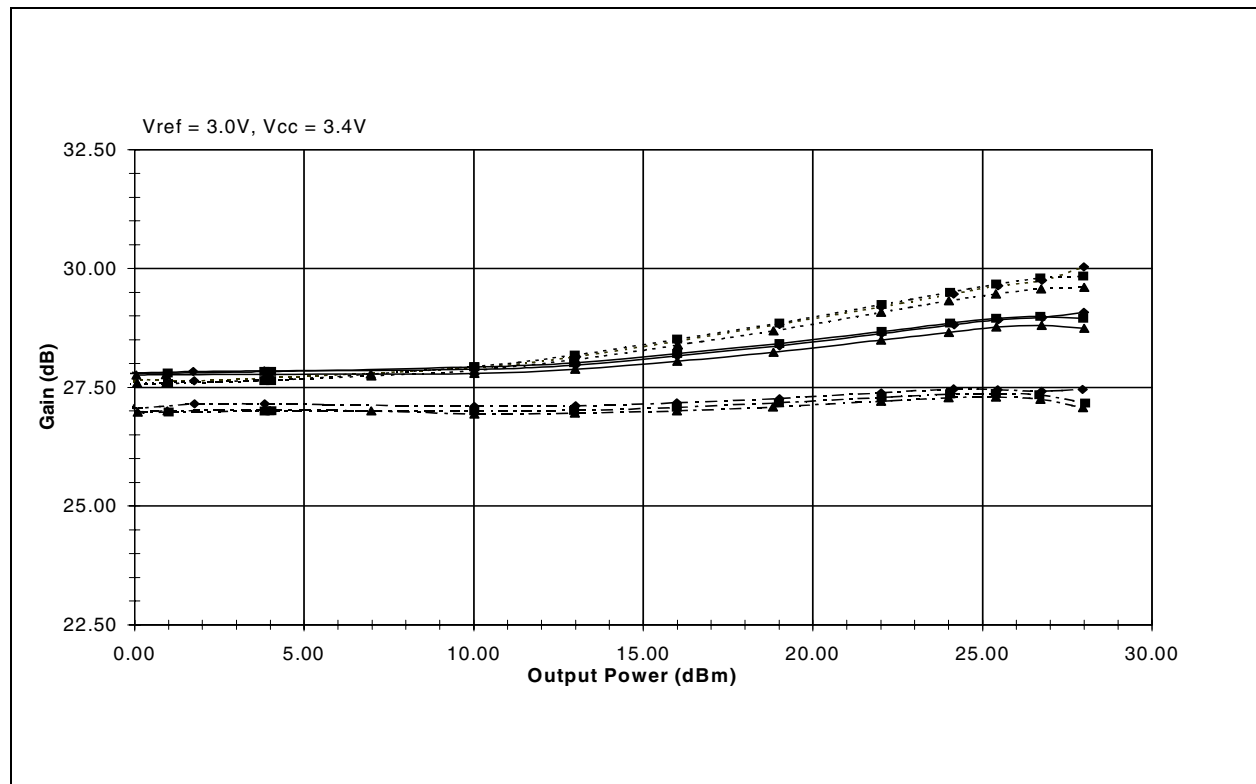

Legend

---◆---	824 MHz @ -30 °C	—◆—	824 MHz @ +25 °C	---◆---	824 MHz @ +85 °C
---■---	837 MHz @ -30 °C	—■—	837 MHz @ +25 °C	---■---	837 MHz @ +85 °C
---▲---	849 MHz @ -30 °C	—▲—	849 MHz @ +25 °C	---▲---	849 MHz @ +85 °C

Figure 2. Digital Adjacent Channel Power Magnitude (ACP1) vs. Output Power

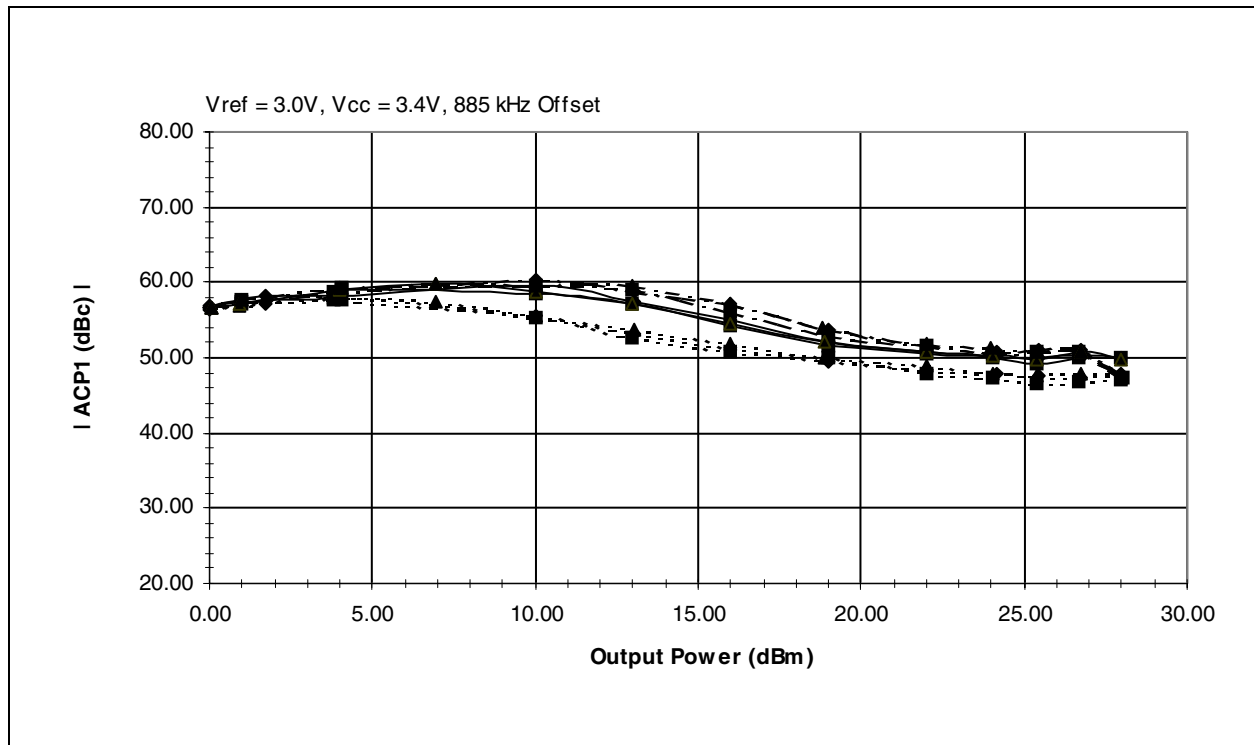
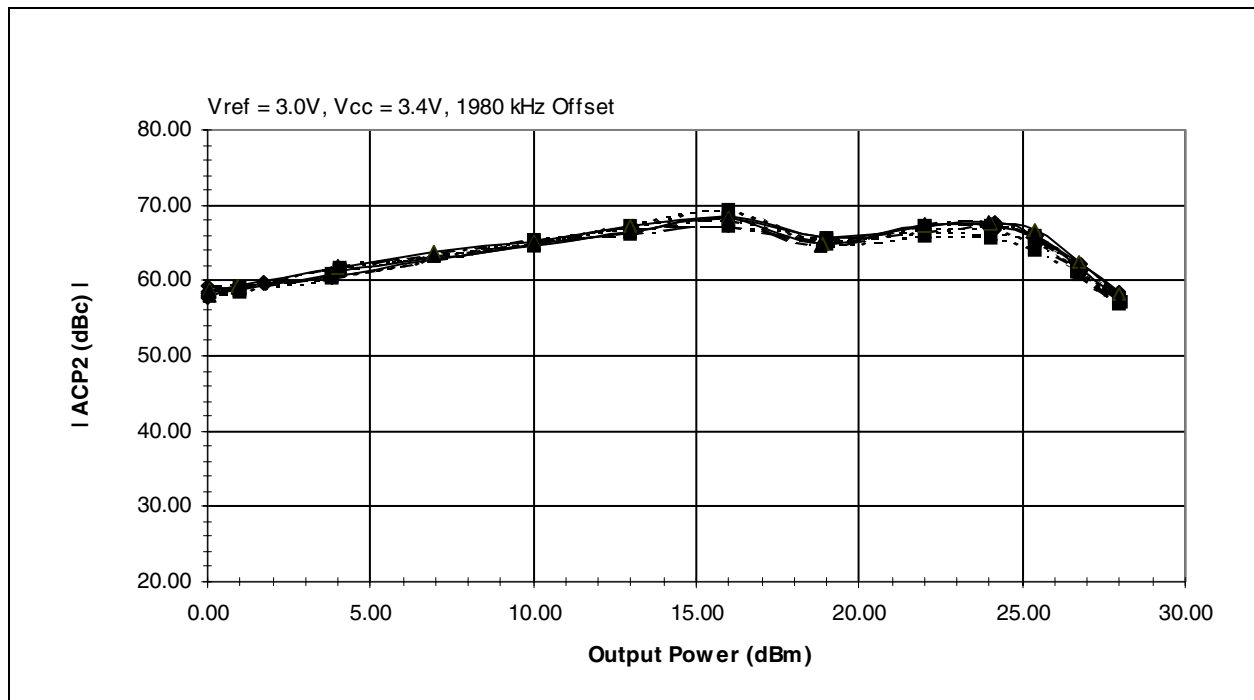

Figure 3. Digital Adjacent Channel Power Magnitude (ACP2) vs. Output Power



Legend

---◆---	824 MHz @ -30 °C	—◆—	824 MHz @ +25 °C	---◆---	824 MHz @ +85 °C
---■---	837 MHz @ -30 °C	—■—	837 MHz @ +25 °C	---■---	837 MHz @ +85 °C
---▲---	849 MHz @ -30 °C	—▲—	849 MHz @ +25 °C	---▲---	849 MHz @ +85 °C

CDMA/AMPS 3–4 Volt Power Amplifier (824–849 MHz)

Figure 4. Digital Power Added Efficiency vs. Output Power

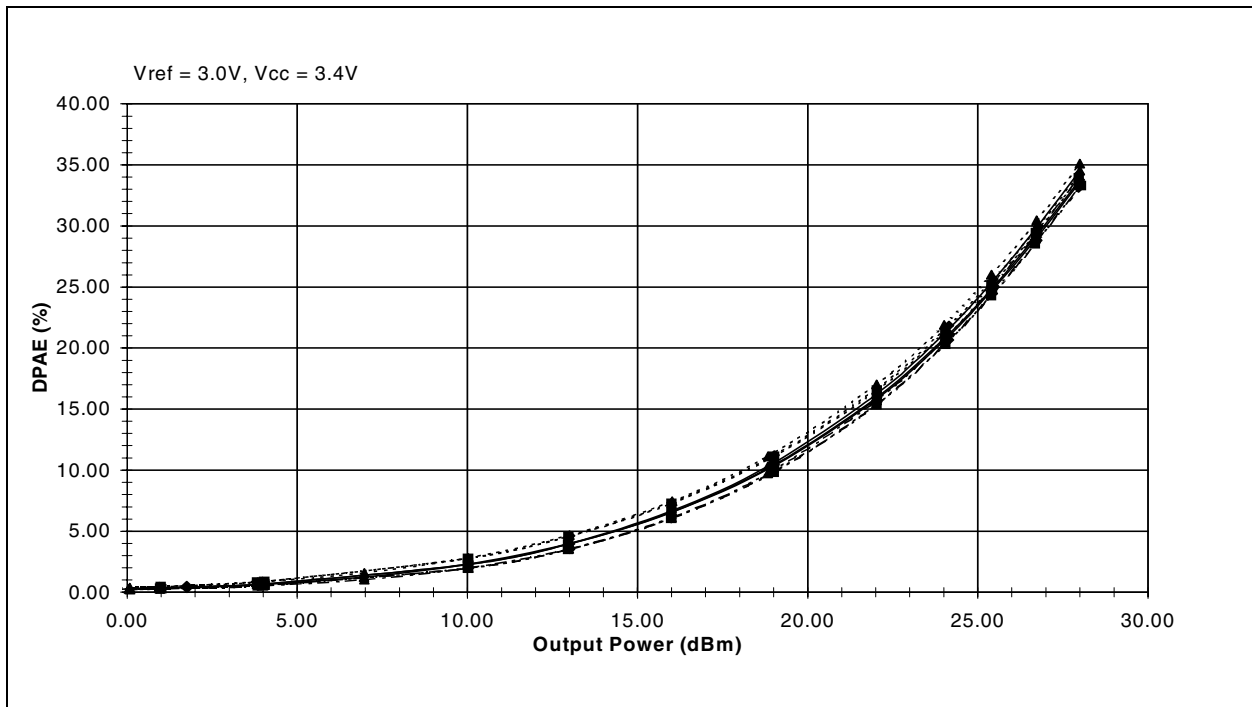
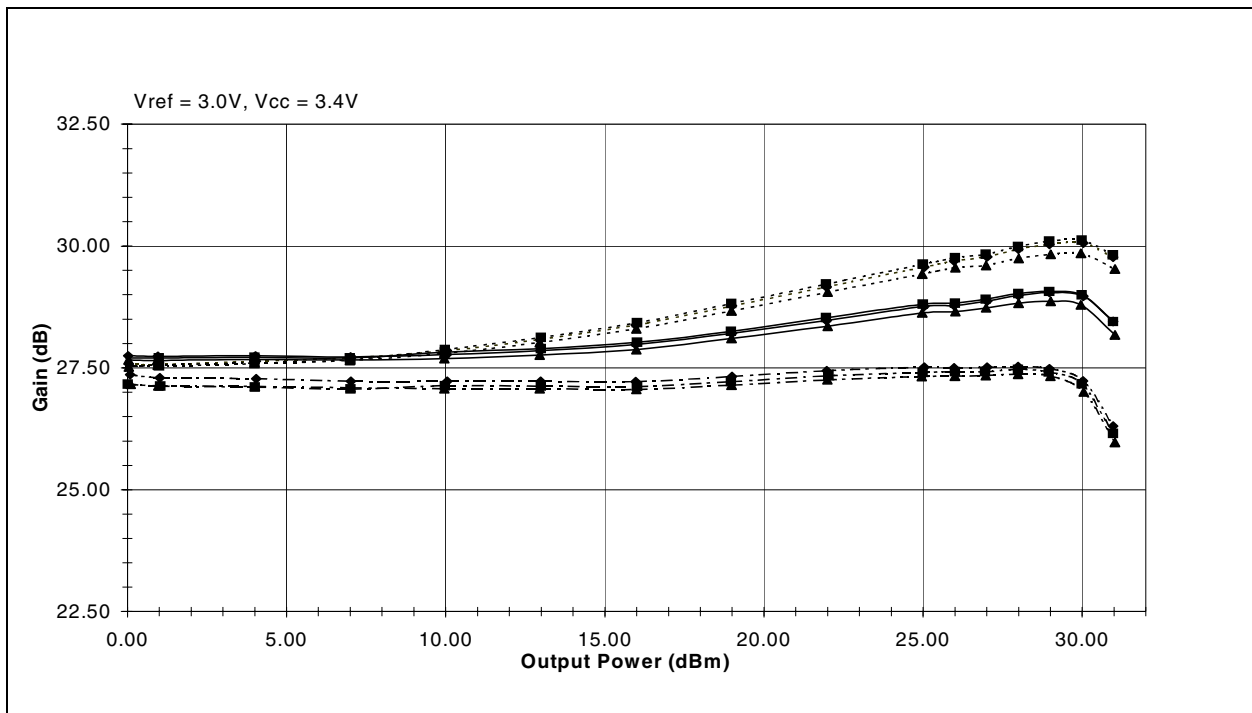

Figure 5. Analog Gain vs. Output Power



Legend

---◆---	824 MHz @ -30 °C	—◆—	824 MHz @ +25 °C	---◆---	824 MHz @ +85 °C
---■---	837 MHz @ -30 °C	—■—	837 MHz @ +25 °C	---■---	837 MHz @ +85 °C
---▲---	849 MHz @ -30 °C	—▲—	849 MHz @ +25 °C	---▲---	849 MHz @ +85 °C

Figure 6. Analog Power Added Efficiency vs. Output Power

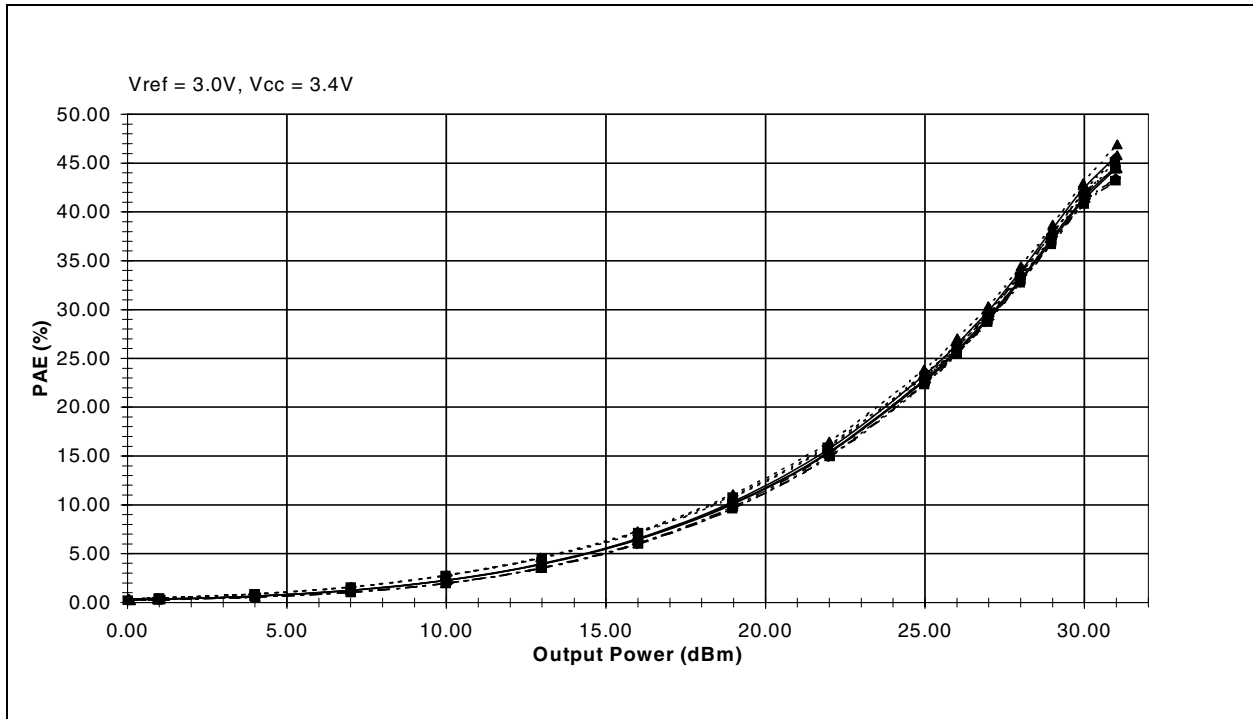
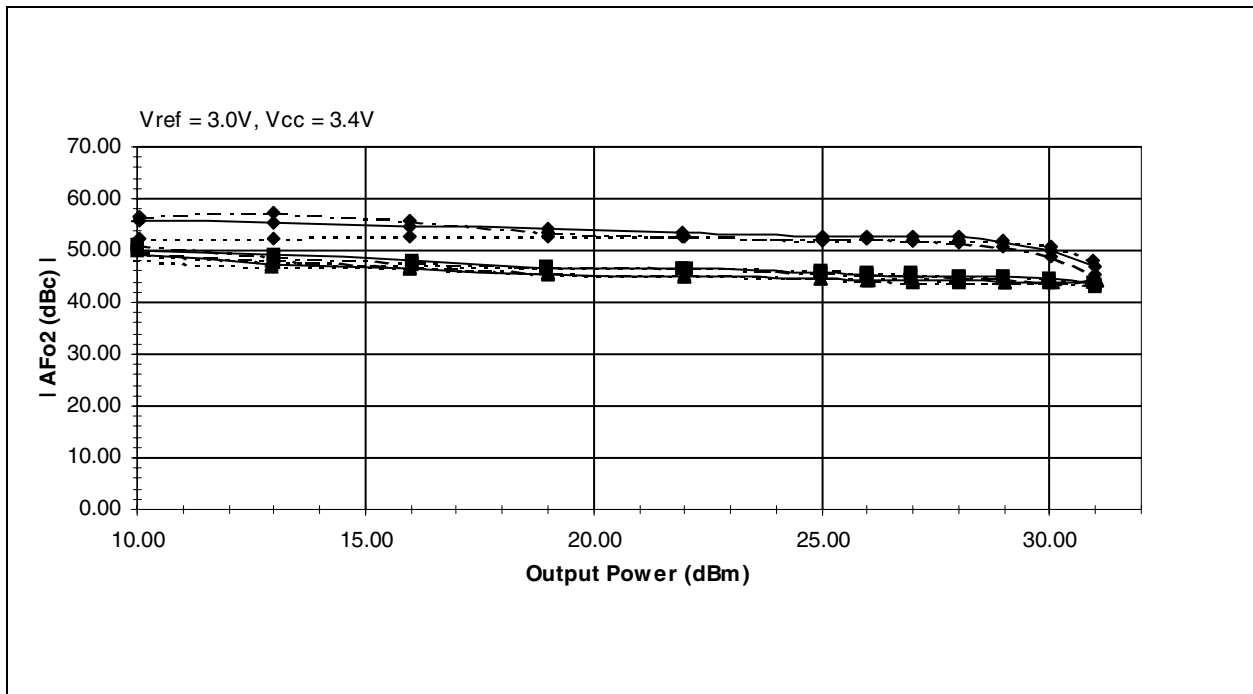

Figure 7. Analog Second Order Harmonic Suppression Magnitude



Legend

---◆---	824 MHz @ -30 °C	—◆—	824 MHz @ +25 °C	---◆---	824 MHz @ +85 °C
---■---	837 MHz @ -30 °C	—■—	837 MHz @ +25 °C	---■---	837 MHz @ +85 °C
---▲---	849 MHz @ -30 °C	—▲—	849 MHz @ +25 °C	---▲---	849 MHz @ +85 °C

CDMA/AMPS 3-4 Volt Power Amplifier (824-849 MHz)

Figure 8. Analog Third Order Harmonic Suppression Magnitude

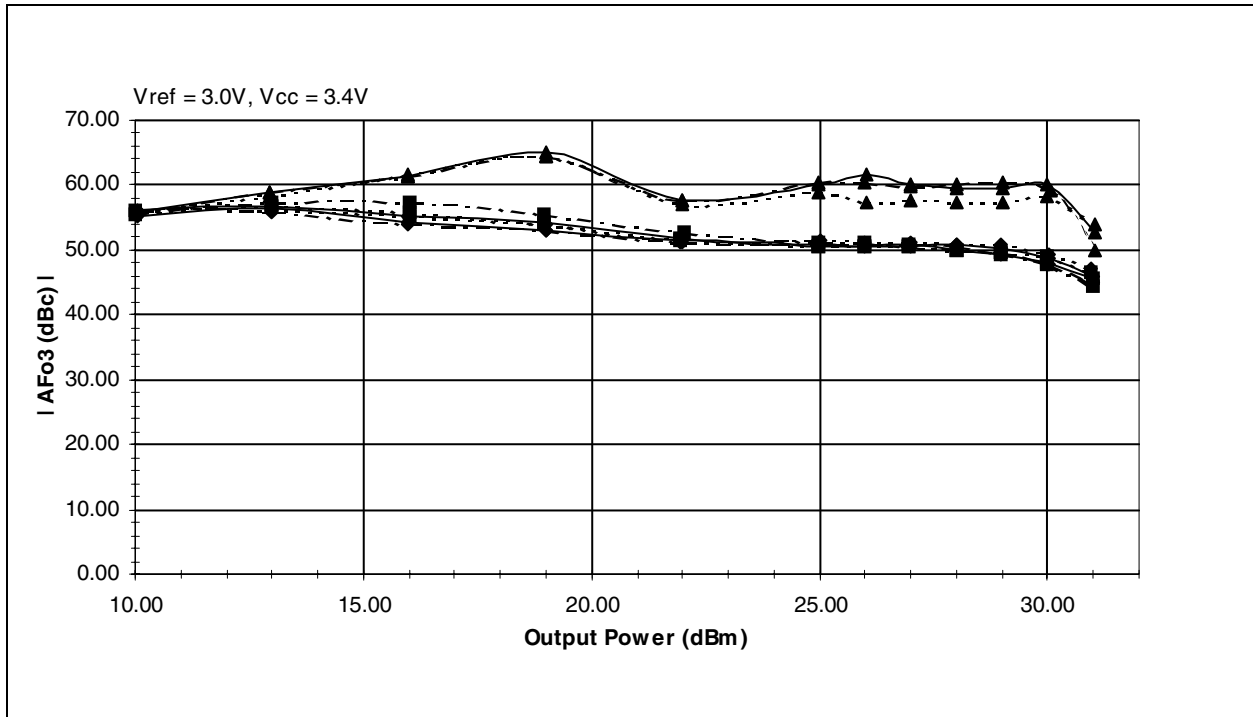

Legend

---◆---	824 MHz @ -30 °C	—◆—	824 MHz @ +25 °C	---◆--	824 MHz @ +85 °C
---■---	837 MHz @ -30 °C	—■—	837 MHz @ +25 °C	---■--	837 MHz @ +85 °C
---▲---	849 MHz @ -30 °C	—▲—	849 MHz @ +25 °C	---▲--	849 MHz @ +85 °C

Figure 9. Digital Gain vs. Output Power

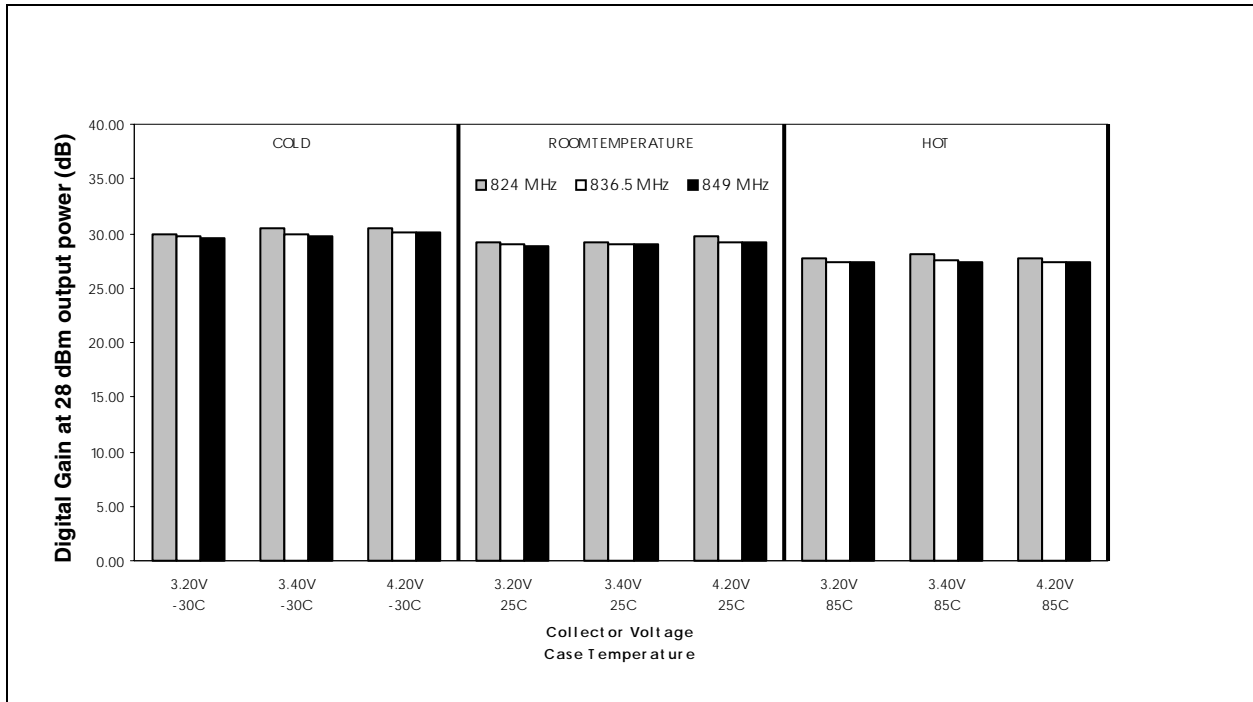
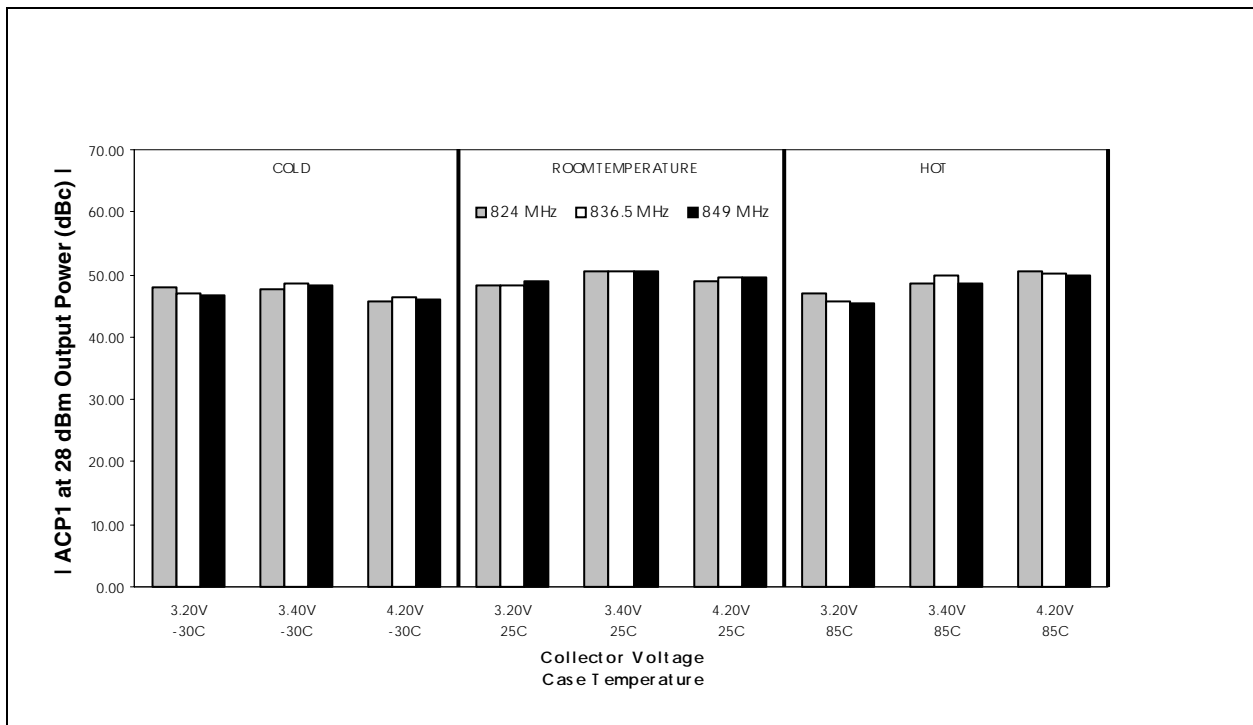

Figure 10. Digital Adjacent Channel Power Magnitude (ACP1) vs. Output Power



CDMA/AMPS 3–4 Volt Power Amplifier (824–849 MHz)

Figure 11. Digital Adjacent Channel Power Magnitude (ACP2) vs. Output Power

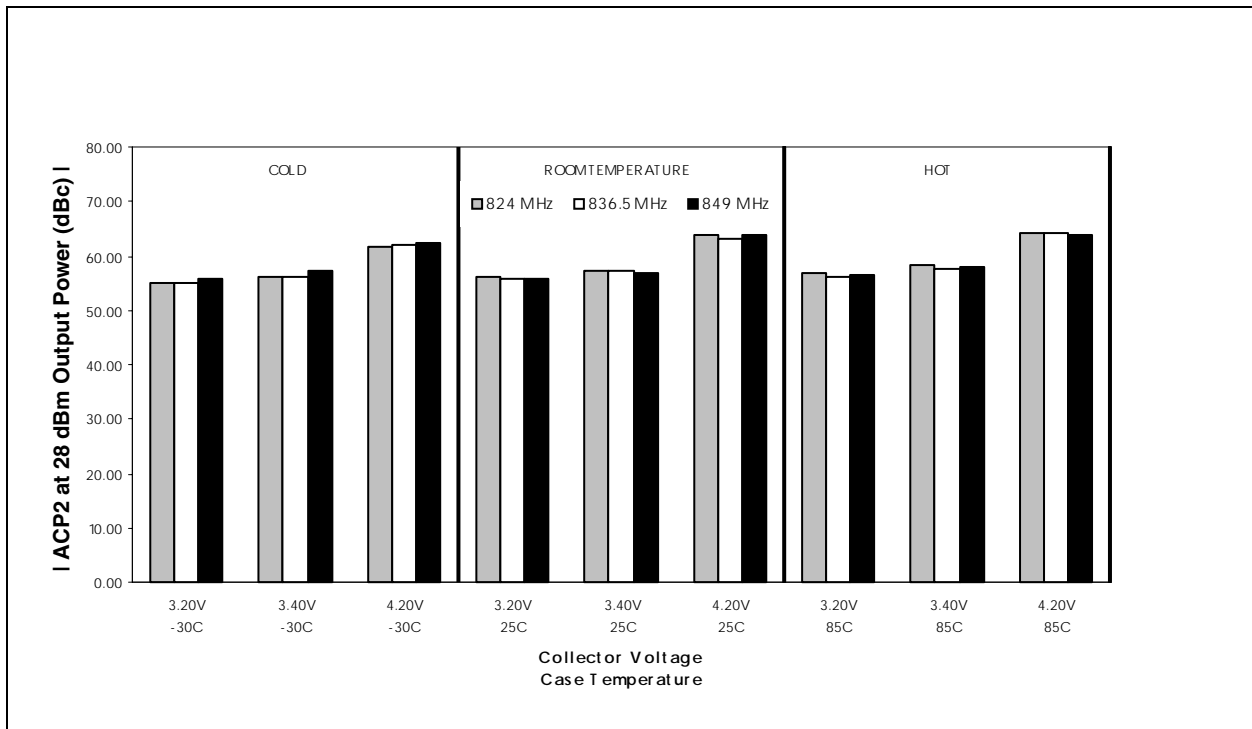

Figure 12. Analog Gain vs. Output Power

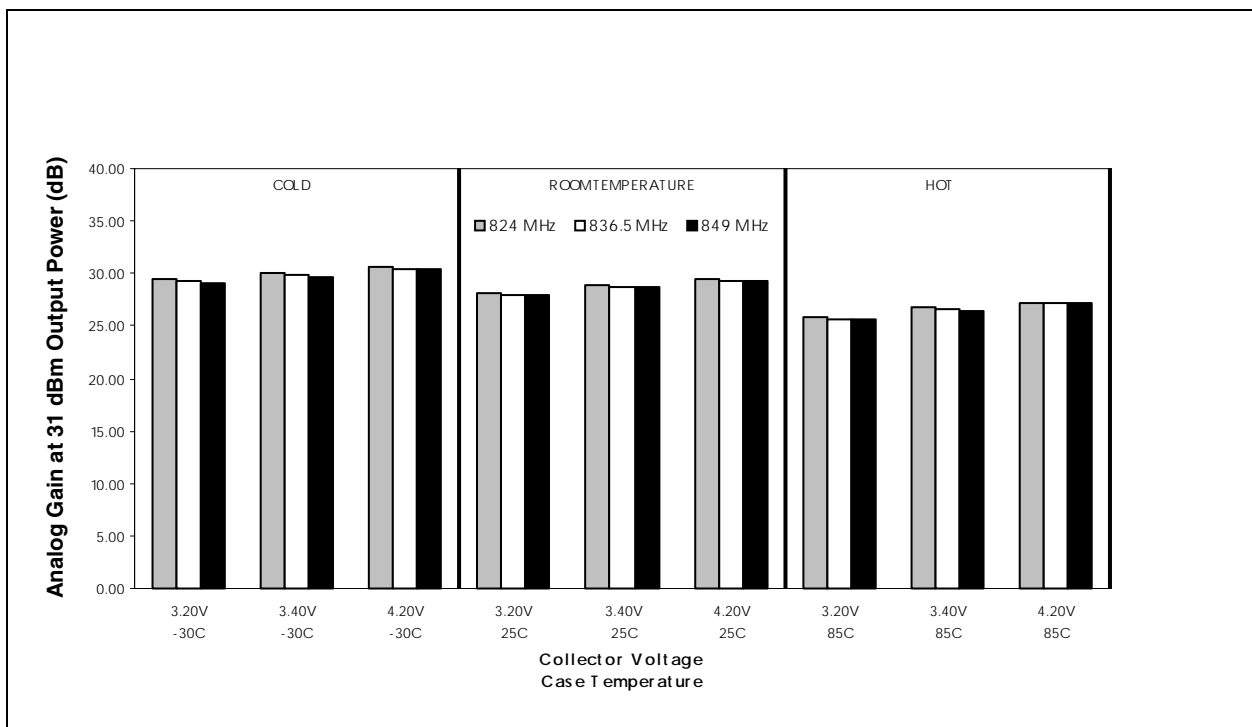

Figure 13. Analog Second Order Harmonic Suppression Magnitude

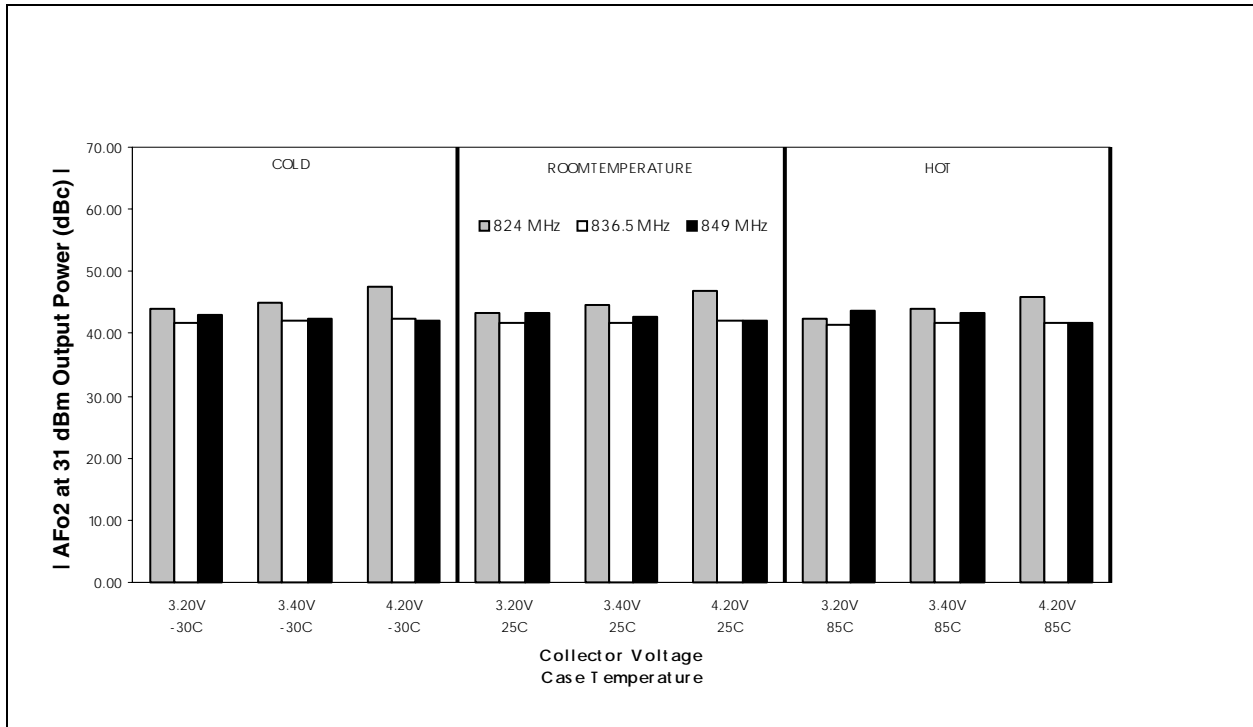
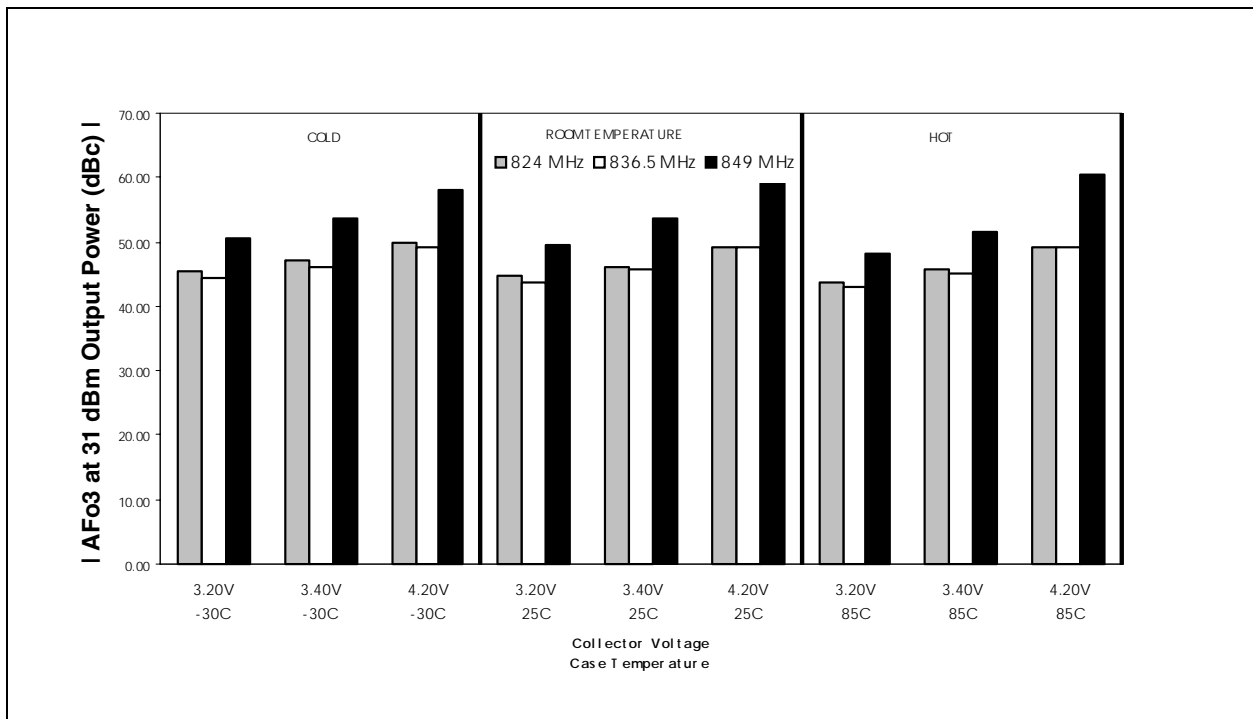

Figure 14. Analog Third Order Harmonic Suppression Magnitude



CDMA/AMPS 3–4 Volt Power Amplifier (824–849 MHz)

Figure 15. Noise Figure Variation Over Recommended Operating Conditions

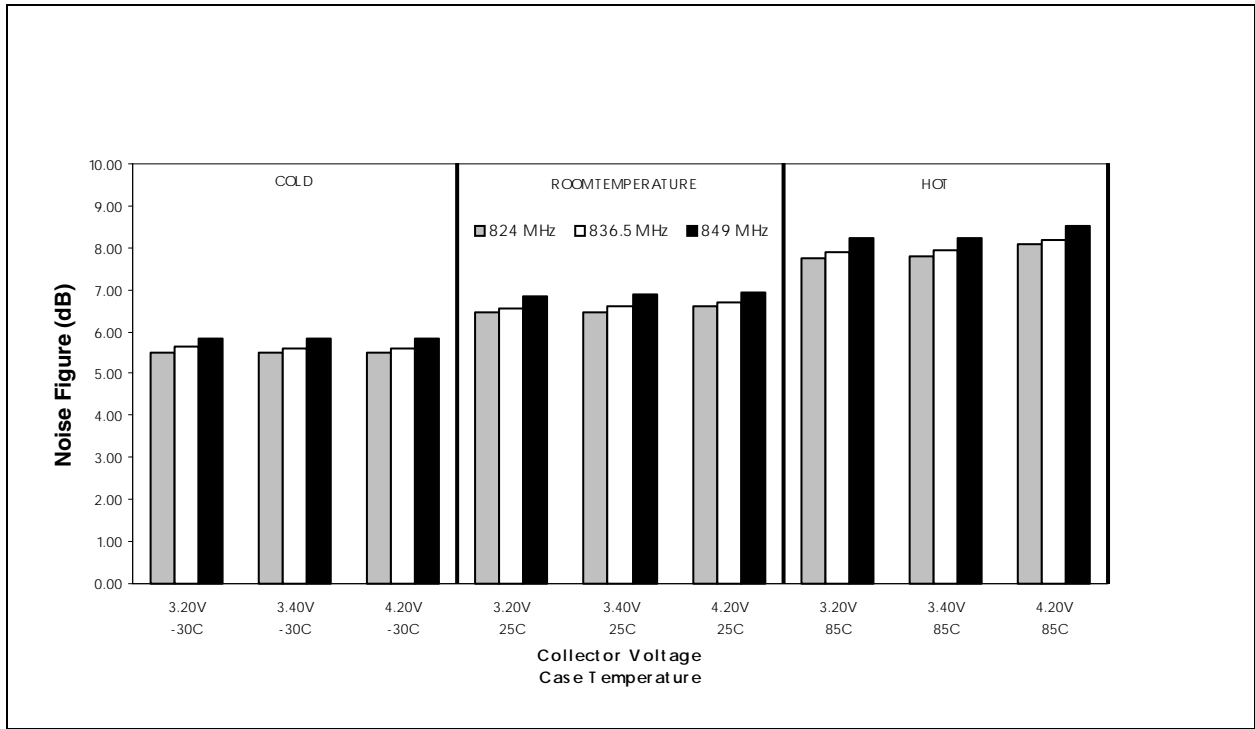
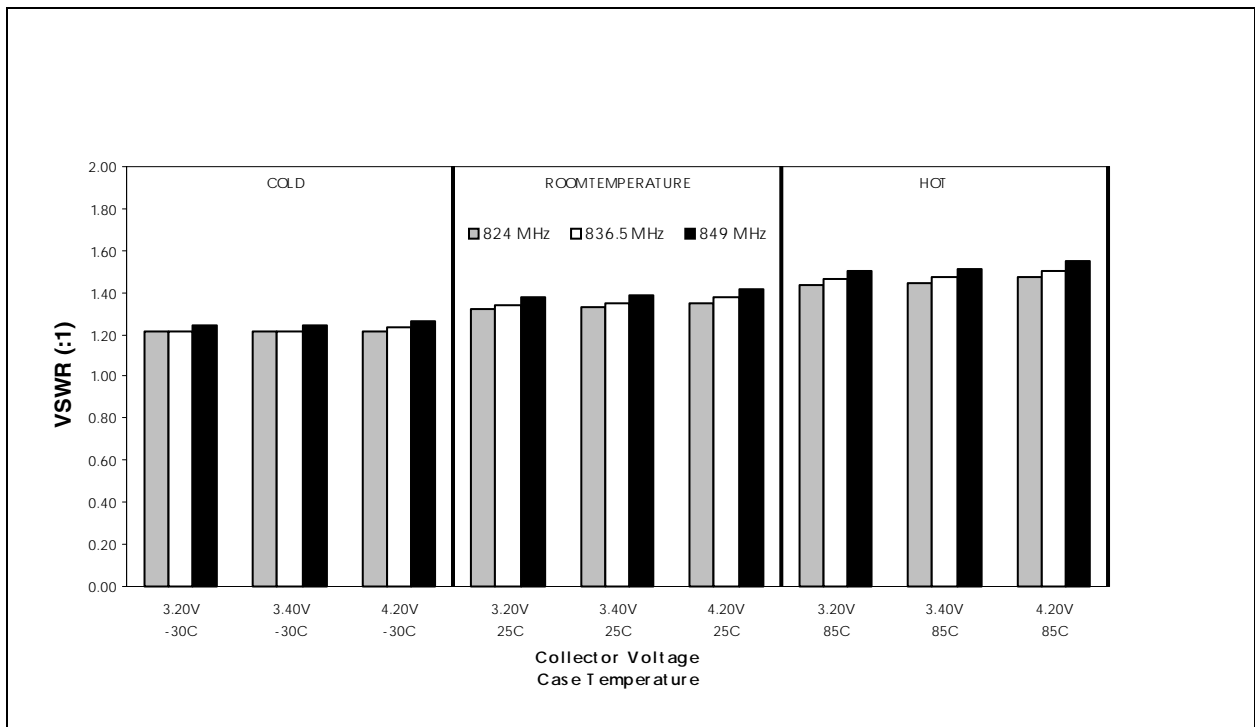

Figure 16. Voltage Standing Wave Ratio Variation Over Recommended Operating Conditions



Evaluation Board Description

The evaluation board is a platform for testing and interfacing design circuitry. To accommodate the interface testing of the RM912, the evaluation board schematic and diagrams are included for preliminary analysis and design. [Figure 17](#) shows the basic schematic of the board for the 824 MHz to 849 MHz range. [Figure 18](#) illustrates the board layout.

Figure 17. Evaluation Board Schematic

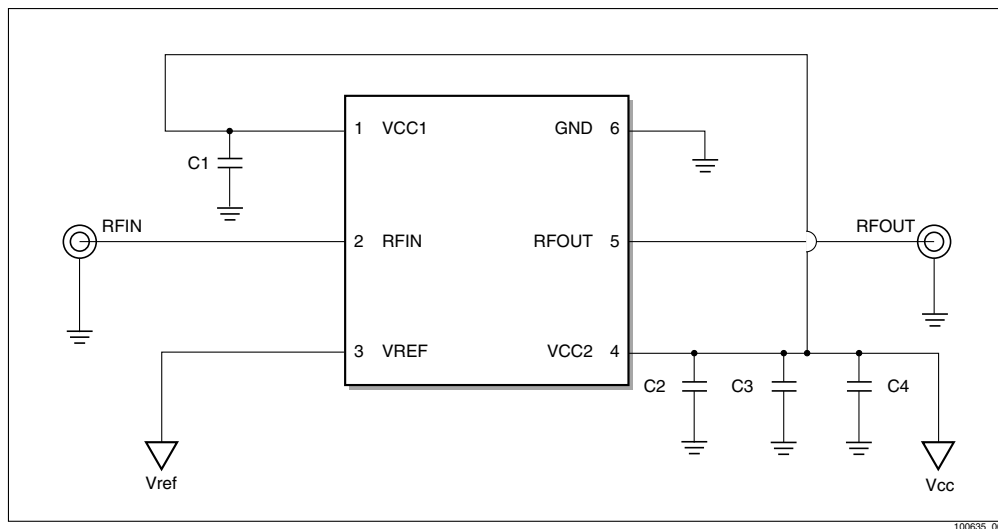
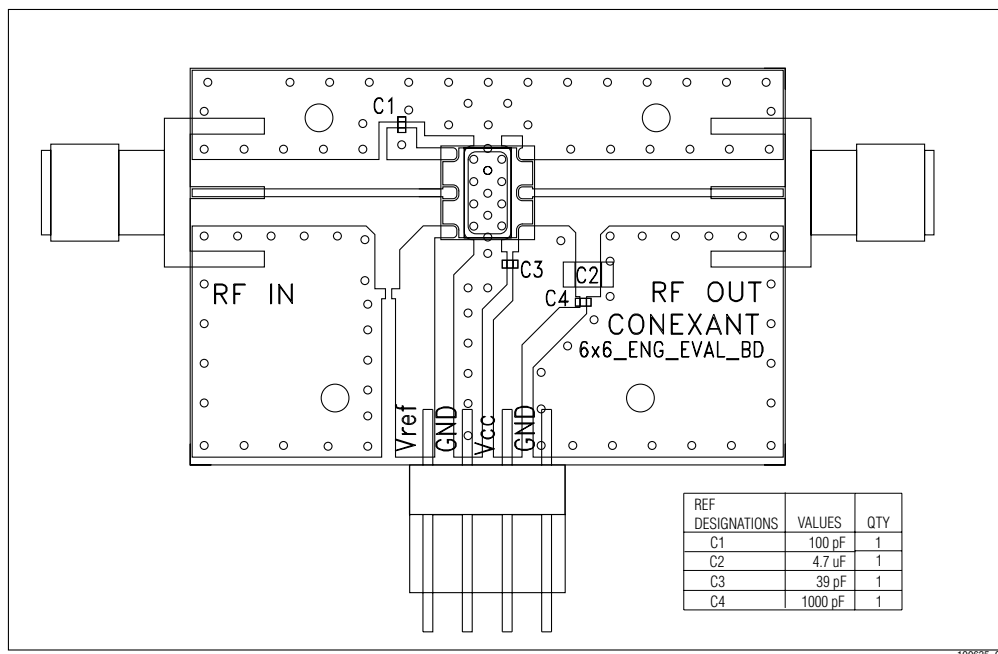

Figure 18. Evaluation Board Assembly Diagram



Package Dimensions and Pin Descriptions

The RM912 is a multi-layer laminate base, overmold encapsulated modular package designed for surface mount solder attachment to a printed circuit board.

Figure 19. RM912 Package Drawing

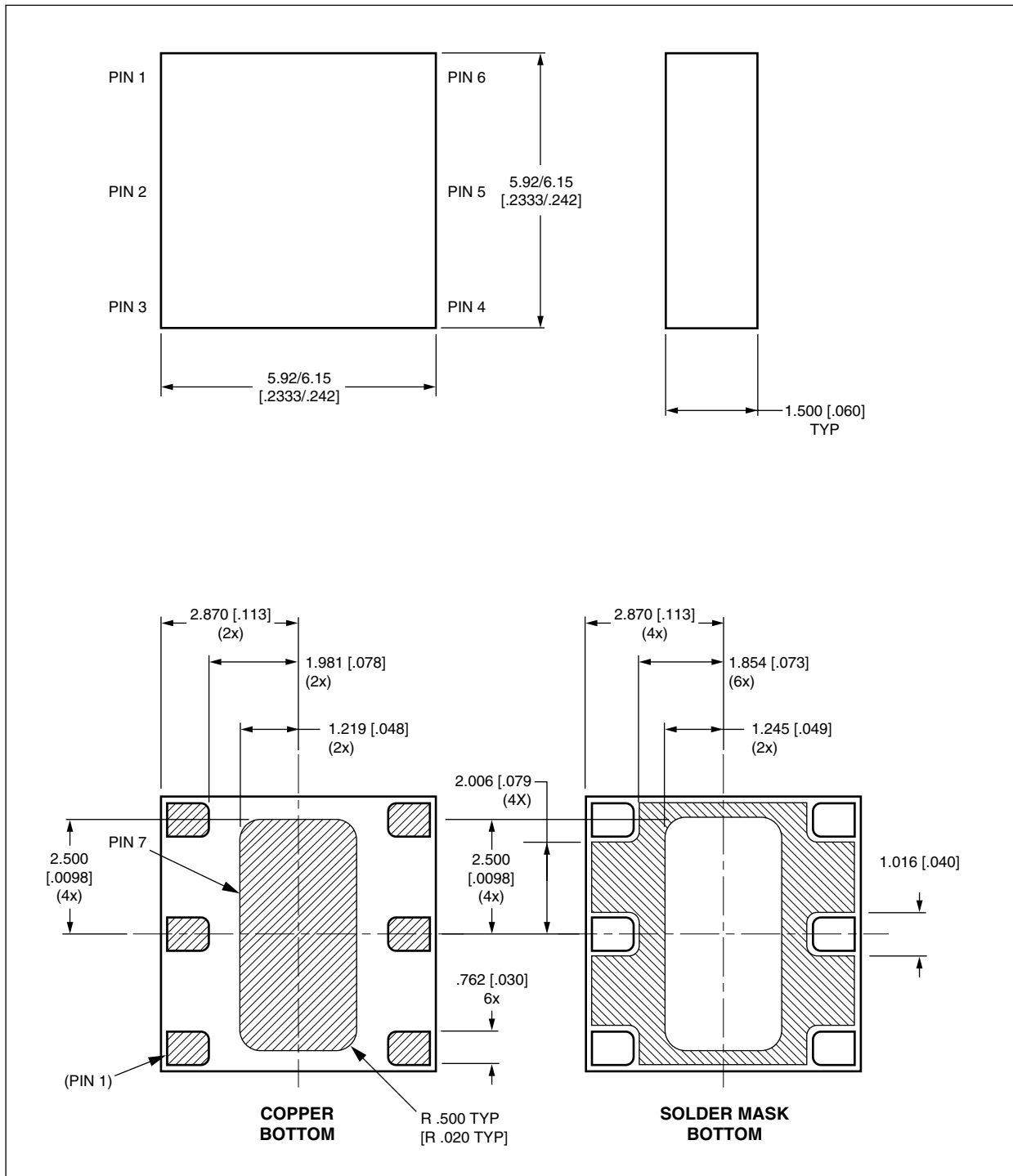
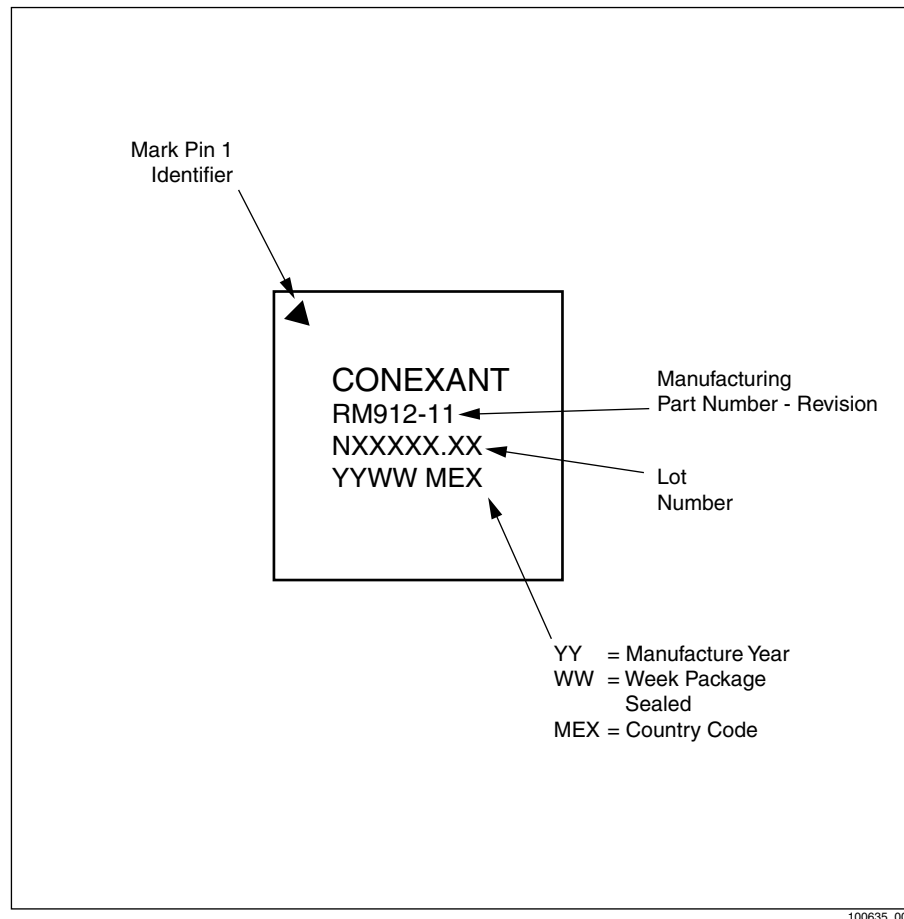

Table 5. Pin Description

Pin #	Function
1	VCC1 ⁽¹⁾
2	RF Input
3	VREF
4	VCC2 ⁽¹⁾
5	RF Output
6	GND
7	GND ⁽²⁾

NOTE(S):
 (1) All supply pins may be connected together at the supply.
 (2) Package underside is GND.

Figure 20. Typical Case Markings



CDMA/AMPS 3-4 Volt Power Amplifier (824-849 MHz)

Production quantities of this product are shipped in the standard tape-and-reel format illustrated below.

Figure 21. 6 x 6 Tape and Reel

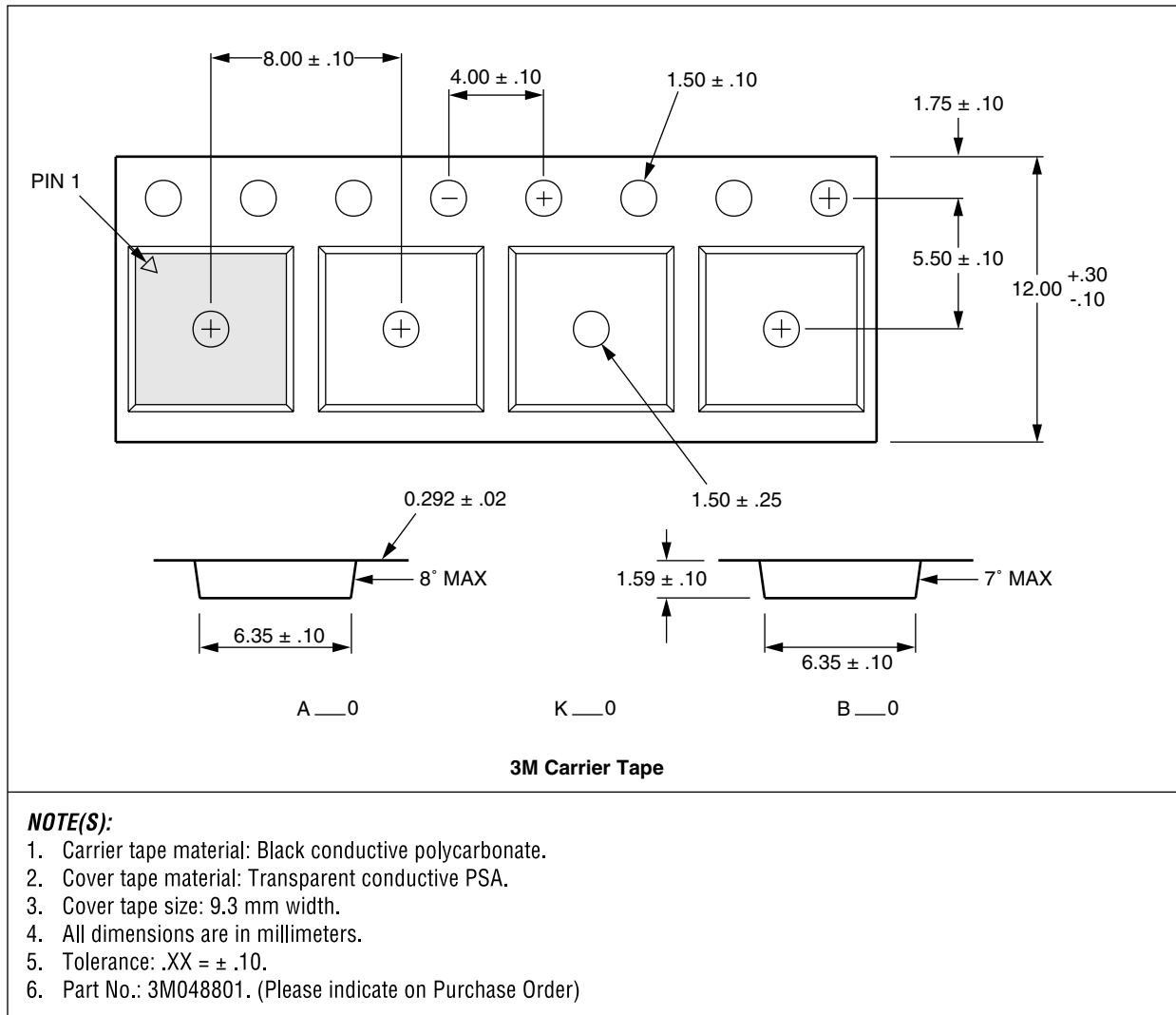

Electrostatic Discharge Sensitivity

The RM912 is a Class I device. Figure 22 lists the Electrostatic Discharge (ESD) immunity level for each pin of the RM912 product. The numbers in Figure 22 specify the ESD threshold level for each pin where the I-V curve between the pin and ground starts to show degradation. The ESD testing was performed in compliance with MIL-STD-883E Method 3015.7 using the Human Body Model. Since 2000 volts represents the maximum measurement limit of the test equipment used, pins marked > 2000 V pass 2000V ESD stress.

Figure 22. ESD Sensitivity Areas

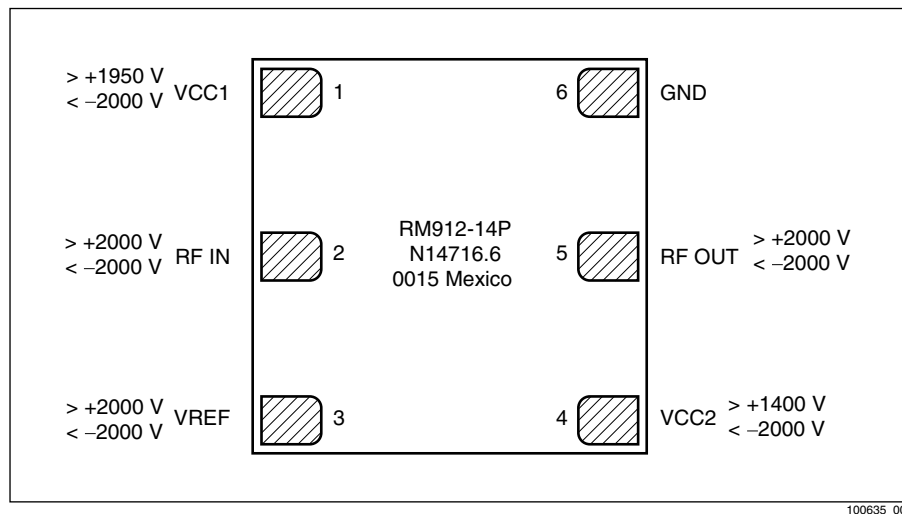

Various failure criteria can be utilized when performing ESD testing. Many vendors employ relaxed ESD failure standards which fail devices only after “the pin fails the electrical specification limits” or “the pin becomes completely non-functional”. Conexant employs most stringent criteria, fails devices as soon as the pin begins to show any degradation on a curve tracer.

To avoid ESD damage, latent or visible, it is very important the Class-1 ESD handling precautions listed in Table 6 be used in the product assembly and test areas follow.

Table 6. Precautions for GaAs ICs with ESD Thresholds Greater Than 200V But Less Than 2000V

<p style="text-align: center;"><u>Personnel Grounding</u></p> <p>Wrist Straps Conductive Smocks, Gloves and Finger Cots Antistatic ID Badges</p>	<p style="text-align: center;"><u>Facility</u></p> <p>Relative Humidity Control and Air Ionizers Dissipative Floors (less than 10⁹ Ω to GND)</p>
<p style="text-align: center;"><u>Protective Workstation</u></p> <p>Dissipative Table Tops Protective Test Equipment (Properly Grounded) Grounded Tip Soldering Irons Conductive Solder Suckers Static Sensors</p>	<p style="text-align: center;"><u>Protective Packaging & Transportation</u></p> <p>Bags and Pouches (Faraday Shield) Protective Tote Boxes (Conductive Static Shielding) Protective Trays Grounded Carts Protective Work Order Holders</p>

Ordering Information

Model Number	Manufacturing Part Number	Product Revision	Package	Operating Temperature
—	RM912	–14	6x6LM–6	–30 °C to +85 °C

Revision History

Revision	Level	Date	Description
A		March 2000	Preliminary Information
B		March 2000	Updated Preliminary Information
C		June 2000	Added Characterization Data, Released
D		July 2000	Updated ESD Data
E		July 2000	Preprint Update
F		August 2000	Web Site Update
G		August 2000	Web Format Corrections

Information in this document is provided in connection with Conexant Systems, Inc. (“Conexant”) products. These materials are provided by Conexant as a service to its customers and may be used for informational purposes only. Conexant assumes no responsibility for errors or omissions in these materials. Conexant may make changes to specifications and product descriptions at any time, without notice. Conexant makes no commitment to update the information and shall have no responsibility whatsoever for conflicts or incompatibilities arising from future changes to its specifications and product descriptions.

No license, express or implied, by estoppel or otherwise, to any intellectual property rights is granted by this document. Except as provided in Conexant’s Terms and Conditions of Sale for such products, Conexant assumes no liability whatsoever.

THESE MATERIALS ARE PROVIDED “AS IS” WITHOUT WARRANTY OF ANY KIND, EITHER EXPRESS OR IMPLIED, RELATING TO SALE AND/OR USE OF CONEXANT PRODUCTS INCLUDING LIABILITY OR WARRANTIES RELATING TO FITNESS FOR A PARTICULAR PURPOSE, CONSEQUENTIAL OR INCIDENTAL DAMAGES, MERCHANTABILITY, OR INFRINGEMENT OF ANY PATENT, COPYRIGHT OR OTHER INTELLECTUAL PROPERTY RIGHT. CONEXANT FURTHER DOES NOT WARRANT THE ACCURACY OR COMPLETENESS OF THE INFORMATION, TEXT, GRAPHICS OR OTHER ITEMS CONTAINED WITHIN THESE MATERIALS. CONEXANT SHALL NOT BE LIABLE FOR ANY SPECIAL, INDIRECT, INCIDENTAL, OR CONSEQUENTIAL DAMAGES, INCLUDING WITHOUT LIMITATION, LOST REVENUES OR LOST PROFITS, WHICH MAY RESULT FROM THE USE OF THESE MATERIALS.

Conexant products are not intended for use in medical, life saving or life sustaining applications. Conexant customers using or selling Conexant products for use in such applications do so at their own risk and agree to fully indemnify Conexant for any damages resulting from such improper use or sale.

The following are trademarks of Conexant Systems, Inc.: Conexant™, the Conexant C™ symbol, and “What’s Next in Communications Technologies”™. Product names or services listed in this publication are for identification purposes only, and may be trademarks of third parties. Third-party brands and names are the property of their respective owners.

For additional disclaimer information, please consult Conexant’s disclaimer information posted at www.conexant.com which is incorporated by reference.

Reader Response: Conexant strives to produce quality documentation and welcomes your feedback. Please send comments and suggestions to conexant.tech.pubs@conexant.com. For technical questions, contact your local Conexant [sales office](#) or field applications engineer.



Further Information:
literature@conexant.com
1-800-854-8099 (North America)
33-14-906-3980 (International)

Web Site
www.conexant.com

World Headquarters
Conexant Systems, Inc.
4311 Jamboree Road,
P.O. Box C
Newport Beach, CA 92658-8902
Phone: (949) 483-4600
Fax: (949) 483-6375

U.S. Florida/South America
Phone: (727) 799-8406
Fax: (727) 799-8306

U.S. Los Angeles
Phone: (805) 376-0559
Fax: (805) 376-8180

U.S. Mid-Atlantic
Phone: (215) 244-6784
Fax: (215) 244-9292

U.S. North Central
Phone: (630) 773-3454
Fax: (630) 773-3907

U.S. Northeast
Phone: (978) 692-7660
Fax: (978) 692-8185

U.S. Northwest/Pacific West
Phone: (408) 249-9696
Fax: (408) 249-7113

U.S. South Central
Phone: (972) 733-0723
Fax: (972) 407-0639

U.S. Southeast
Phone: (919) 858-9110
Fax: (919) 858-8669

U.S. Southwest
Phone: (949) 483-9119
Fax: (949) 483-9090

APAC Headquarters
Conexant Systems Singapore,
Pte. Ltd.
1 Kim Seng Promenade
Great World City
#09-01 East Tower
Singapore 237994
Phone: (65) 737 7355
Fax: (65) 737 9077

Australia
Phone: (61 2) 9869 4088
Fax: (61 2) 9869 4077

China
Phone: (86 2) 6361 2515
Fax: (86 2) 6361 2516

Hong Kong
Phone: (852) 2 827 0181
Fax: (852) 2 827 6488

India
Phone: (91 11) 692 4780
Fax: (91 11) 692 4712

Korea
Phone: (82 2) 565 2880
Fax: (82 2) 565 1440

Europe Headquarters
Conexant Systems France
Les Taissounieres B1
1681 Route des Dolines
BP 283
06905 Sophia Antipolis Cedex
France
Phone: (33 4) 93 00 33 35
Fax: (33 4) 93 00 33 03

Europe Central
Phone: (49 89) 829 1320
Fax: (49 89) 834 2734

Europe Mediterranean
Phone: (39 02) 9317 9911
Fax: (39 02) 9317 9913

Europe North
Phone: (44 1344) 486 444
Fax: (44 1344) 486 555

Europe South
Phone: (33 1) 41 44 36 50
Fax: (33 1) 41 44 36 90

Middle East Headquarters
Conexant Systems
Commercial (Israel) Ltd.
P.O. Box 12660
Herzlia 46733, Israel
Phone: (972 9) 952 4064
Fax: (972 9) 951 3924

Japan Headquarters
Conexant Systems Japan Co., Ltd.
Shimomoto Building
1-46-3 Hatsudai,
Shibuya-ku, Tokyo
151-0061 Japan
Phone: (81 3) 5371 1567
Fax: (81 3) 5371 1501

Taiwan Headquarters
Conexant Systems, Taiwan Co., Ltd.
Room 2808
International Trade Building
333 Keelung Road, Section 1
Taipei 110, Taiwan, ROC
Phone: (886 2) 2720 0282
Fax: (886 2) 2757 6760