

4-bit REAL TIME CLOCK MODULE

# RTC-62421/62423

- Built-in crystal unit allows adjustment-free efficient operation.
- Low standby voltage and current consumption (1.8μA at 2V).
- Wide range of operating temperature (from -40°C to +85°C).
- 24H/12H changeable and leap year automatically adjustable (gregorian calendar).
- Similar mounting method (RTC-62423) to that used for universal type SMD IC.
- Pins and functions are compatible with the MSM6242 series.

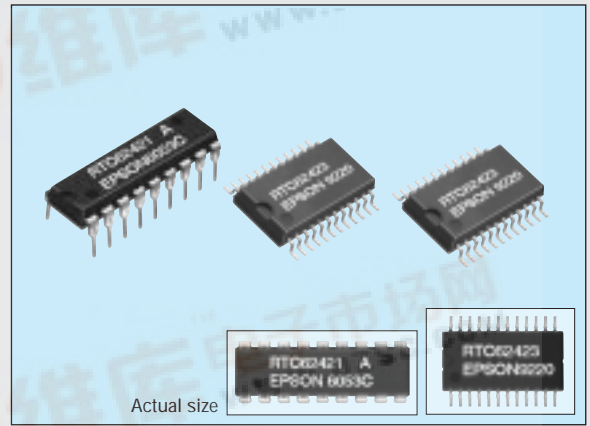

### Specifications (characteristics)

#### Absolute Max. rating

Item	Symbol	Condition	Specifications	Unit
Power source voltage	V <sub>DD</sub>	Ta=25°C	-0.3 to 7.0	V
Input and output voltage	V <sub>IO</sub>		-0.3 to V <sub>DD</sub> +0.3	
Storage temperature	T <sub>STG</sub>	RTC-62421	-55 to +85	°C
		RTC-62423	-55 to +125	
Soldering condition	T <sub>SOL</sub>	RTC-62421	Under 260°C within 10 sec. (lead part) (package should be less than 150°C)	
		RTC-62423	Twice at under 260°C within 10 sec. or under 230°C within 3 min.	

#### Operating range

Item	Symbol	Condition	Specifications	Unit
Operating voltage	V <sub>DD</sub>		4.5 to 5.5	V
Operating temperature	T <sub>OPR</sub>		-40 to +85	°C
Data holding voltage	V <sub>DH</sub>		2.0 to 5.5	V
CS <sub>1</sub> data holding time	t <sub>CDR</sub>	Refer to the data holding timing	2.0 min.	μs
Operation restoring time	t <sub>R</sub>			

#### Frequency characteristics and current consumption characteristics

Item	Symbol	Condition	Specifications	Unit	
Frequency tolerance	Δf/fo	Ta=25°C V <sub>DD</sub> =5V	62421 A	±10	ppm
			62421 B	±50	
			62423 A	±20	
			62423	±50	
Frequency temperature characteristics		-10 to +70°C (25°C reference temperature)	+10/-120		
		-40 to +85°C (25°C reference temperature)	+10/-220		
Aging	f <sub>a</sub>	V <sub>DD</sub> =5V, Ta=25°C, first year	±5 max.	ppm/Y	
Shock resistance	S.R.	Three drops on a hard board from 75 cm or 3000G x 0.3ms x 1/2 sine wave x 3 directions	±10 max.	ppm	
Current consumption	I <sub>DD1</sub>	CS <sub>1</sub> =0V	V <sub>DD</sub> =5V	30 max.	μA
	I <sub>DD2</sub>		V <sub>DD</sub> =2V	1.8 max.	

#### Electrical characteristics

Item	Symbol	Condition	Min.	Typ.	Max.	Unit	Applicable terminal
"H" input voltage (1)	V <sub>IH1</sub>	—	2.2	—	—	V	All inputs other than CS <sub>1</sub>
"L" input voltage (1)	V <sub>IL1</sub>						
Input leak current (1)	I <sub>LK1</sub>	V <sub>I</sub> =V <sub>DD</sub> /OV	—	—	1/-1	μA	Input other than Do to D <sub>3</sub>
Input leak current (2)	I <sub>LK2</sub>				10/-10		
"L" output voltage (1)	V <sub>OL1</sub>	I <sub>OL</sub> =2.5mA	2.4	—	0.4	V	Do to D <sub>3</sub>
"H" output voltage	V <sub>OH</sub>				I <sub>OH</sub> =-400μA		
"L" output voltage (2)	V <sub>OL2</sub>	I <sub>OL</sub> =2.5mA	—	—	0.4	V	STD.P
OFF leak current	I <sub>OFFLK</sub>				V <sub>I</sub> =V <sub>DD</sub> /OV		
Input capacity	C <sub>1</sub>	V <sub>I</sub> =V <sub>DD</sub> /OV input frequency 1 MHz	—	5	—	pF	
"H" input voltage (2)	V <sub>IH2</sub>	V <sub>DD</sub> =2 to 5.5V	—	—	4/5 V <sub>DD</sub>	V	CS <sub>1</sub>
"L" input voltage (2)	V <sub>IL2</sub>				1/5 V <sub>DD</sub>		

### Terminal connection

#### RTC-62421

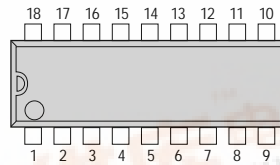

No.	62421	No.	62423
1	STD_P	1	STD_P
2	CS <sub>1</sub>	2	CS <sub>1</sub>
3	ALE	3	NC
4	A <sub>0</sub>	4	ALE
5	A <sub>1</sub>	5	A <sub>0</sub>
6	A <sub>2</sub>	6	NC
7	A <sub>3</sub>	7	A <sub>1</sub>
8	RD	8	NC
9	GND	9	A <sub>2</sub>
10	WR	10	A <sub>3</sub>
11	D <sub>2</sub>	11	RD
12	D <sub>2</sub>	12	GND
13	D <sub>1</sub>	13	WR
14	D <sub>0</sub>	14	D <sub>2</sub>
15	CS <sub>1</sub>	15	D <sub>2</sub>
16	(V <sub>DD</sub> )	16	D <sub>1</sub>
17	(V <sub>DD</sub> )	17	NC
18	V <sub>DD</sub>	18	NC
		19	D <sub>0</sub>
		20	CS <sub>1</sub>
		21	NC
		22	(V <sub>DD</sub> )
		23	(V <sub>DD</sub> )
		24	V <sub>DD</sub>

#### RTC-62423

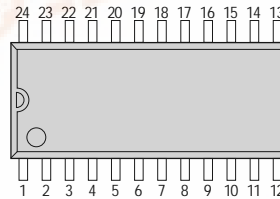

- (V<sub>DD</sub>) and V<sub>DD</sub> are to have the same level of voltage. Do not connect it to any external terminals.
- NC is not connected internally.

### External dimensions

(Unit: mm)

#### RTC-62421

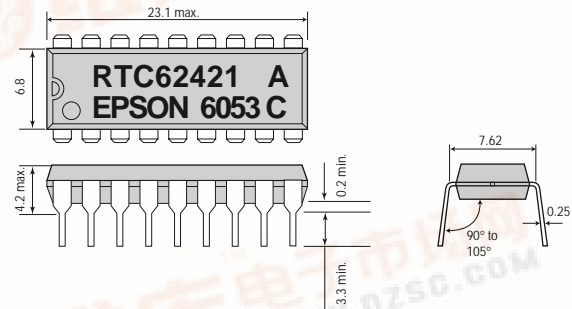

#### RTC-62423

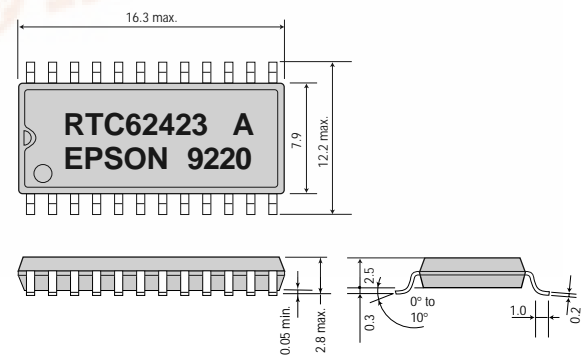

**Data holding timing**

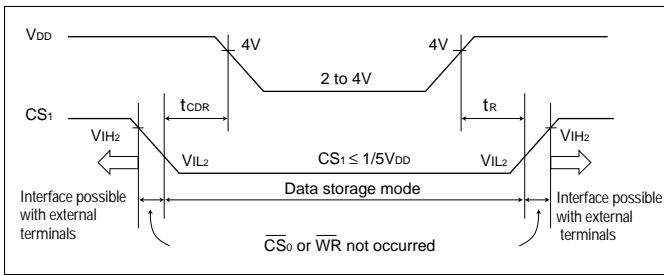

**Register table**

Address	A3	A2	A1	A0	Name of register	D3	D2	D1	D0	Count	Note
0	0	0	0	0	S <sub>1</sub>	s <sub>8</sub>	s <sub>4</sub>	s <sub>2</sub>	s <sub>1</sub>	0 to 9	1 - sec. digit register
1	0	0	0	1	S <sub>10</sub>	*	s <sub>40</sub>	s <sub>20</sub>	s <sub>10</sub>	0 to 5	10 - sec. digit register
2	0	0	1	0	M <sub>1</sub>	mi <sub>8</sub>	mi <sub>4</sub>	mi <sub>2</sub>	mi <sub>1</sub>	0 to 9	1 - min. digit register
3	0	0	1	1	M <sub>10</sub>	*	mi <sub>40</sub>	mi <sub>20</sub>	mi <sub>10</sub>	0 to 5	10 - min. digit register
4	0	1	0	0	H <sub>1</sub>	h <sub>8</sub>	h <sub>4</sub>	h <sub>2</sub>	h <sub>1</sub>	0 to 9	1 - hour digit register
5	0	1	0	1	H <sub>10</sub>	*	PM/AM	h <sub>20</sub>	H <sub>10</sub>	0 to 2 or 0 to 1	10 - hour digit register
6	0	1	1	0	D <sub>1</sub>	d <sub>8</sub>	d <sub>4</sub>	d <sub>2</sub>	d <sub>1</sub>	0 to 9	1 - day digit register
7	0	1	1	1	D <sub>10</sub>	*		d <sub>20</sub>	d <sub>10</sub>	0 to 3	10 - day digit register
8	1	0	0	0	MO <sub>1</sub>	mo <sub>8</sub>	mo <sub>4</sub>	mo <sub>2</sub>	mo <sub>1</sub>	0 to 9	1 - month digit register
9	1	0	0	1	MO <sub>10</sub>	*		mo <sub>10</sub>	mo <sub>10</sub>	0 to 1	10 - month digit register
A	1	0	1	0	Y <sub>1</sub>	y <sub>8</sub>	y <sub>4</sub>	y <sub>2</sub>	y <sub>1</sub>	0 to 9	1 - year digit register
B	1	0	1	1	Y <sub>10</sub>	y <sub>80</sub>	y <sub>40</sub>	y <sub>20</sub>	y <sub>10</sub>		10 - year digit register
C	1	1	0	0	W	*	w <sub>4</sub>	w <sub>2</sub>	w <sub>1</sub>	0 to 6	Week register
D	1	1	0	1	C <sub>D</sub>	30 sec. ADJ	IRQ FLAG	BUSY	HOLD		Control register D
E	1	1	1	0	C <sub>E</sub>	t <sub>1</sub>	t <sub>0</sub>	ITRPT /STND	MASK		Control register E
F	1	1	1	1	C <sub>F</sub>	TEST	24/12	STOP	RESET		Control register F

**Supplement**

0="L" level, 1="H" level

	PM/AM	24/12	ITRPT/STND
1	PM	24	ITRPT
0	AM	12	STND

Bit name	Description
* mark	Writable. Recognized as 0 while in read mode.
BUSY	Read only (effective only when HOLD=1)
IRQ FLAG	Enter "0" only when clearing interruption. Enter "1" otherwise.
24H/12H	Set able only when RESET=1
TEST	For our company's testing. TEST should be "0" in normal use.

Note: Do not enter erroneous data for clock. This may result in time keeping error.

**Block diagram**

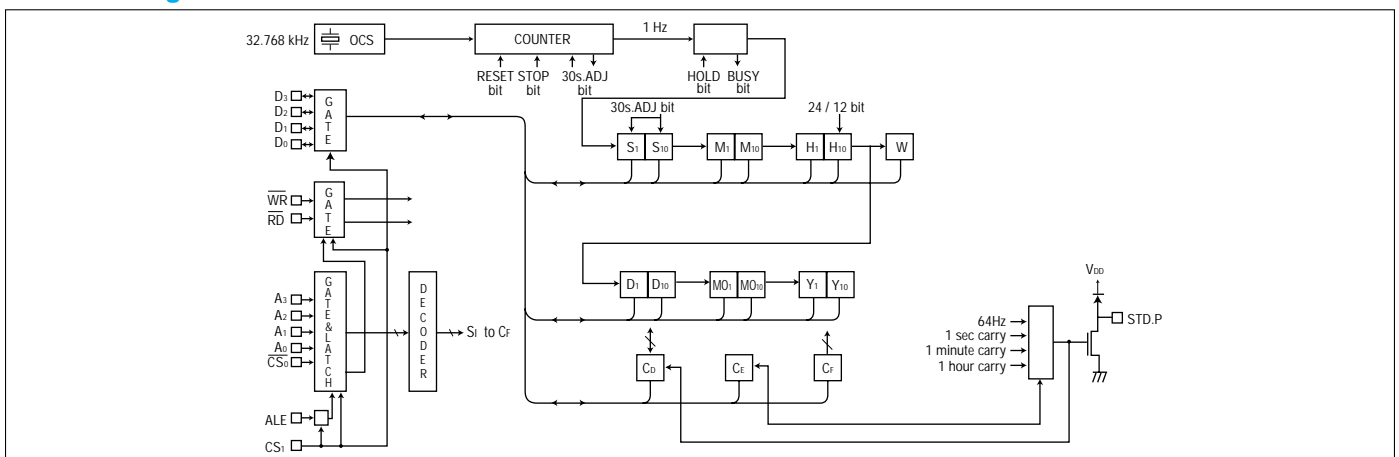

**Switching characteristics**

(V<sub>DD</sub> = 5V ± 0.5V, T<sub>a</sub> = -40 to +85°C)  
(ALE = While in use)

Item	Symbol	Condition	Min.	Max.	Unit
CS <sub>1</sub> setup time	t <sub>CIS</sub>	—	1000	—	ns
CS <sub>1</sub> hold time	t <sub>CIH</sub>		1000		
Address setup time	t <sub>AS</sub>		25		
Address hold time	t <sub>AH</sub>		25		
ALE pulse width	t <sub>AW</sub>		40		
ALE before WRITE	t <sub>ALW</sub>		10		
ALE before READ	t <sub>ALR</sub>		10		
ALE after WRITE	t <sub>WAL</sub>		20		
ALE after READ	t <sub>RAL</sub>		10		
WRITE pulse width	t <sub>WW</sub>		120		
R <sub>D</sub> to data	t <sub>RD</sub>	CL=150pF	—	120	
DATA hold	t <sub>DR</sub>	—	0	45	
DATA setup time	t <sub>DS</sub>		100		
DATA hold time	t <sub>DH</sub>		10		
R <sub>D</sub> /W <sub>R</sub> recovery time	t <sub>RCV</sub>	—	60	—	

**Write mode**

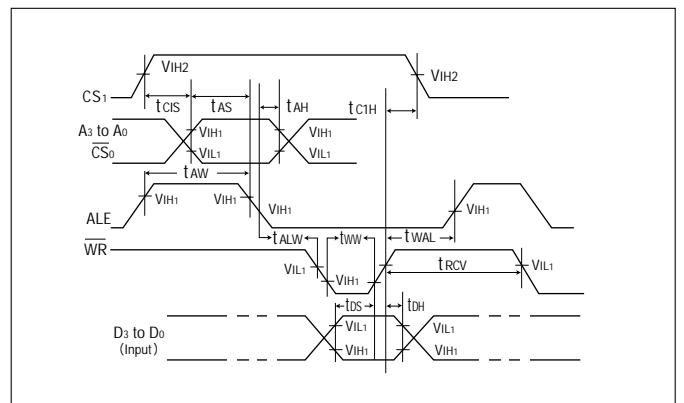

**Read mode**

