



# RURU15070, RURU15080, RURU15090, RURU150100

April 1995

150A, 700V - 1000V Ultrafast Diodes

## Features

- Ultrafast with Soft Recovery . . . . . <125ns
- Operating Temperature . . . . . +175°C
- Reverse Voltage Up To . . . . . 1000V
- Avalanche Energy Rated
- Planar Construction

## Applications

- Switching Power Supplies
- Power Switching Circuits
- General Purpose

## Description

RURU15070, RURU15080 and RURU15090 and RURU150100 are ultrafast diodes with soft recovery characteristics ( $t_{RR} < 125ns$ ). They have low forward voltage drop and are silicon nitride passivated ion-implanted epitaxial planar construction.

These devices are intended for use as freewheeling/clamping diodes and rectifiers in a variety of switching power supplies and other power switching applications. Their low stored charge and ultrafast recovery with soft recovery characteristic minimizes ringing and electrical noise in many power switching circuits reducing power loss in the switching transistors.

### PACKAGING AVAILABILITY

PART NUMBER	PACKAGE	BRAND
RURU15070	TO-218	RURU15070
RURU15080	TO-218	RURU15080
RURU15090	TO-218	RURU15090
RURU150100	TO-218	RUR150100

NOTE: When ordering, use the entire part number.

## Package

JEDEC STYLE SINGLE LEAD TO-218

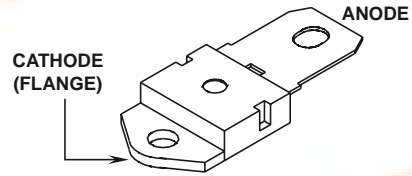

## Symbol



## Absolute Maximum Ratings $T_C = +25^\circ C$ , Unless Otherwise Specified

	RURU15070	RURU15080	RURU15090	RURU150100	UNITS
Peak Repetitive Reverse Voltage . . . . . $V_{RRM}$	700	800	900	1000	V
Working Peak Reverse Voltage . . . . . $V_{RWM}$	700	800	900	1000	V
DC Blocking Voltage . . . . . $V_R$	700	800	900	1000	V
Average Rectified Forward Current . . . . . $I_{F(AV)}$ ( $T_C = +65^\circ C$ )	150	150	150	150	A
Repetitive Peak Surge Current . . . . . $I_{FSM}$ (Square Wave, 20kHz)	300	300	300	300	A
Nonrepetitive Peak Surge Current . . . . . $I_{FSM}$ (Halfwave, 1 Phase, 60Hz)	1500	1500	1500	1500	A
Maximum Power Dissipation . . . . . $P_D$	375	375	375	375	W
Avalanche Energy (L = 40mH) . . . . . $E_{AVL}$	50	50	50	50	mJ
Operating and Storage Temperature . . . . . $T_{STG}, T_J$	-65 to +175	-65 to +175	-65 to +175	-65 to +175	$^\circ C$

## Specifications RURU15070, RURU15080, RURU15090, RURU150100

**Electrical Specifications**  $T_C = +25^\circ\text{C}$ , Unless Otherwise Specified

SYMBOL	TEST CONDITION	LIMITS												UNITS
		RURU15070			RURU15080			RURU15090			RURU150100			
		MIN	TYP	MAX	MIN	TYP	MAX	MIN	TYP	MAX	MIN	TYP	MAX	
$V_F$	$I_F = 150\text{A}, T_C = +25^\circ\text{C}$	-	-	1.9	-	-	1.9	-	-	1.9	-	-	1.9	V
$V_F$	$I_F = 150\text{A}, T_C = +150^\circ\text{C}$	-	-	1.7	-	-	1.7	-	-	1.7	-	-	1.7	V
$I_R$	$V_R = 700\text{V}, T_C = +25^\circ\text{C}$	-	-	500	-	-	-	-	-	-	-	-	-	$\mu\text{A}$
	$V_R = 800\text{V}, T_C = +25^\circ\text{C}$	-	-	-	-	-	500	-	-	-	-	-	-	$\mu\text{A}$
	$V_R = 900\text{V}, T_C = +25^\circ\text{C}$	-	-	-	-	-	-	-	-	500	-	-	-	$\mu\text{A}$
	$V_R = 1000\text{V}, T_C = +25^\circ\text{C}$	-	-	-	-	-	-	-	-	-	-	-	500	$\mu\text{A}$
$I_R$	$V_R = 700\text{V}, T_C = +150^\circ\text{C}$	-	-	3.0	-	-	-	-	-	-	-	-	-	mA
	$V_R = 800\text{V}, T_C = +150^\circ\text{C}$	-	-	-	-	-	3.0	-	-	-	-	-	-	mA
	$V_R = 900\text{V}, T_C = +150^\circ\text{C}$	-	-	-	-	-	-	-	-	3.0	-	-	-	mA
	$V_R = 1000\text{V}, T_C = +150^\circ\text{C}$	-	-	-	-	-	-	-	-	-	-	-	3.0	mA
$t_{RR}$	$I_F = 1\text{A}, di_F/dt = 100\text{A}/\mu\text{s}$	-	-	125	-	-	125	-	-	125	-	-	125	ns
	$I_F = 150\text{A}, di_F/dt = 100\text{A}/\mu\text{s}$	-	-	200	-	-	200	-	-	200	-	-	200	ns
$t_A$	$I_F = 150\text{A}, di_F/dt = 100\text{A}/\mu\text{s}$	-	100	-	-	100	-	-	100	-	-	100	-	ns
$t_B$	$I_F = 150\text{A}, di_F/dt = 100\text{A}/\mu\text{s}$	-	75	-	-	75	-	-	75	-	-	75	-	ns
$R_{\theta JC}$		-	-	0.4	-	-	0.4	-	-	0.4	-	-	0.4	$^\circ\text{C}/\text{W}$

### DEFINITIONS

$V_F$  = Instantaneous forward voltage ( $p_w = 300\mu\text{s}$ ,  $D = 2\%$ ).

$I_R$  = Instantaneous reverse current.

$t_{RR}$  = Reverse recovery time (See Figure 2), summation of  $t_A + t_B$ .

$t_A$  = Time to reach peak reverse current (See Figure 2).

$t_B$  = Time from peak  $I_{RM}$  to projected zero crossing of  $I_{RM}$  based on a straight line from peak  $I_{RM}$  through 25% of  $I_{RM}$  (See Figure 2).

$R_{\theta JC}$  = Thermal resistance junction to case.

$E_{AVL}$  = Controlled avalanche energy (See Figures 7 and 8).

$p_w$  = pulse width.

$D$  = duty cycle.

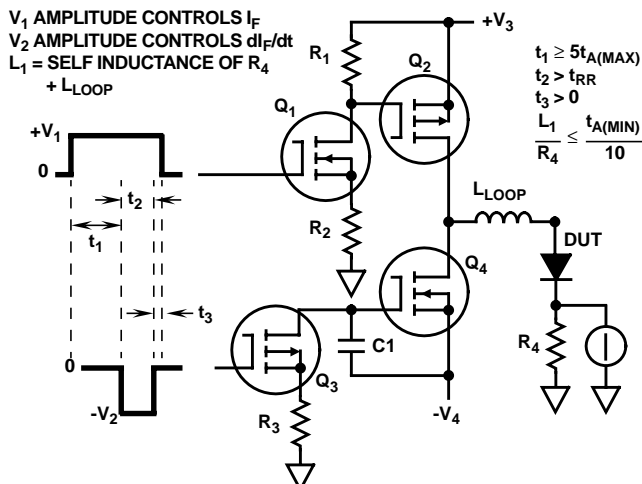

FIGURE 1.  $t_{RR}$  TEST CIRCUIT

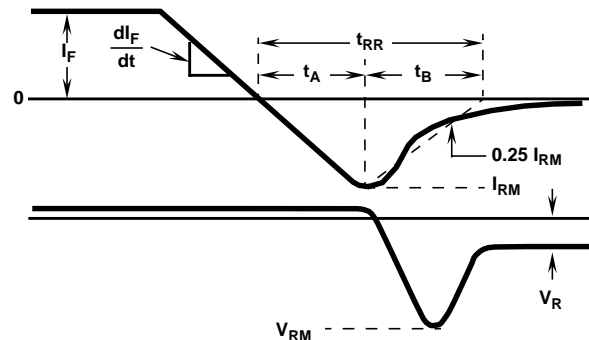

FIGURE 2.  $t_{RR}$  WAVEFORMS AND DEFINITIONS

RURU15070, RURU15080, RURU15090, RURU150100

Typical Performance Curves

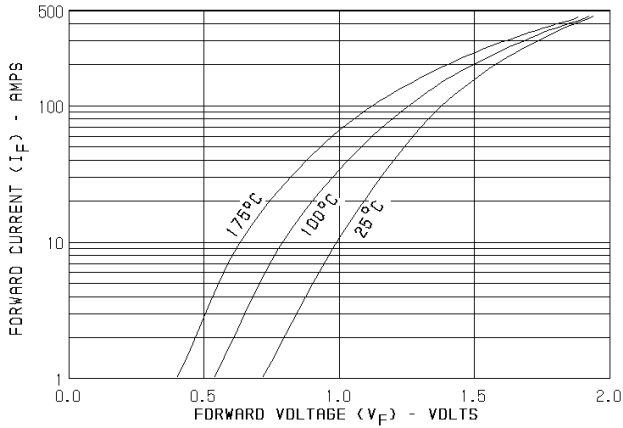

FIGURE 3. TYPICAL FORWARD CURRENT vs FORWARD VOLTAGE DROP

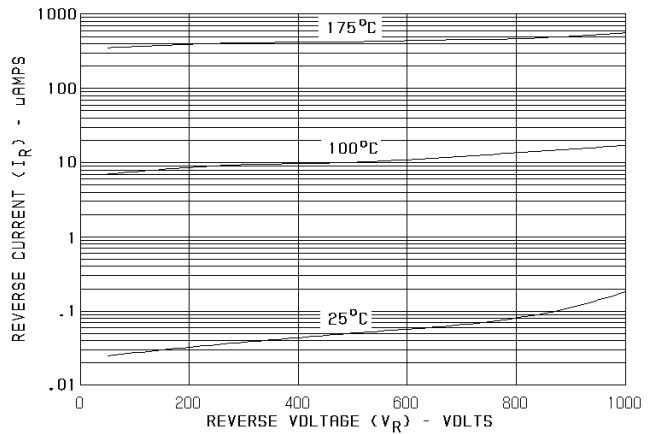

FIGURE 4. TYPICAL REVERSE CURRENT vs VOLTAGE

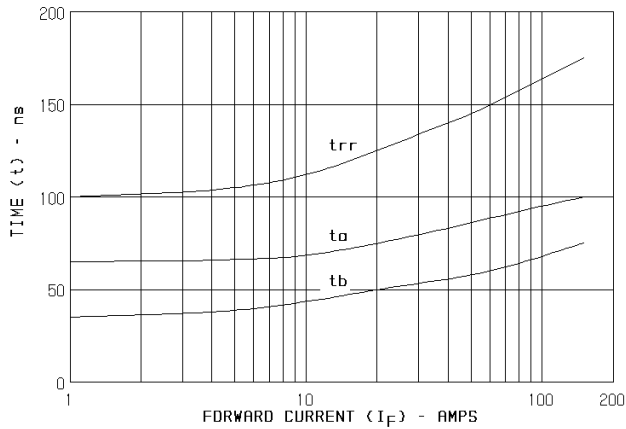

FIGURE 5. TYPICAL  $t_{RR}$ ,  $t_A$  AND  $t_B$  CURVES vs FORWARD CURRENT

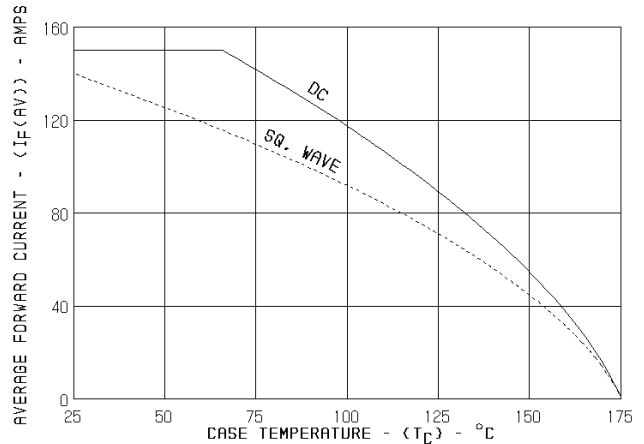

FIGURE 6. CURRENT DERATING CURVE FOR ALL TYPES

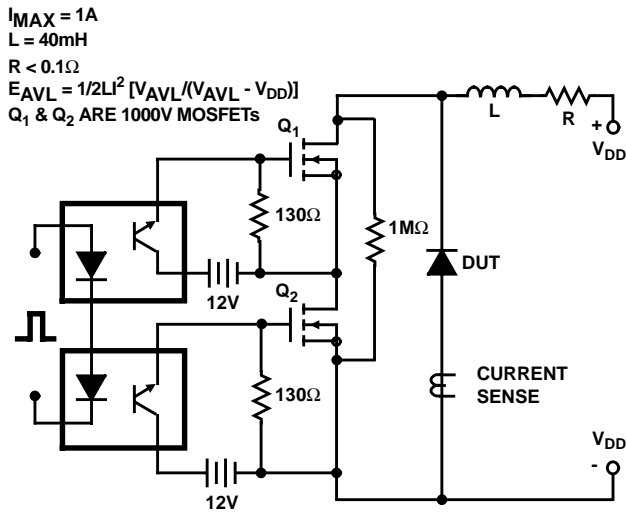

FIGURE 7. AVALANCHE ENERGY TEST CIRCUIT

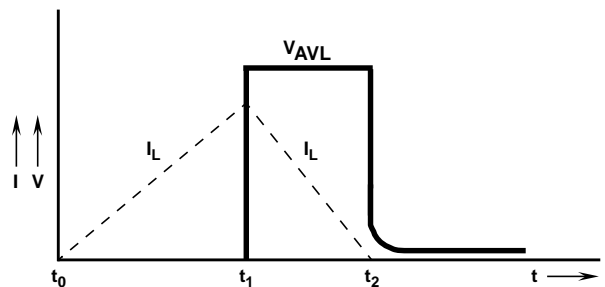

FIGURE 8. AVALANCHE CURRENT AND VOLTAGE WAVEFORMS

**RURU15070, RURU15080, RURU15090, RURU150100**

All Intersil semiconductor products are manufactured, assembled and tested under **ISO9000** quality systems certification.

*Intersil semiconductor products are sold by description only. Intersil Corporation reserves the right to make changes in circuit design and/or specifications at any time without notice. Accordingly, the reader is cautioned to verify that data sheets are current before placing orders. Information furnished by Intersil is believed to be accurate and reliable. However, no responsibility is assumed by Intersil or its subsidiaries for its use; nor for any infringements of patents or other rights of third parties which may result from its use. No license is granted by implication or otherwise under any patent or patent rights of Intersil or its subsidiaries.*

For information regarding Intersil Corporation and its products, see web site **[www.intersil.com](http://www.intersil.com)**

**Sales Office Headquarters**

**NORTH AMERICA**

Intersil Corporation  
P. O. Box 883, Mail Stop 53-204  
Melbourne, FL 32902  
TEL: (321) 724-7000  
FAX: (321) 724-7240

**EUROPE**

Intersil SA  
Mercure Center  
100, Rue de la Fusee  
1130 Brussels, Belgium  
TEL: (32) 2.724.2111  
FAX: (32) 2.724.22.05

**ASIA**

Intersil (Taiwan) Ltd.  
7F-6, No. 101 Fu Hsing North Road  
Taipei, Taiwan  
Republic of China  
TEL: (886) 2 2716 9310  
FAX: (886) 2 2715 3029