

SHINDENGEN

Bridge Diode

Square In-line Package

S15WB20

200V 15A

OUTLINE DIMENSIONS

Case : S15WB

Unit : mm

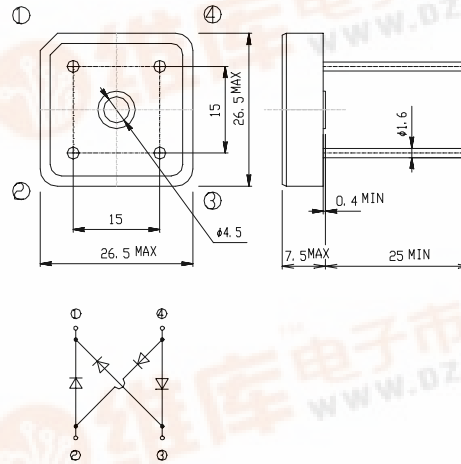

RATINGS

Absolute Maximum Ratings

Item	Symbol	Conditions	Ratings	Unit
Storage Temperature	Tstg		-40~150	°C
Operating Junction Temperature	Tj		150	°C
Maximum Reverse Voltage	V _{RM}		200	V
Average Rectified Forward Current	I _O	50Hz sine wave, R-load With heatsink Tc=77°C	15	A
		50Hz sine wave, R-load Without heatsink Ta=25°C	4	
Peak Surge Forward Current	I _{FSM}	50Hz sine wave, Non-repetitive 1cycle peak value, Tj=25°C	200	A
Current Squared Time	I ² t	1ms ≤ t < 10ms Tc=25°C	200	A ² s
Dielectric Strength	Vdis	Terminals to case, AC 1 minute	2	kV
Mounting Torque	TOR	(Recommended torque : 1N·m)	2	N·m

Electrical Characteristics (If not specified Tc=25°C)

Item	Symbol	Conditions	Ratings	Unit
Forward Voltage	V _F	I _F =7.5A, Pulse measurement, Rating of per diode	Max.1.05	V
Reverse Current	I _R	V _R =V _{RM} , Pulse measurement, Rating of per diode	Max.10	μA
Thermal Resistance	θ _{jc}	junction to case	Max.2.5	°C/W
	θ _{jl}	junction to lead	Max.2	
	θ _{ja}	junction to ambient	Max.19	



S15WBx

Forward Voltage

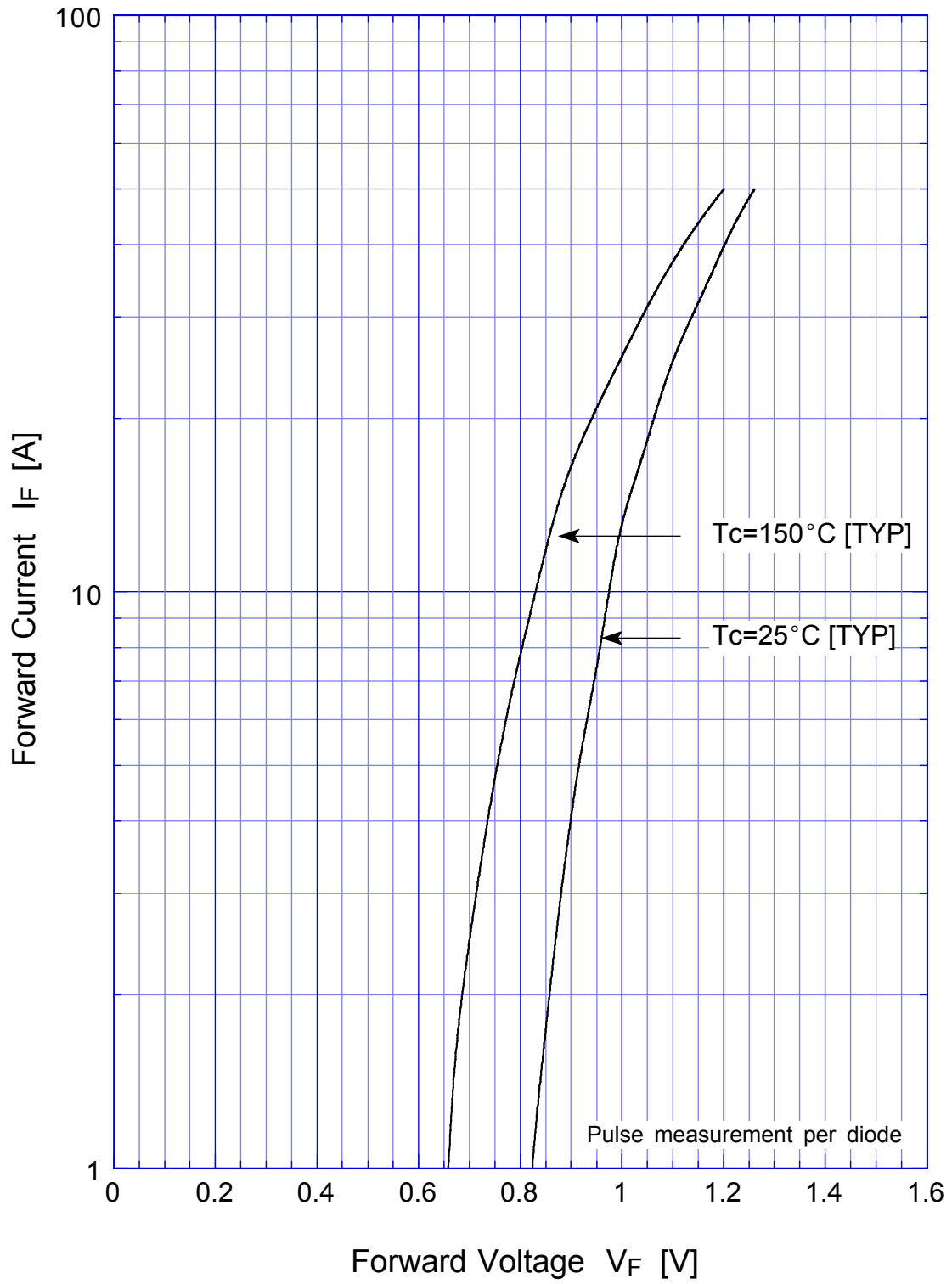

S15WBx Forward Power Dissipation

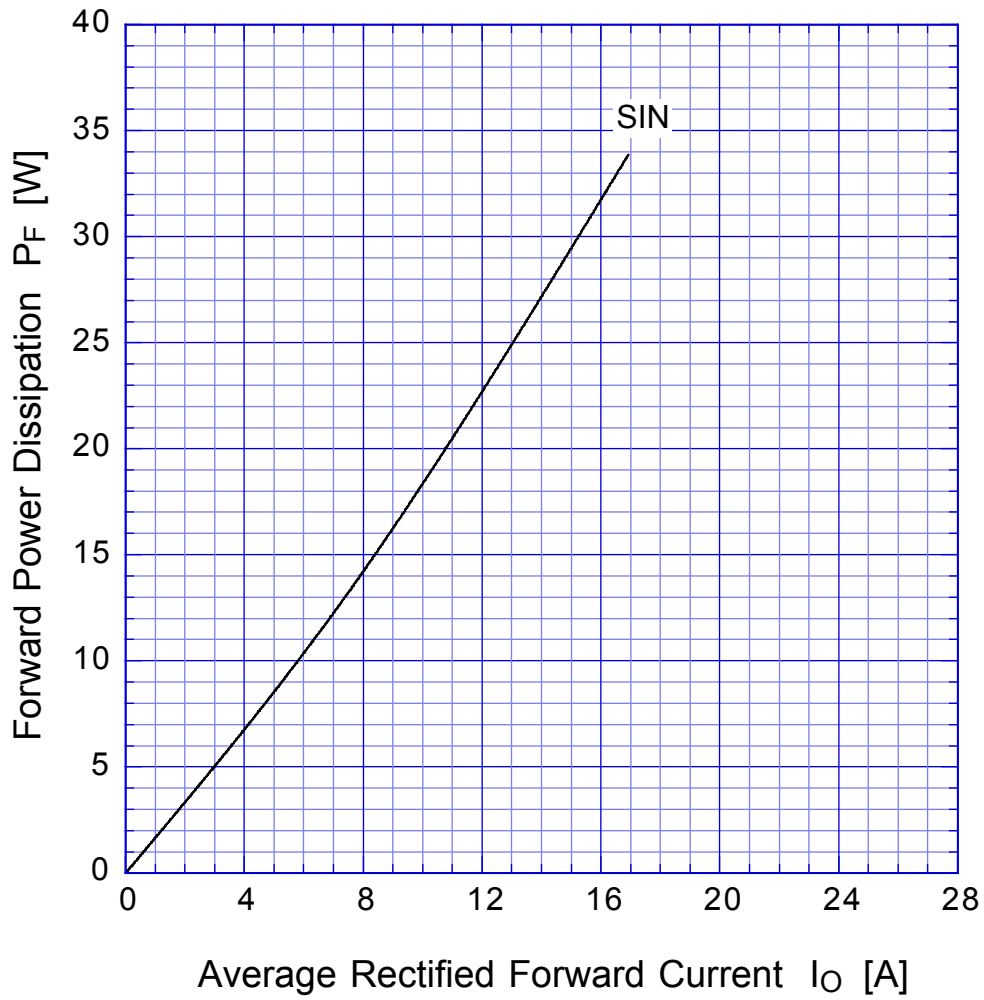

$T_j = 150^\circ\text{C}$
Sine wave

S15WBx

Derating Curve

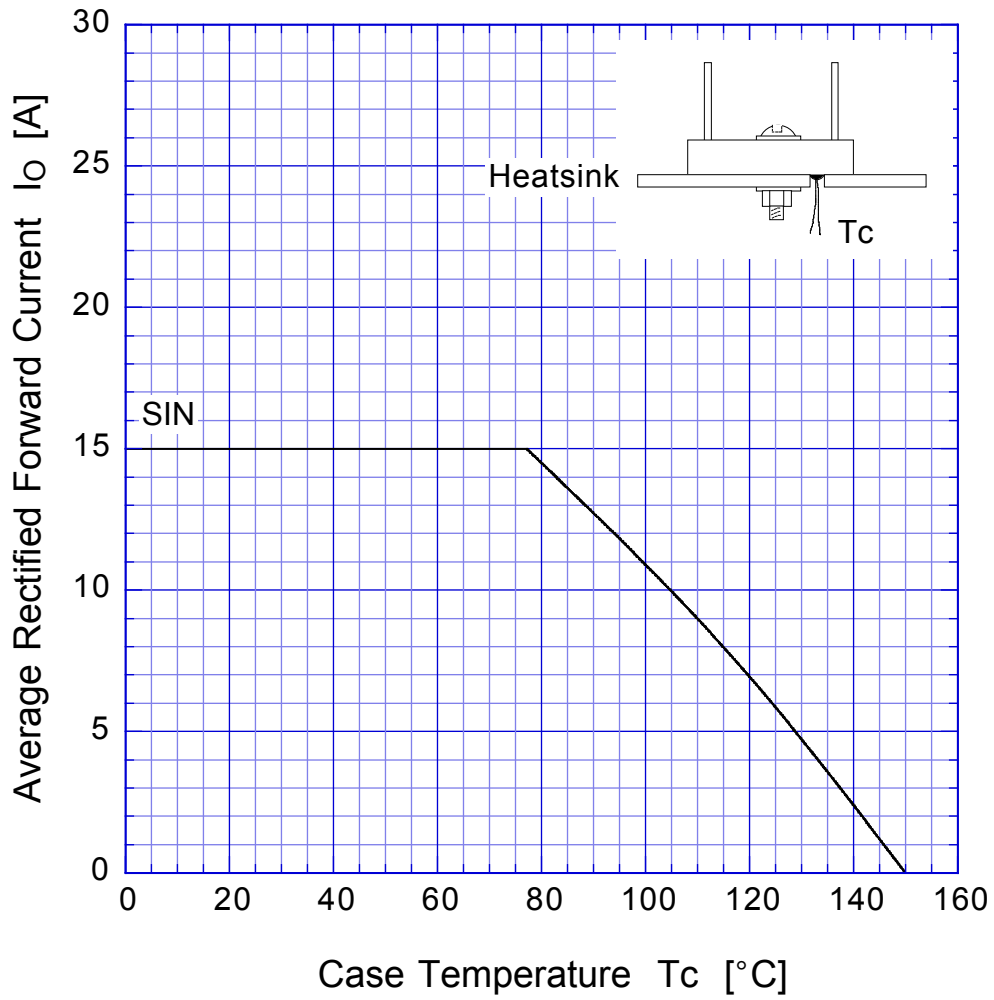

Sine wave
R-load
with heatsink

S15WBx

Derating Curve

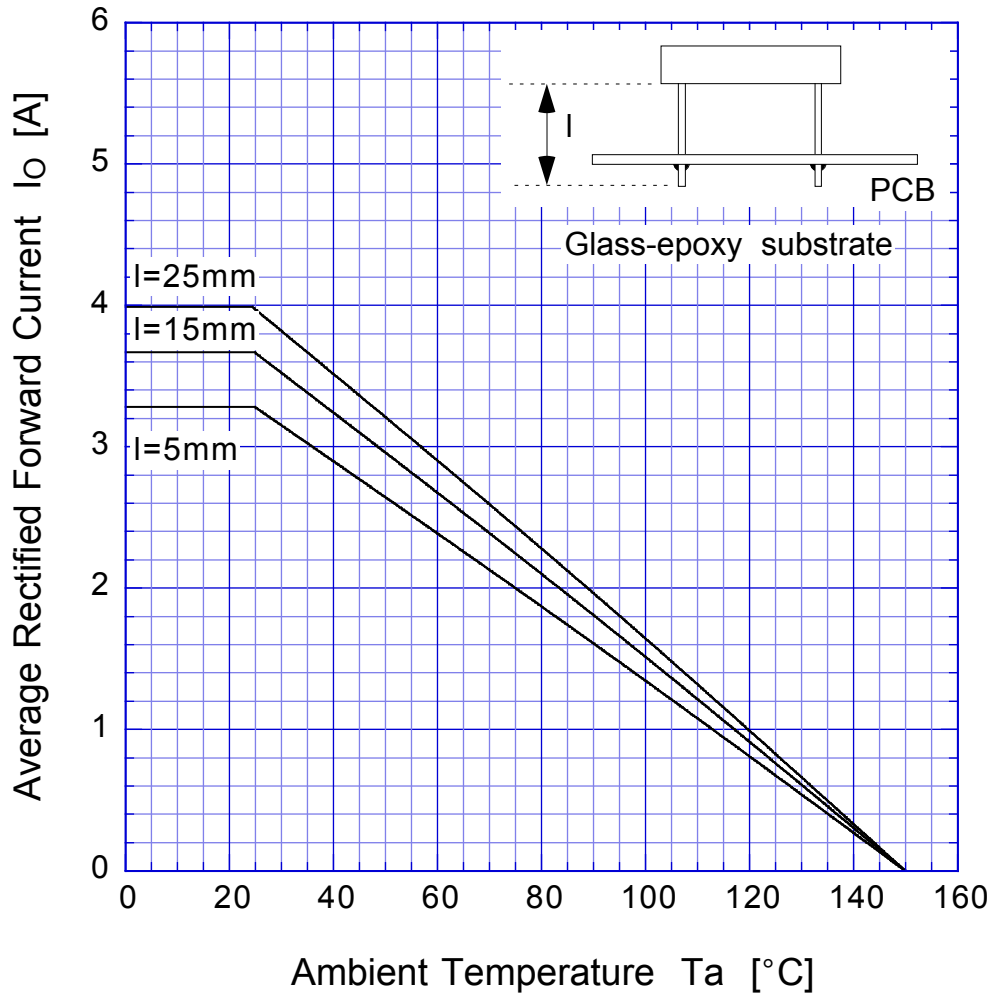

Sine wave
R-load
Free in air

S15WBx

Peak Surge Forward Capability

