

DUAL EQ AMP WITH ALC

S1A0241A01

INTRODUCTION

The S1A0241A01 is a monolithic integrated circuit consisting of a dual equalizer amplifier with ALC, and it is suitable for stereo radio cassette-tape recorders.

FEATURES

- Dual equalizer amplifier with built-in ALC circuit Low noise;  $V_{NI} = 1.0\mu V$  (Typ)
- High open loop voltage gain: 80dB (Typ)
- Wide operating supply voltage range:  $V_{CC} = 4.5V - 14V$
- Good ALC response balance between channels
- Input coupling capacitor unnecessary
- Diode or transistor for ALC unnecessary
- Minimum number of external parts required

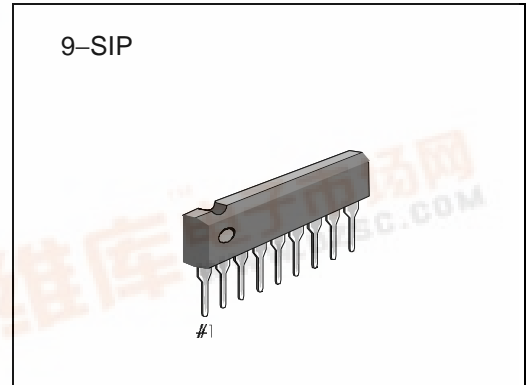

ORDERING INFORMATION]

Device	Package	Operating Temperature
S1A0241A01-I0B0	9-SIP	-20°C — +75C

BLOCK DIAGRAM

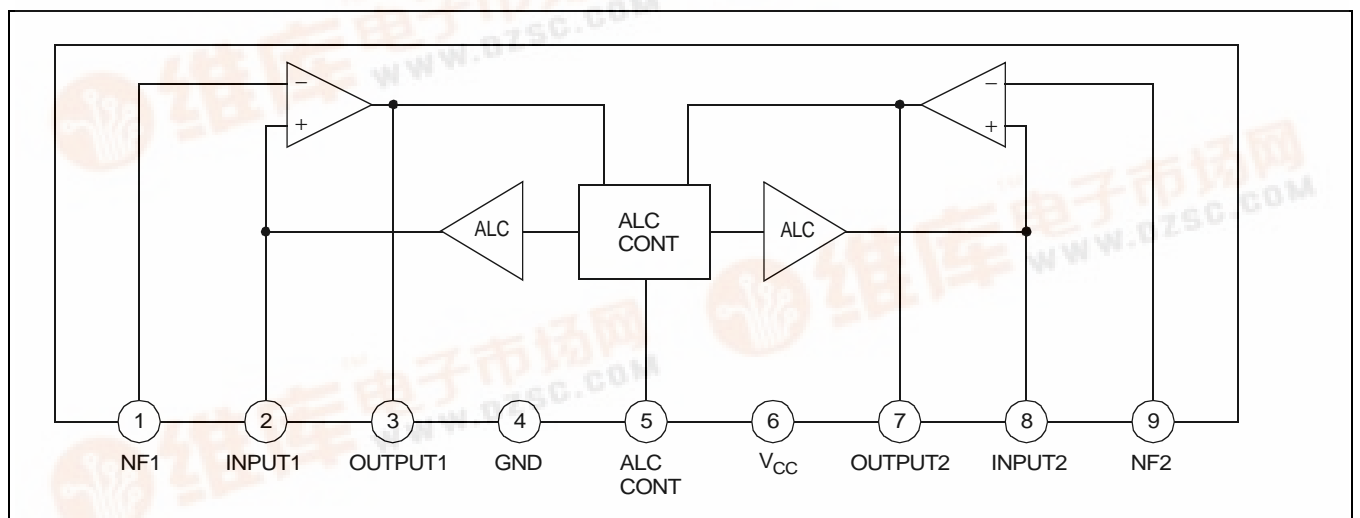

**ABSOLUTE MAXIMUM RATINGS (Ta = 25°C)**

Characteristic	Symbol	Value	Unit
Supply Voltage	$V_{CC}$	16	V
Power Dissipation	$P_D$	(NOTE) 550	mW
Operating Temperature	$T_{OPR}$	-20 — +75	°C
Storage Temperature	$T_{STG}$	-20 — +125	°C

**NOTE:** Derated above Ta = 25 °C in the propotion of 5.5 mW/°C

**ELECTRICAL CHARACTERISTICS**

(Ta = 25°C,  $V_{CC}$  = 7V, f = 1kHz, unless otherwise specified)

Characteristic	Symbol	Test Conditions	Min.	Typ.	Max.	Unit
Quiescent Circuit Current	$I_{CCQ}$	$V_I = 0$	1.5	3.5	4.5	mA
Open Loop Voltage Gain	$G_{VO}$	$V_O = 0.3V$	70	80	–	dB
Closed Loop Voltage Gain	$G_{VC}$	$V_O = 0.3V$	45	48	50	dB
Output Voltage	$V_O$	THD = 1%	0.6	1.2	–	V
Total Harmonic Distortion	THD	$V_O = 0.3V$	–	0.1	0.3	%
Equivalent Input Noise Voltage	$V_{NI}$	$R_G = 2.2k\Omega$ , BW (-3dB)=20Hz – 20kHz	–	1.0	2.0	$\mu V$
Input Resistance	$R_I$	–	15	25	45	k $\Omega$
ALC Range	$\Delta V_{ALC}$	$R_G = 3.9k\Omega$ , THD = 10%	40	45	–	dB
ALC Balance	$CB_{ALC}$	$V_I = 1mV$	–	0	2.5	dB

TEST CIRCUIT

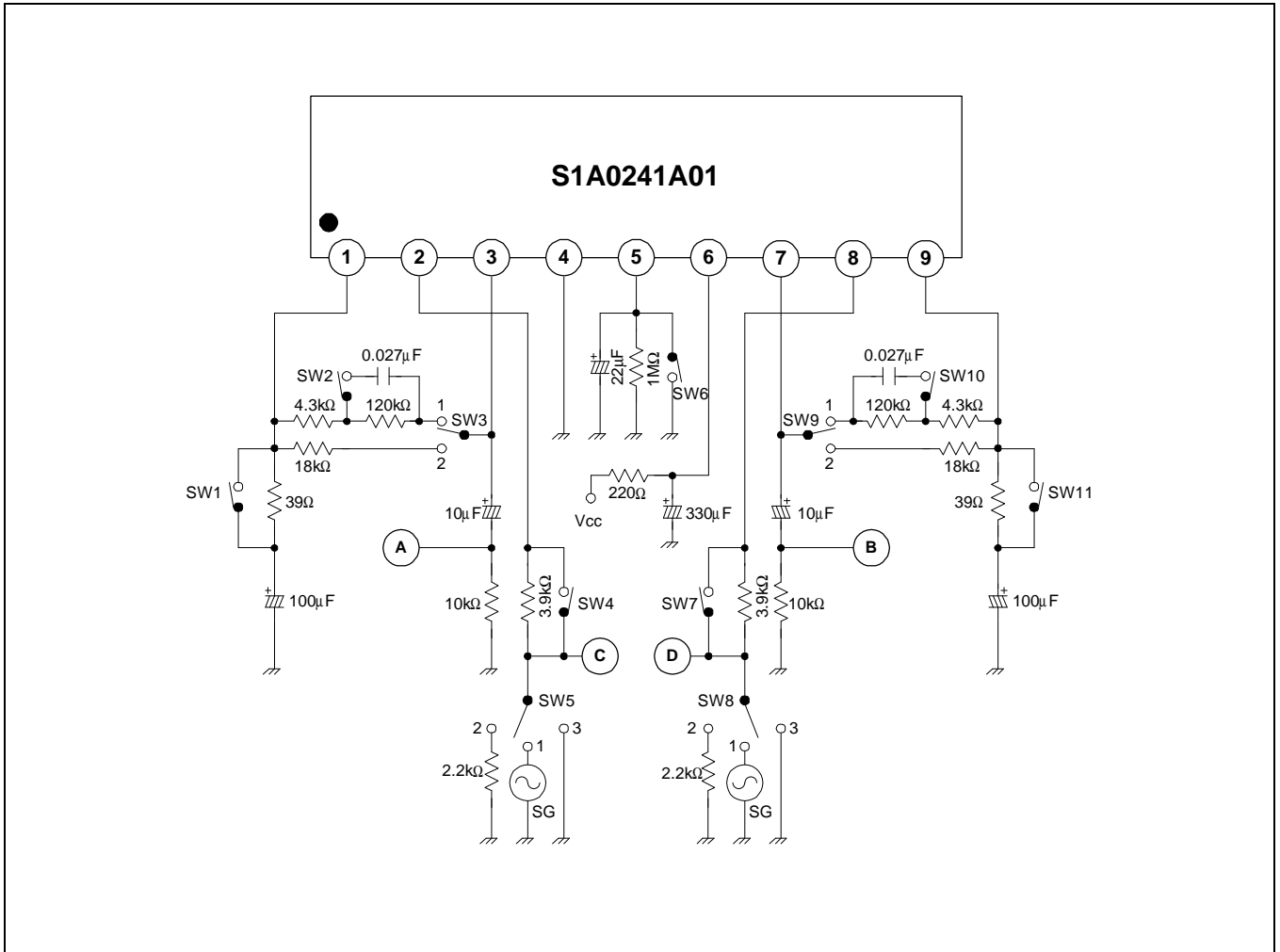

## TEST METHOD

Symbol		S1	S2	S3	S4	S5	S6	S7	S8	S9	S10	S11
$I_{CCQ}$		ON	OFF	1	ON	3	ON	ON	3	1	OFF	ON
$G_{VO}$		ON	OFF	1	ON	1	ON	ON	3	1	OFF	ON
$G_{VC}$	CH -1	OFF	ON	1	ON	1	ON	ON	3	1	OFF	ON
THD	CH -1	OFF	ON	1	ON	1	ON	ON	3	1	OFF	ON
$V_O$	CH -1	OFF	ON	1	ON	1	ON	ON	3	1	OFF	ON
$V_{NI}$	CH -1	OFF	ON	1	ON	2	ON	ON	3	1	OFF	ON
	CH -2	ON	OFF	1	ON	3	ON	ON	2	1	ON	OFF
$\Delta V_{ALC}$	CH -1	OFF	OFF	2	OFF	1	OFF	ON	3	1	OFF	ON
$CB_{ALC}$		OFF	OFF	2	OFF	1	OFF	OFF	1	2	OFF	OFF

APPLICATION CIRCUIT

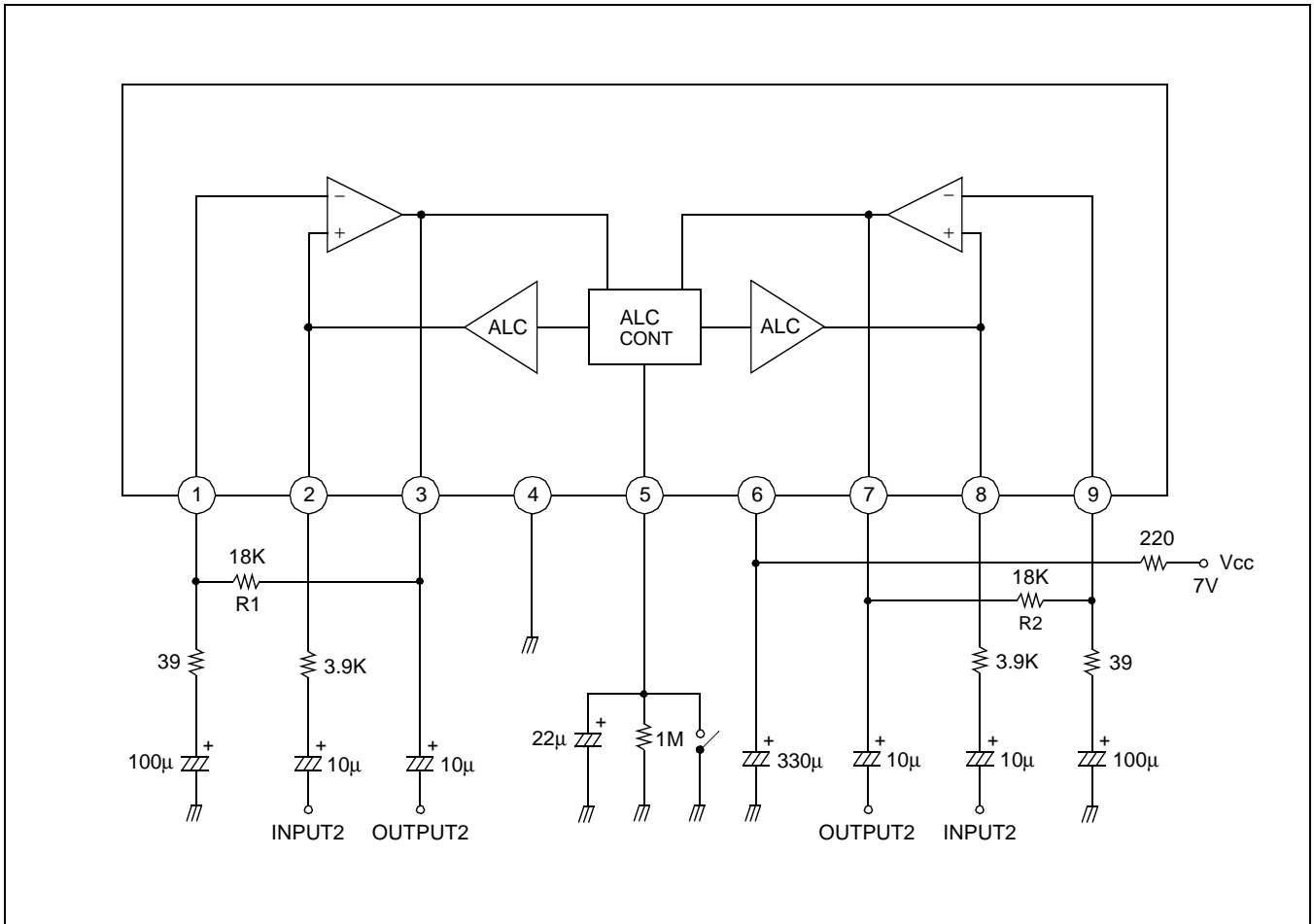

**NOTE:** ON playback, connect the time constant circuit as shown below, instead of R1 of Pins 1, 3 and R2 of Pins 7, 9, which are used in the NAB.

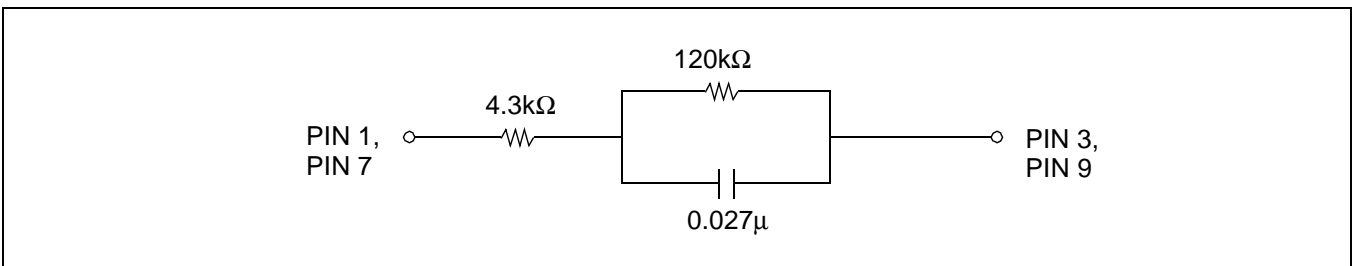

APPLICATION CIRCUIT 1

