

# S21MT1/S21MT2

## Compact 4-pin DIP Type Phototriac Coupler

### ■ Features

1. Compact 4-pin DIP type  
(Package area : 2/3 of conventional model)
2. Popular type
3. Recognized by UL (No. E64380)

### ■ Model Line-ups

	For 200V line
Zero-cross circuit not built in	<b>S21MT1</b>
Zero-cross circuit built in	<b>S21MT2</b>

### ■ Application

1. For SSR

### ■ Outline Dimensions

(Unit : mm)

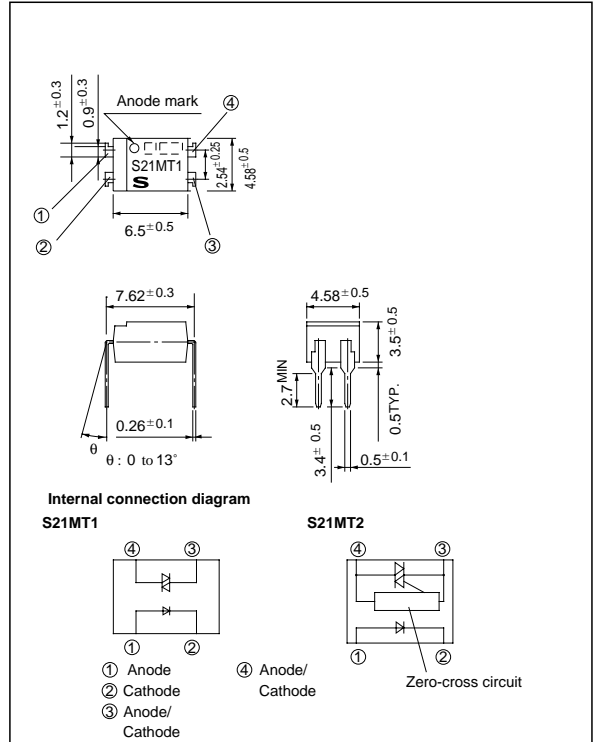

### ■ Absolute Maximum Ratings

(Ta=25°C)

Parameter		Symbol	Rating	Unit
Input	Forward current	I <sub>F</sub>	50	mA
	Reverse voltage	V <sub>R</sub>	6	V
Output	*1 RMS ON-state current	I <sub>T</sub>	0.1	A <sub>rms</sub>
	Peak one cycle surge current	I <sub>surge</sub>	1.2 (50Hz sine wave)	A
	Repetitive peak OFF-state voltage	V <sub>DRM</sub>	600	V
*2 Isolation voltage		V <sub>iso</sub>	5 000	V <sub>rms</sub>
Operating temperature		T <sub>opr</sub>	-30 to +100	°C
Storage temperature		T <sub>stg</sub>	-55 to +125	°C
*3 Soldering temperature		T <sub>sol</sub>	260 (for 10 sec)	°C

\*1 Decrease in the ambient temperature range of the Absolute Max. Rating : Shown in Figs. 1 and 2.

\*2 40 to 60% RH, AC for 1 minute

\*3 For 10 seconds

■ Electro-optical Characteristics

(Ta=25°C)

Parameter		Symbol	Conditions	MIN.	TYP.	MAX.	Unit
Input	Forward voltage	$V_F$	$I_F = 20\text{mA}$	-	1.2	1.4	V
	Reverse current	$I_R$	$V_R = 3\text{V}$	-	-	10	$\mu\text{A}$
Output	Repetitive peak OFF-state current	$I_{DRM}$	$V_{DRM} = \text{Rated}$	-	-	1	$\mu\text{A}$
	ON-state voltage	$V_T$	$I_T = 0.05\text{A}$	-	-	3.0	V
	Holding current	$I_H$	$V_D = 6\text{V}$	0.1	-	3.5	mA
	Critical rate of rise of OFF-state voltage	$dv/dt$	$V_{DRM} = (1/\sqrt{2}) \cdot \text{Rated}$	100	-	-	$\text{V}/\mu\text{s}$
	Zero-cross voltage	<b>S21MT2</b> $V_{OX}$	$I_F = 15\text{mA}$ , Resistance load	-	-	35	V
Transfer characteristics	Minimum trigger current	$I_{FT}$	$R_L = 100\Omega$ , $V_D = 6\text{V}$	-	-	10	mA
	Insulation resistance	$R_{ISO}$	$DC = 500\text{V}$ , 40 to 60% RH	$5 \times 10^{10}$	$1 \times 10^{11}$	-	$\Omega$
	Turn-on time	<b>S21MT1</b>	$t_{on}$	$V_D = 6\text{V}$ , $R_L = 100\Omega$ , $I_F = 20\text{mA}$	-	-	100
<b>S21MT2</b>		-			-	50	

Fig. 1 RMS ON-state Current vs. Ambient Temperature

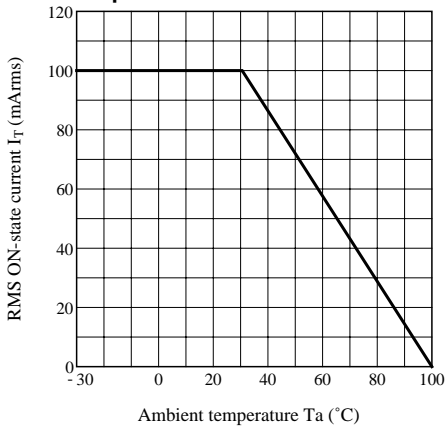
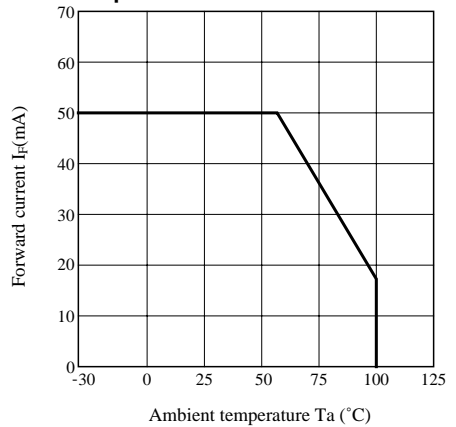

Fig. 2 Forward Current vs. Ambient Temperature



● Please refer to the chapter "Precautions for Use." (Page 78 to 93)