

DATA SHEET

SA636

Low voltage high performance mixer FM
IF system with high-speed RSSI

Product specification

Replaces data of 1994 Jun 16

IC17 Data Handbook

1997 Nov 07

Philips Semiconductors

PHILIPS



Low voltage high performance mixer FM IF system with high-speed RSSI

SA636

DESCRIPTION

The SA636 is a low-voltage high performance monolithic FM IF system with high-speed RSSI incorporating a mixer/oscillator, two limiting intermediate frequency amplifiers, quadrature detector, logarithmic received signal strength indicator (RSSI), voltage regulator, wideband data output and fast RSSI op amps. The SA636 is available in 20-lead SSOP (shrink small outline package).

The SA636 was designed for high bandwidth portable communication applications and will function down to 2.7V. The RF section is similar to the famous SA605. The data output has a minimum bandwidth of 600kHz. This is designed to demodulate wideband data. The RSSI output is amplified. The RSSI output has access to the feedback pin. This enables the designer to adjust the level of the outputs or add filtering.

SA636 incorporates a power down mode which powers down the device when Pin 8 is low. Power down logic levels are CMOS and TTL compatible with high input impedance.

APPLICATIONS

- DECT (Digital European Cordless Telephone)
- Digital cordless telephones
- Digital cellular telephones
- Portable high performance communications receivers
- Single conversion VHF/UHF receivers
- FSK and ASK data receivers
- Wireless LANs

FEATURES

- Wideband data output (600kHz min.)
- Fast RSSI rise and fall times
- Low power consumption: 6.5mA typ at 3V
- Mixer input to >500MHz
- Mixer conversion power gain of 11dB at 240MHz
- Mixer noise figure of 12dB at 240MHz

PIN CONFIGURATION

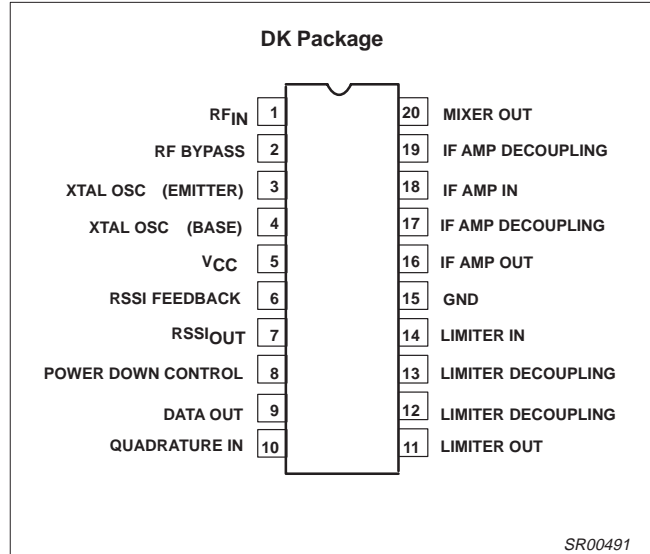

Figure 1. Pin Configuration

- XTAL oscillator effective to 150MHz (L.C. oscillator to 1GHz local oscillator can be injected)
- 92dB of IF Amp/Limiter gain
- 25MHz limiter small signal bandwidth
- Temperature compensated logarithmic Received Signal Strength Indicator (RSSI) with a dynamic range in excess of 90dB
- RSSI output internal op amp
- Internal op amps with rail-to-rail outputs
- Low external component count; suitable for crystal/ceramic/LC filters
- Excellent sensitivity: 0.54µV into 50Ω matching network for 12dB SINAD (Signal to Noise and Distortion ratio) for 1kHz tone with RF at 240MHz and IF at 10.7MHz
- ESD hardened
- 10.7MHz filter matching (330Ω)
- Power down mode (I_{CC} = 200µA)

ORDERING INFORMATION

| DESCRIPTION | TEMPERATURE RANGE | ORDER CODE | DWG # |
|---|-------------------|------------|----------|
| 20-Pin Plastic Shrink Small Outline Package (Surface-mount) | -40 to +85°C | SA636DK | SOT266-1 |

Low voltage high performance mixer FM IF system with high-speed RSSI

SA636

BLOCK DIAGRAM

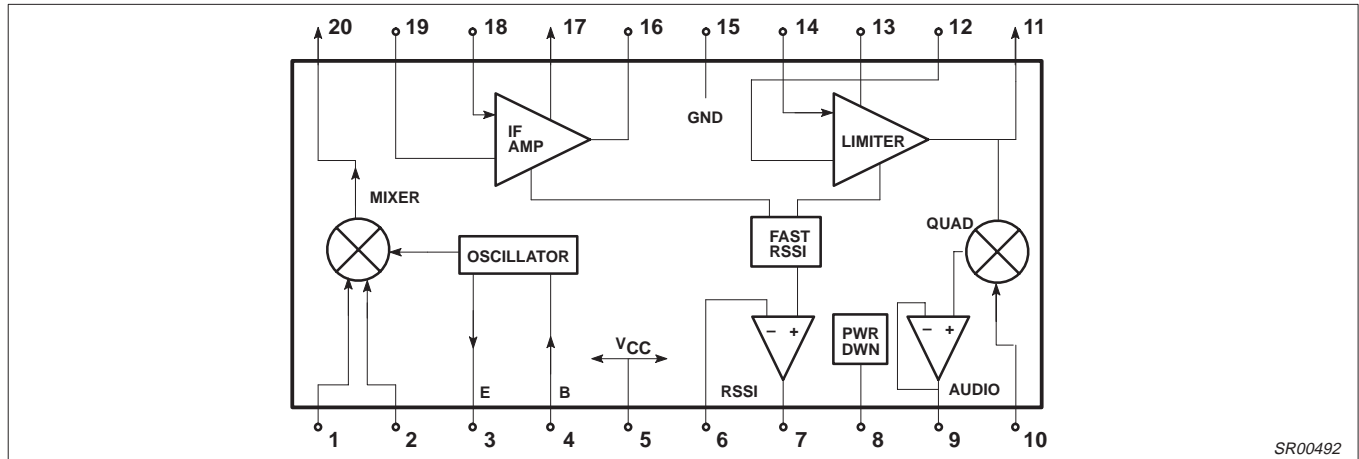

Figure 2. Block Diagram

ABSOLUTE MAXIMUM RATINGS

| SYMBOL | PARAMETER | RATING | UNITS |
|-----------|---|--------------------------|-------|
| V_{CC} | Single supply voltage | 0.3 to 7 | V |
| V_{IN} | Voltage applied to any other pin | -0.3 to ($V_{CC}+0.3$) | V |
| T_{STG} | Storage temperature range | -65 to +150 | °C |
| T_A | Operating ambient temperature range SA636 | -40 to +85 | °C |

NOTE: θ_{JA} , Thermal impedance DK package 117°C/W

DC ELECTRICAL CHARACTERISTICS

$V_{CC} = +3V$, $T_A = 25^\circ C$; unless otherwise stated.

| SYMBOL | PARAMETER | TEST CONDITIONS | LIMITS | | | UNITS |
|-----------|----------------------------|---------------------------|-------------|-----|-------------|---------|
| | | | SA636 | | | |
| | | | MIN | TYP | MAX | |
| V_{CC} | Power supply voltage range | | 2.7 | 3.0 | 5.5 | V |
| I_{CC} | DC current drain | Pin 8 = HIGH | 5.5 | 6.5 | 7.5 | mA |
| | Input current | Pin 8 LOW | -10 | | 10 | μA |
| | | Pin 8 HIGH | -10 | | 10 | |
| | Input level | Pin 8 LOW | 0 | | $0.3V_{CC}$ | V |
| | | Pin 8 HIGH | $0.7V_{CC}$ | | V_{CC} | |
| I_{CC} | Standby | Pin 8 = LOW | | 0.2 | 0.5 | mA |
| t_{ON} | Power up time | RSSI valid (10% to 90%) | | 10 | | μs |
| t_{OFF} | Power down time | RSSI invalid (90% to 10%) | | 5 | | μs |

Low voltage high performance mixer FM IF system with high-speed RSSI

SA636

AC ELECTRICAL CHARACTERISTICS

$T_A = 25^\circ\text{C}$; $V_{CC} = +3\text{V}$, unless otherwise stated. RF frequency = 240.05MHz + 14.5dBV RF input step-up; IF frequency = 10.7MHz; RF level = -45dBm; FM modulation = 1kHz with $\pm 125\text{kHz}$ peak deviation. Audio output with C-message weighted filter and de-emphasis capacitor. Test circuit Figure 1. The parameters listed below are tested using automatic test equipment to assure consistent electrical characteristics. The limits do not represent the ultimate performance limits of the device. Use of an optimized RF layout will improve many of the listed parameters.

| SYMBOL | PARAMETER | TEST CONDITIONS | LIMITS | | | UNITS |
|---|--|--|--------|-----------|-----|-------------------|
| | | | SA636 | | | |
| | | | MIN | TYP | MAX | |
| Mixer/Osc section (ext LO = 160mV_{RMS}) | | | | | | |
| f_{IN} | Input signal frequency | | | 500 | | MHz |
| f_{OSC} | External oscillator (buffer) | | | 500 | | MHz |
| | Noise figure at 240MHz | | | 12 | | dB |
| | Third-order input intercept point | Matched $f_1=240.05$; $f_2=240.35\text{MHz}$ | | -16 | | dBm |
| | Conversion power gain | Matched 14.5dBV step-up | 8 | 11 | 14 | dB |
| | RF input resistance | Single-ended input | | 700 | | Ω |
| | RF input capacitance | | | 3.5 | | pF |
| | Mixer output resistance | (Pin 20) | | 330 | | Ω |
| IF section | | | | | | |
| | IF amp gain | 330 Ω load | | 38 | | dB |
| | Limiter gain | 330 Ω load | | 54 | | dB |
| | Input limiting -3dB | Test at Pin 18 | | -105 | | dBm |
| | AM rejection | 80% AM 1kHz | | 50 | | dB |
| | Data level | $R_{LOAD} = 100\text{k}\Omega$ | 120 | 130 | | mV _{RMS} |
| | 3dB data bandwidth | | 600 | 700 | | kHz |
| | SINAD sensitivity | RF level = -111dBm | | 16 | | dB |
| THD | Total harmonic distortion | | | -43 | -38 | dB |
| S/N | Signal-to-noise ratio | No modulation for noise | | 60 | | dB |
| | IF RSSI output with buffer | IF level = -118dBm | | 0.2 | 0.5 | V |
| | | IF level = -68dBm | 0.3 | 0.6 | 1.0 | V |
| | | IF level = -10dBm | 0.9 | 1.3 | 1.8 | V |
| | IF RSSI output rise time (10kHz pulse, no 10.7MHz filter) (no RSSI bypass capacitor) | IF frequency = 10.7MHz RF level = -56dBm RF level = -28dBm | | 1.2 | | μs |
| | | | | | 1.1 | |
| | IF RSSI output fall time (10kHz pulse, no 10.7MHz filter) (no RSSI bypass capacitor) | IF frequency = 10.7MHz RF level = -56dBm RF level = -28dBm | | 2.0 | | μs |
| | | | | | 7.3 | |
| | RSSI range | | | 90 | | dB |
| | RSSI accuracy | | | ± 1.5 | | dB |
| | IF input impedance | | | 330 | | Ω |
| | IF output impedance | | | 330 | | Ω |
| | Limiter input impedance | | | 330 | | Ω |
| | Limiter output impedance | | | 300 | | Ω |
| | Limiter output level with no load | | | 130 | | mV _{RMS} |
| RF/IF section (int LO) | | | | | | |
| | System RSSI output | RF level = -10dBm | | 1.4 | | V |
| | System SINAD | RF level = -106dBm | | 12 | | dB |

Low voltage high performance mixer FM IF system with high-speed RSSI

SA636

PERFORMANCE CHARACTERISTICS

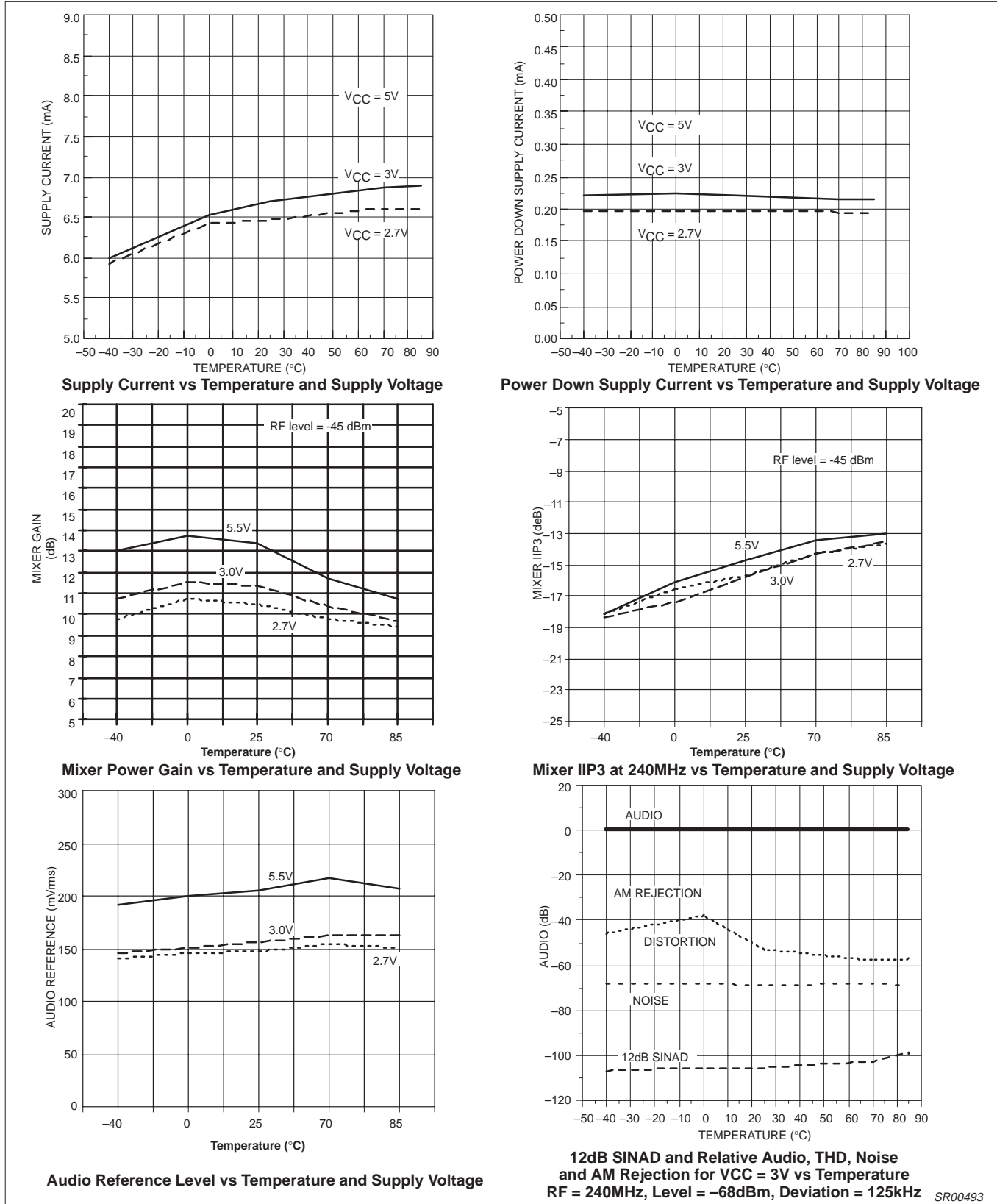

Figure 3. Performance Characteristics

Low voltage high performance mixer FM IF system with high-speed RSSI

SA636

PERFORMANCE CHARACTERISTICS (continued)

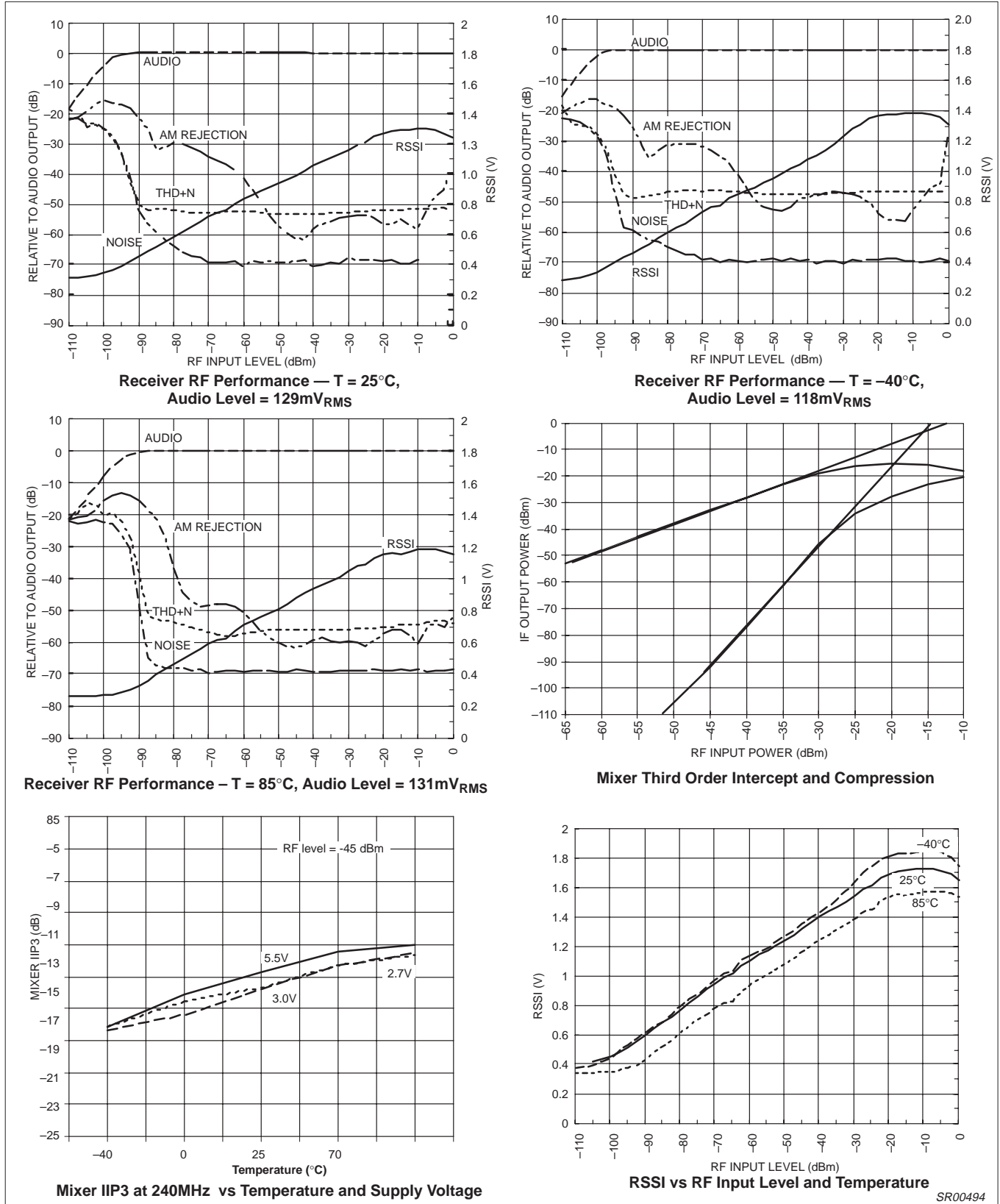
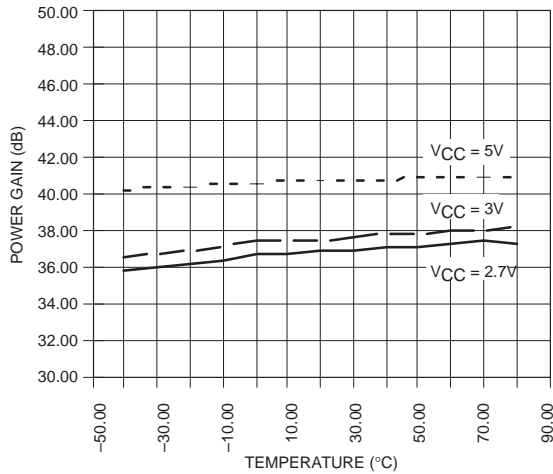

Figure 4. Performance Characteristics

Low voltage high performance mixer FM IF system with high-speed RSSI

SA636

PERFORMANCE CHARACTERISTICS (continued)



SA626 IF Amplifier Gain vs Temperature vs Supply Voltage

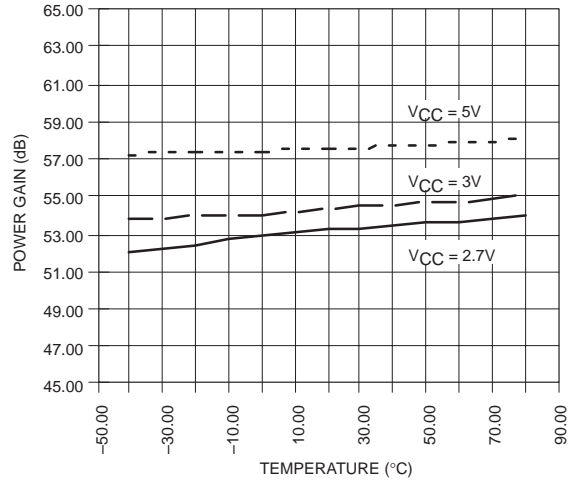

SA626 Limiting Amplifier Gain vs Temperature vs Supply Voltage

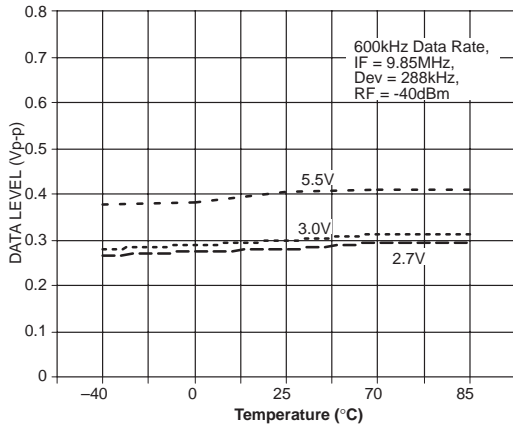

Data Level vs Temperature and Supply Voltage

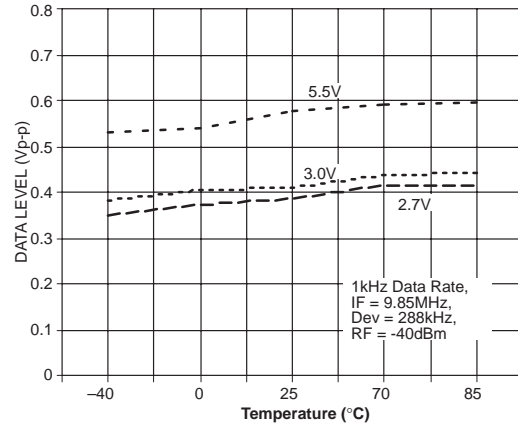

Data Level vs Temperature and Supply Voltage

SR00495

Figure 5. Performance Characteristics

Low voltage high performance mixer FM IF system with high-speed RSSI

SA636

PERFORMANCE CHARACTERISTICS (continued)

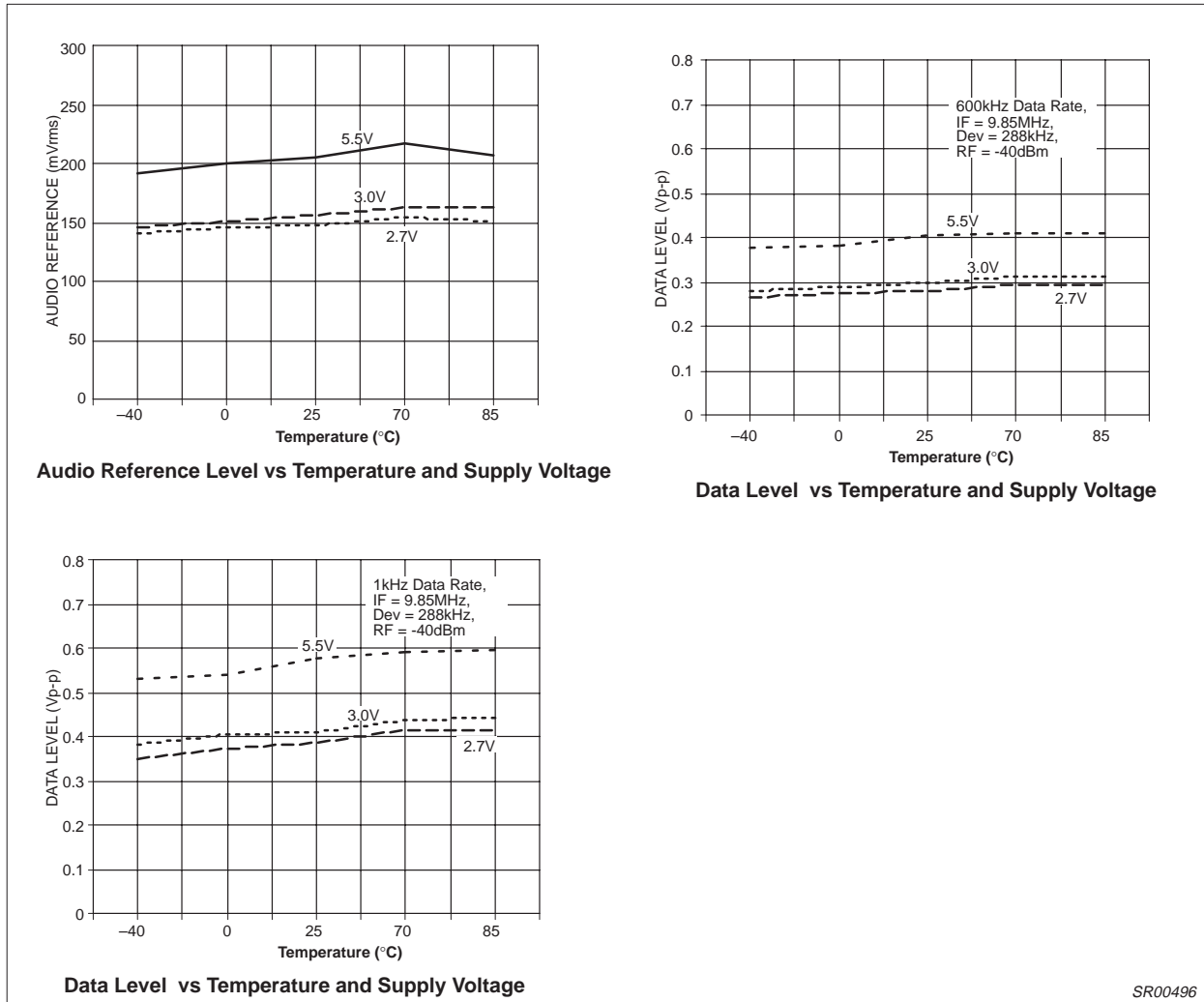

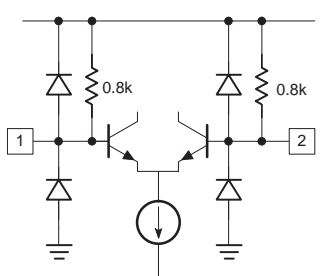
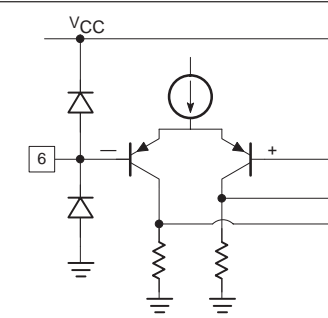

Figure 6. Performance Characteristics

SR00496

Low voltage high performance mixer FM IF system with high-speed RSSI

SA636

PIN FUNCTIONS

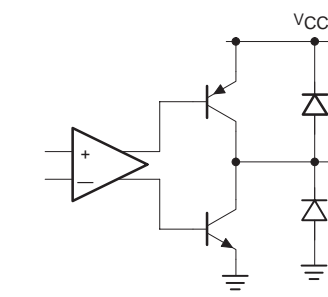
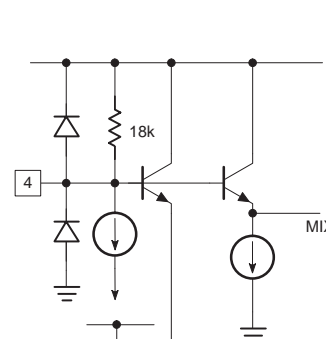
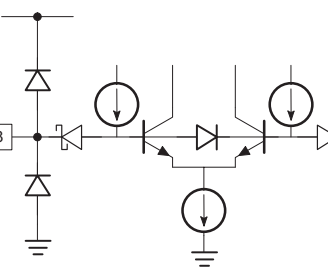
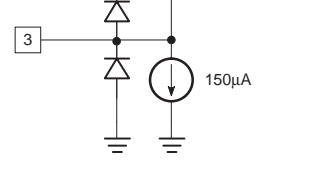
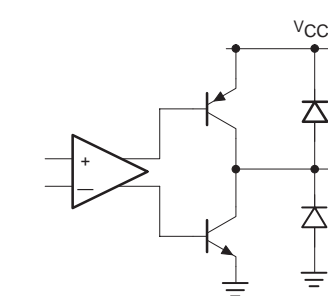
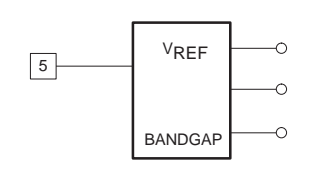
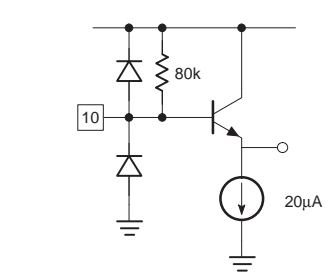
| PIN No. | PIN MNEMONIC | DC V | EQUIVALENT CIRCUIT | PIN No. | PIN MNEMONIC | DC V | EQUIVALENT CIRCUIT |
|---------|-----------------|-------|---|---------|---------------|-------|---|
| 1 | RF IN | +1.07 |  | 6 | RSSI FEEDBACK | +0.20 |  |
| 2 | RF BYPASS | +1.07 |  | 7 | RSSI OUT | +0.20 |  |
| 3 | XTAL OSC | +1.57 |  | 8 | POWER DOWN | +2.75 |  |
| 4 | XTAL OSC | +2.32 |  | 9 | DATA OUT | +1.09 |  |
| 5 | V _{CC} | +3.00 |  | 10 | QUAD. IN | +3.00 |  |

SR00497

Figure 7. Pin Functions

Low voltage high performance mixer FM IF system with high-speed RSSI

SA636

PIN FUNCTIONS (continued)

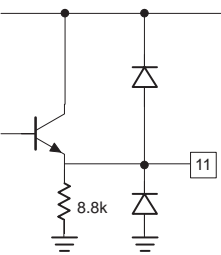
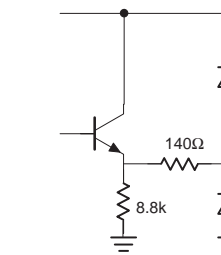
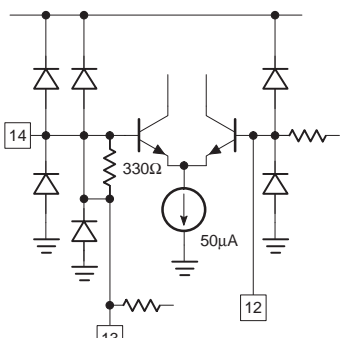
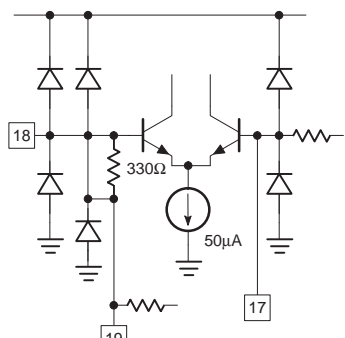
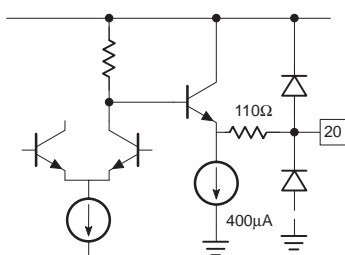
| PIN No. | PIN MNEMONIC | DC V | EQUIVALENT CIRCUIT | PIN No. | PIN MNEMONIC | DC V | EQUIVALENT CIRCUIT |
|---------|------------------|-------|---|---------------|---------------|---|---|
| 11 | LIMITER OUT | +1.35 |  | 16 | IF AMP OUT | +1.22 |  |
| 12 | LIMITER DECOUP | +1.23 |  | 17 | IF AMP DECOUP | +1.22 |  |
| 13 | LIMITER COUPLING | +1.23 | | 18 | IF AMP IN | +1.22 | |
| 14 | LIMITER IN | +1.23 | 19 | IF AMP DECOUP | +1.22 | | |
| 15 | GND | 0 | 20 | MIXER OUT | +1.03 |  | |

SR00498

Figure 8. Pin Functions (cont.)

Low voltage high performance mixer FM IF system with high-speed RSSI

SA636

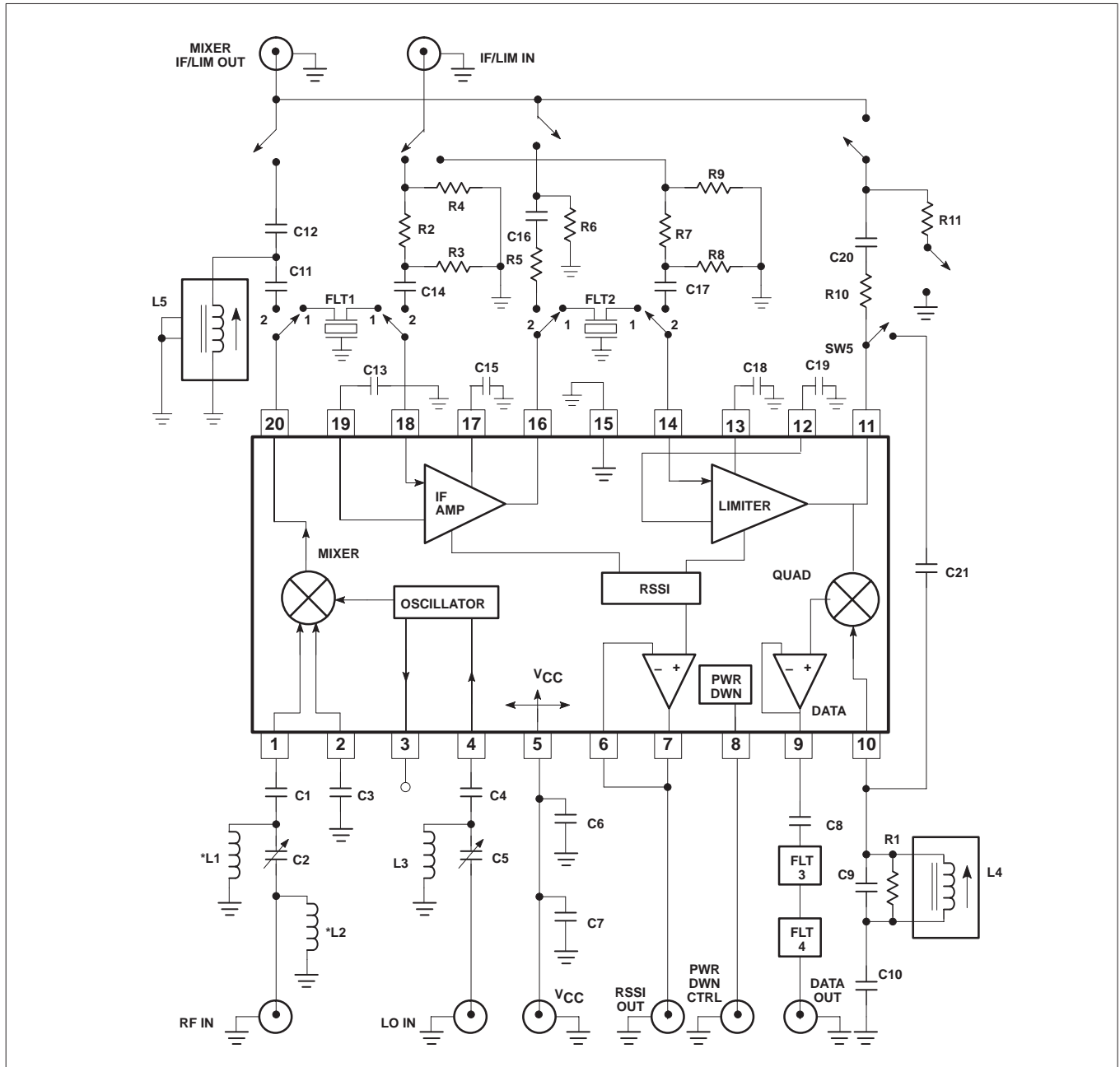

Automatic Test Circuit Component List

| | | | |
|-----------------|---------------------------------|------------------|--|
| R1 8.2kΩ select | C1 0.1μF | C12 160pF select | L1 150nH select for input match |
| R2 6.42kΩ | C2 1–5pF select for input match | C13 1000pF | L2 22nH select for input match |
| R3 347.8Ω | C3 0.1μF | C14 0.1μF | L3 47nH select for input match |
| R4 49.9Ω | C4 0.1μF | C15 1000pF | L4 5.6μH select for input match |
| R5 1kΩ | C5 1–5pF select for input match | C16 0.1μF | L5 1.27–2.25μH select for mixer output match |
| R6 49.9Ω | C6 100pF | C17 0.1μF | |
| R7 6.42kΩ | *C7 6.8μF 10V | C18 1000pF | |
| R8 347.8Ω | C8 1μF | C19 1000pF | FLT1 10.7MHz (Murata SFE10.7MA5-A) |
| R9 49.9Ω | C9 39pF select | C20 0.1μF | FLT2 10.7MHz (Murata SFE10.7MA5-A) |
| R10 1kΩ | C10 0.1μF | C21 1pF | FLT3 "C" message weighted |
| R11 49.9Ω | C11 0.1μF | | FLT4 Active de-emphasis |

*NOTE: This value can be reduced when a battery is the power source.

Figure 9. SA636 240.05MHz (RF) / 10.7MHz (IF) Test Circuit

Low voltage high performance mixer FM IF system with high-speed RSSI

SA636

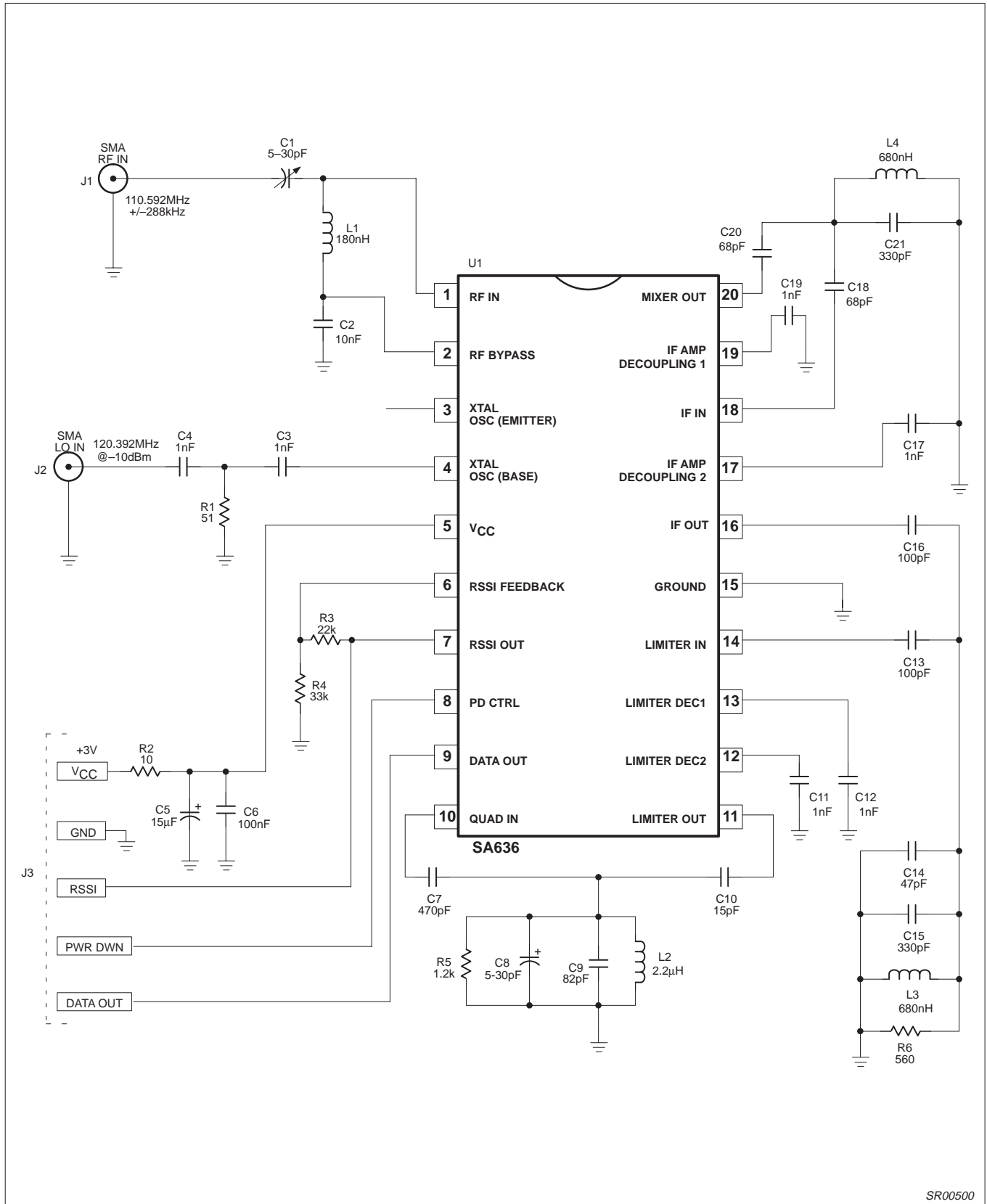

Figure 10. SA636 110.592MHz (RF) / 9.8MHz (IF) DECT Application Circuit

Low voltage high performance mixer FM IF system with high-speed RSSI

SA636

Table 1. DECT Application Circuit Electrical Characteristics

RF frequency = 110.592MHz; IF frequency = 9.8MHz; RF level = -45dBm; FM modulation = 100kHz with ±288kHz peak deviation.

| SYMBOL | PARAMETER | TEST CONDITIONS | TYPICAL | UNITS |
|---|-----------------------------|---------------------------------------|---------|-------------------|
| Mixer/Osc section (ext LO = 160mV_{RMS}) | | | | |
| PG | Conversion power gain | | 13 | dB |
| NF | Noise Figure at 110MHz | | 12 | dB |
| IIP3 | Third order input intercept | Matched f1 = 110.592; f2 = 110.892MHz | -15 | dBm |
| R _{IN} | RF input resistance | | 690 | Ω |
| C _{IN} | RF input capacitance | | 3.6 | pF |
| IF section | | | | |
| | IF amp gain | 330Ω load | 38 | dB |
| | Limiter amp gain | 330Ω load | 54 | dB |
| | Data level | R _{LOAD} = 3kΩ | 130 | mV _{RMS} |
| | 3dB data bandwidth | | 700 | kHz |
| RF/IF section (internal LO) | | | | |
| | System RSSI output | RF level = -10dBm | 1.4 | V |
| | System S/N ¹ | RF level = -83dBm | 10 | dB |

NOTE:

- 10dB S/N corresponds to BER = 10⁻³.

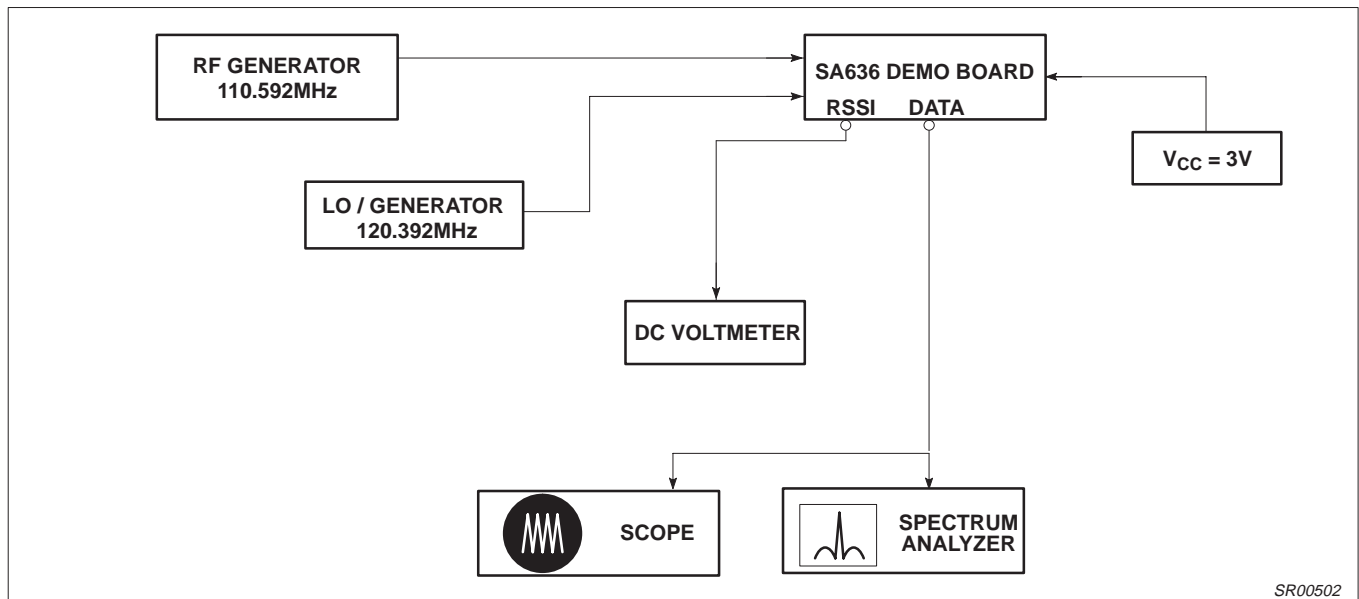

SR00502

Figure 11. SA636 Application Circuit Test Set Up

NOTES:

1. RF generator: Set your RF generator at 110.592MHz, use a 100kHz modulation frequency and a ±288kHz deviation.
2. Layout: The layout is very critical in the performance of the receiver. We highly recommend our demo board layout.
3. RSSI: The smallest RSSI voltage (i.e., when no RF input is present and the input is terminated) is a measure of the quality of the layout and design. If the lowest RSSI voltage is 500mV or higher, it means the receiver is in regenerative mode. In that case, the receiver sensitivity will be worse than expected.
4. Supply bypass and shielding: All of the inductors, the quad tank, and their shield must be grounded. A 0.1µF bypass capacitor on the supply pin improves sensitivity.

Low voltage high performance mixer FM IF system with high-speed RSSI

SA636

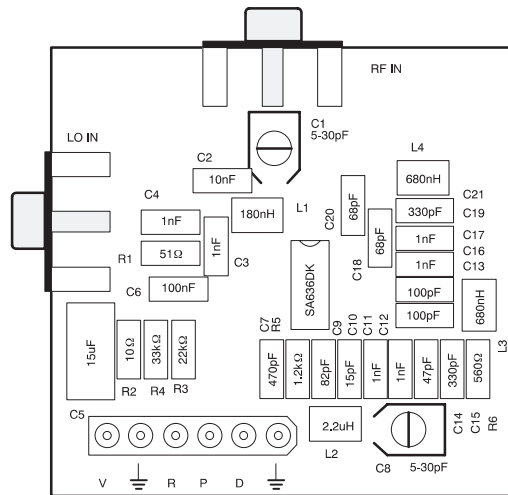

TOP SILK SCREEN (SSOP)

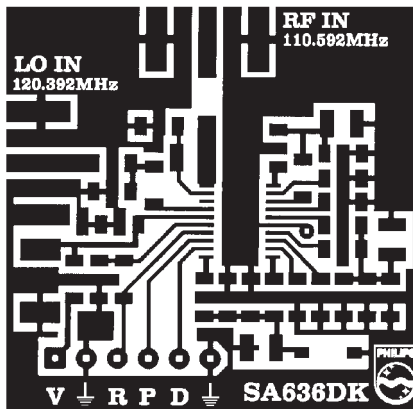

TOP VIEW (SSOP)

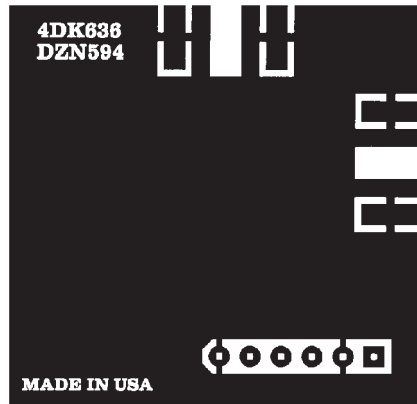

BOTTOM VIEW (SSOP)

Figure 12. SA636 Demoboard Layout (Not Actual Size)

Low voltage high performance mixer FM IF system with high-speed RSSI

SA636

CIRCUIT DESCRIPTION

The SA636 is an IF signal processing system suitable for second IF or single conversion systems with input frequency as high as 1GHz. The bandwidth of the IF amplifier is about 40MHz, with 38dB of gain from a 50Ω source. The bandwidth of the limiter is about 28MHz with about 54dB of gain from a 50Ω source. However, the gain/bandwidth distribution is optimized for 10.7MHz, 330Ω source applications. The overall system is well-suited to battery operation as well as high performance and high quality products of all types, such as cordless and cellular hand-held phones.

The input stage is a Gilbert cell mixer with oscillator. Typical mixer characteristics include a noise figure of 14dB, conversion gain of 11dB, and input third-order intercept of -16dBm. The oscillator will operate in excess of 1GHz in L/C tank configurations. Hartley or Colpitts circuits can be used up to 100MHz for xtal configurations. Butler oscillators are recommended for xtal configurations up to 150MHz.

The output of the mixer is internally loaded with a 330Ω resistor permitting direct connection to a 10.7MHz ceramic filter for narrowband applications. The input resistance of the limiting IF amplifiers is also 330Ω. With most 10.7MHz ceramic filters and many crystal filters, no impedance matching network is necessary. For applications requiring wideband IF filtering, such as DECT, external LC filters are used (see Figure 10). To achieve optimum linearity of the log signal strength indicator, there must be a 6dB(v) insertion loss between the first and second IF stages. If the IF filter

or interstage network does not cause 6dB(v) insertion loss, a fixed or variable resistor can be added between the first IF output (Pin 16) and the interstage network.

The signal from the second limiting amplifier goes to a Gilbert cell quadrature detector. One port of the Gilbert cell is internally driven by the IF. The other output of the IF is AC-coupled to a tuned quadrature network. This signal, which now has a 90° phase relationship to the internal signal, drives the other port of the multiplier cell.

Overall, the IF section has a gain of 90dB. For operation at intermediate frequency at 10.7MHz. Special care must be given to layout, termination, and interstage loss to avoid instability.

The demodulated output (DATA) of the quadrature is a voltage output. This output is designed to handle a minimum bandwidth of 600kHz. This is designed to demodulate wideband data, such as in DECT applications.

A Receive Signal Strength Indicator (RSSI) completes the circuitry. The output range is greater than 90dB and is temperature compensated. This log signal strength indicator exceeds the criteria for AMPS or TACS cellular telephone, DECT and RCR-28 cordless telephone. This signal drives an internal op amp. The op amp is capable of rail-to-rail output. It can be used for gain, filtering, or 2nd-order temperature compensation of the RSSI, if needed.

NOTE: $\text{dB(v)} = 20 \log V_{\text{OUT}}/V_{\text{IN}}$

Low voltage high performance mixer FM IF system with high-speed RSSI

SA636

SO20: plastic small outline package; 20 leads; body width 7.5 mm

SOT163-1

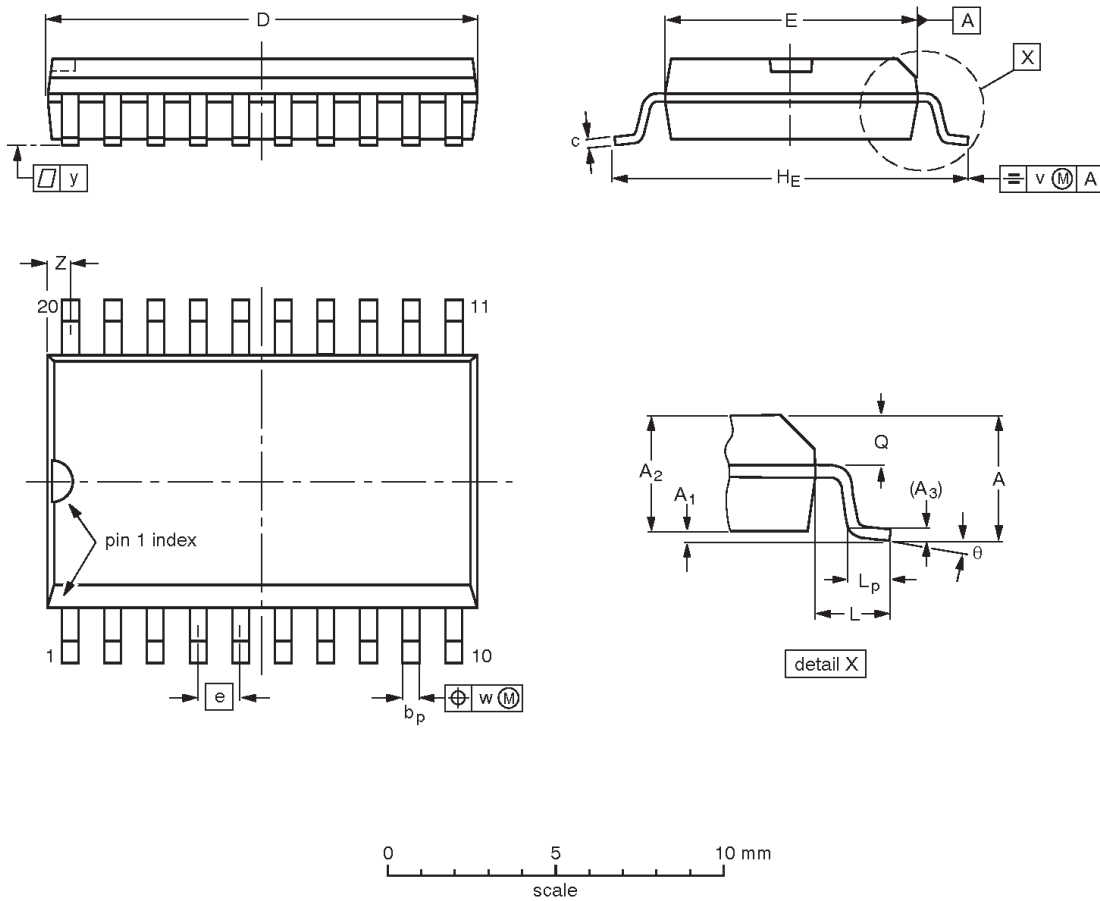

DIMENSIONS (inch dimensions are derived from the original mm dimensions)

| UNIT | A max. | A ₁ | A ₂ | A ₃ | b _p | c | D ⁽¹⁾ | E ⁽¹⁾ | e | H _E | L | L _p | Q | v | w | y | Z ⁽¹⁾ | θ |
|--------|--------------|----------------|----------------|----------------|----------------|----------------|------------------|------------------|-------|----------------|-------|----------------|----------------|------|------|-------|------------------|----------|
| mm | 2.65 0.10 | 0.30 0.10 | 2.45 2.25 | 0.25 | 0.49 0.36 | 0.32 0.23 | 13.0 12.6 | 7.6 7.4 | 1.27 | 10.65 10.00 | 1.4 | 1.1 0.4 | 1.1 1.0 | 0.25 | 0.25 | 0.1 | 0.9 0.4 | 8° 0° |
| inches | 0.10 | 0.012 0.004 | 0.096 0.089 | 0.01 | 0.019 0.014 | 0.013 0.009 | 0.51 0.49 | 0.30 0.29 | 0.050 | 0.42 0.39 | 0.055 | 0.043 0.016 | 0.043 0.039 | 0.01 | 0.01 | 0.004 | 0.035 0.016 | |

Note

1. Plastic or metal protrusions of 0.15 mm maximum per side are not included.

| OUTLINE VERSION | REFERENCES | | | EUROPEAN PROJECTION | ISSUE DATE |
|-----------------|------------|----------|------|---------------------|-----------------------|
| | IEC | JEDEC | EIAJ | | |
| SOT163-1 | 075E04 | MS-013AC | | | -92-11-17 95-01-24 |

Low voltage high performance mixer FM IF system with high-speed RSSI

SA636

DEFINITIONS

| Data Sheet Identification | Product Status | Definition |
|----------------------------------|-------------------------------|--|
| <i>Objective Specification</i> | Formative or in Design | This data sheet contains the design target or goal specifications for product development. Specifications may change in any manner without notice. |
| <i>Preliminary Specification</i> | Preproduction Product | This data sheet contains preliminary data, and supplementary data will be published at a later date. Philips Semiconductors reserves the right to make changes at any time without notice in order to improve design and supply the best possible product. |
| <i>Product Specification</i> | Full Production | This data sheet contains Final Specifications. Philips Semiconductors reserves the right to make changes at any time without notice, in order to improve design and supply the best possible product. |

Philips Semiconductors and Philips Electronics North America Corporation reserve the right to make changes, without notice, in the products, including circuits, standard cells, and/or software, described or contained herein in order to improve design and/or performance. Philips Semiconductors assumes no responsibility or liability for the use of any of these products, conveys no license or title under any patent, copyright, or mask work right to these products, and makes no representations or warranties that these products are free from patent, copyright, or mask work right infringement, unless otherwise specified. Applications that are described herein for any of these products are for illustrative purposes only. Philips Semiconductors makes no representation or warranty that such applications will be suitable for the specified use without further testing or modification.

LIFE SUPPORT APPLICATIONS

Philips Semiconductors and Philips Electronics North America Corporation Products are not designed for use in life support appliances, devices, or systems where malfunction of a Philips Semiconductors and Philips Electronics North America Corporation Product can reasonably be expected to result in a personal injury. Philips Semiconductors and Philips Electronics North America Corporation customers using or selling Philips Semiconductors and Philips Electronics North America Corporation Products for use in such applications do so at their own risk and agree to fully indemnify Philips Semiconductors and Philips Electronics North America Corporation for any damages resulting from such improper use or sale.