

# Divide by: 64/65/72 triple modulus low power ECL prescaler

SA702

## DESCRIPTION

The SA702 triple modulus (Divide By 64/65/72) low power ECL prescaler is used in synthesizer systems to achieve low phase lock time, broad operating range, high reference frequency and small frequency step sizes. The minimum supply voltage is 2.7V and is compatible with the CMOS UMA1005 synthesizer from Philips and other logic circuits. The low supply current allows application in battery operated low-power equipment. Maximum input signal frequency is 1.1GHz for cellular and other land mobile applications. There is no lower frequency limit due to a fully static design. The circuit is implemented in ECL technology on the QUBiC process. The circuit will be available in an 8-pin SO package with 150 mil package width and in 8-pin dual in-line plastic package.

## FEATURES

- Low voltage operation
- Low current consumption
- Operation up to 1.1GHz
- ESD hardened

## APPLICATIONS

- Cellular phones
- Cordless phones
- RF LANs
- Test and measurement
- Military radio
- VHF/UHF mobile radio
- VHF/UHF hand-held radio

## PIN CONFIGURATION

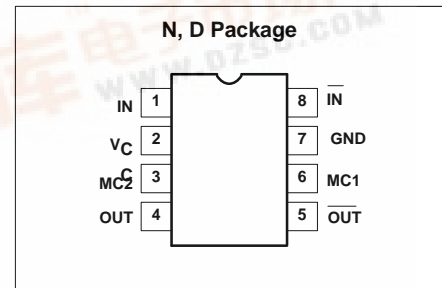

## ORDERING INFORMATION

DESCRIPTION	TEMPERATURE RANGE	ORDER CODE	DWG #
8-Pin Plastic Dual In-Line Package (DIP)	-40 to +85°C	SA702N	0404B
8-Pin Plastic Small Outline (SO) package (Surface-mount)	-40 to +85°C	SA702D	0174C

## ABSOLUTE MAXIMUM RATINGS

SYMBOL	PARAMETER	RATING	UNITS	
V <sub>CC</sub>	Supply voltage	-0.3 to +7.0	V	
V <sub>IN</sub>	Voltage applied to any other pin	-0.3 to (V <sub>CC</sub> + 0.3)	V	
I <sub>O</sub>	Output current	10	mA	
T <sub>STG</sub>	Storage temperature range	-65 to +125	°C	
T <sub>A</sub>	Operating ambient temperature range	-55 to +125	°C	
θ <sub>JA</sub>	Thermal impedance	D package N package	158 108	°C/W

# Divide by: 64/65/72 triple modulus low power ECL prescaler

SA702

## BLOCK DIAGRAM

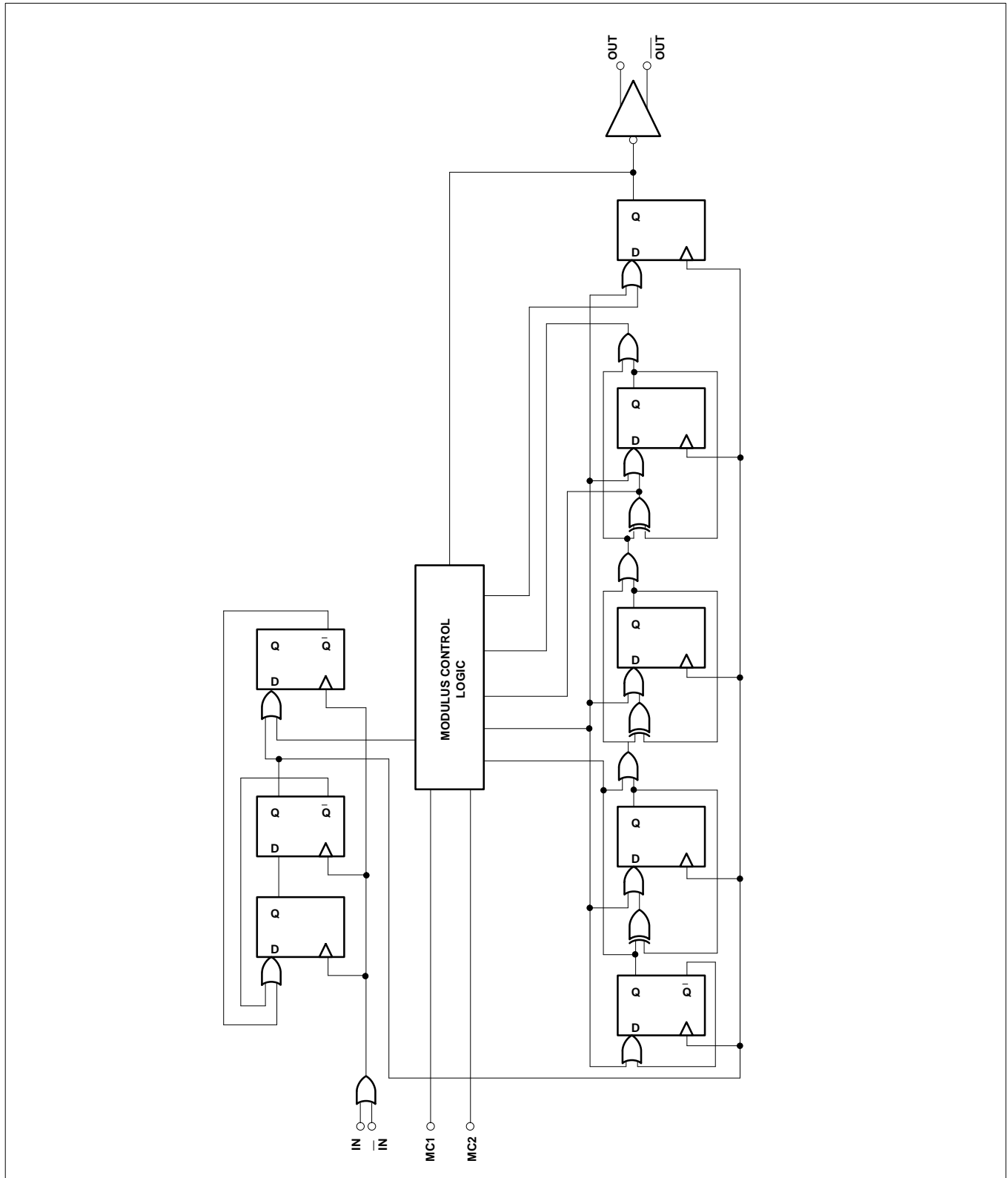

# Divide by: 64/65/72 triple modulus low power ECL prescaler

SA702

## DC ELECTRICAL CHARACTERISTICS

The following DC specifications are valid for  $T_A = 25^\circ\text{C}$  and  $V_{CC} = 3.0\text{V}$ ; unless otherwise stated. Test circuit Figure 1.

SYMBOL	PARAMETER	TEST CONDITIONS	LIMITS			UNITS
			MIN	TYP	MAX	
$V_{CC}$	Power supply voltage range	$f_{IN} = 1\text{GHz}$ , input level = 0dBm	2.7		6.0	V
$I_{CC}$	Supply current	No load		4.5		mA
$V_{OH}$	Output high level	$I_{OUT} = 1.2\text{mA}$	$V_{CC}-1.4$			V
$V_{OL}$	Output low level			$V_{CC}-2.6$		V
$V_{IH}$	MC1 input high threshold		2.0		$V_{CC}$	V
$V_{IL}$	MC1 input low threshold		-0.3		0.8	V
$V_{IH}$	MC2 input high threshold		2.0		$V_{CC}$	V
$V_{IL}$	MC2 input low threshold		-0.3		0.8	V
$I_{IH}$	MC1 input high current	$V_{MC1} = V_{CC} = 6\text{V}$		0.1	50	$\mu\text{A}$
$I_{IL}$	MC1 input low current	$V_{MC1} = 0\text{V}$ , $V_{CC} = 6\text{V}$	-100	-30		$\mu\text{A}$
$I_{IH}$	MC2 input high current	$V_{MC2} = V_{CC} = 6\text{V}$		0.1	50	$\mu\text{A}$
$I_{IL}$	MC2 input low current	$V_{MC2} = 0\text{V}$ , $V_{CC} = 6\text{V}$	-100	-30		$\mu\text{A}$

## AC ELECTRICAL CHARACTERISTICS

These AC specifications are valid for  $f_{IN} = 1\text{GHz}$ , input level = 0dBm,  $V_{CC} = 3.0\text{V}$  and  $T_A = 25^\circ\text{C}$ ; unless otherwise stated. Test circuit Fig. 1.

SYMBOL	PARAMETER	TEST CONDITIONS	LIMITS			UNITS
			MIN	TYP	MAX	
$V_{IN}$	Input signal amplitude <sup>1</sup>	1000pF input coupling	0.05		2.0	$V_{P-P}$
$f_{IN}$	Input signal frequency	Direct coupled input <sup>2</sup>	0		1.1	GHz
		1000pF input coupling			1.1	GHz
$R_{ID}$	Differential input resistance	DC measurement		5		$k\Omega$
$V_O$	Output voltage	$V_{CC} = 5.0\text{V}$		1.6		$V_{P-P}$
		$V_{CC} = 3.0\text{V}$		1.2		$V_{P-P}$
$t_S$	Modulus set-up time <sup>1</sup>				5	ns
$t_H$	Modulus hold time <sup>1</sup>				0	ns
$t_{PD}$	Propagation time			10		ns

### NOTES:

- Maximum limit is not tested, however, it is guaranteed by design and characterization.
- For  $f_{IN} < 50\text{MHz}$ , minimum input slew rate of  $32\text{V}/\mu\text{s}$  is required.

## DESCRIPTION OF OPERATION

The SA702 comprises a frequency divider circuit implemented using a divide by 4 or 5 synchronous prescaler followed by a 5 stage synchronous counter, see BLOCK DIAGRAM. The normal operating mode is for MC1 (Modulus Control) to be set high and MC2 input to be set low in which case the circuit comprises a divide by 64. For divide by 65 the MC1 signal is forced low, causing the prescaler circuit to switch into divide by 5 operation for the last cycle of the synchronous counter. For divide by 72, MC2 is set high configuring the prescaler to divide by 4 and the counter to divide by 18. A truth table for the modulus values is given below:

Table 1.

Modulus	MC1	MC2
64	1	0
65	0	0
72	0	1
72	1	1

For minimization of propagation delay effects, the second divider circuit is synchronous to the divide by 4/5 stage output.

The prescaler input is positive edge sensitive, and the output at the final count is a falling edge with propagation delay  $t_{PD}$  relative to the input. The rising edge of the output occurs at the count 32 with delay  $t_{PD}$ .

The MC1 and MC2 inputs are TTL compatible threshold inputs operating at a

reduced input current. CMOS and low voltage interface capability are allowed.

The prescaler input is differential and ECL compatible. The output is differential ECL compatible.

Divide by: 64/65/72 triple modulus low power  
ECL prescaler

SA702

AC TIMING CHARACTERISTICS

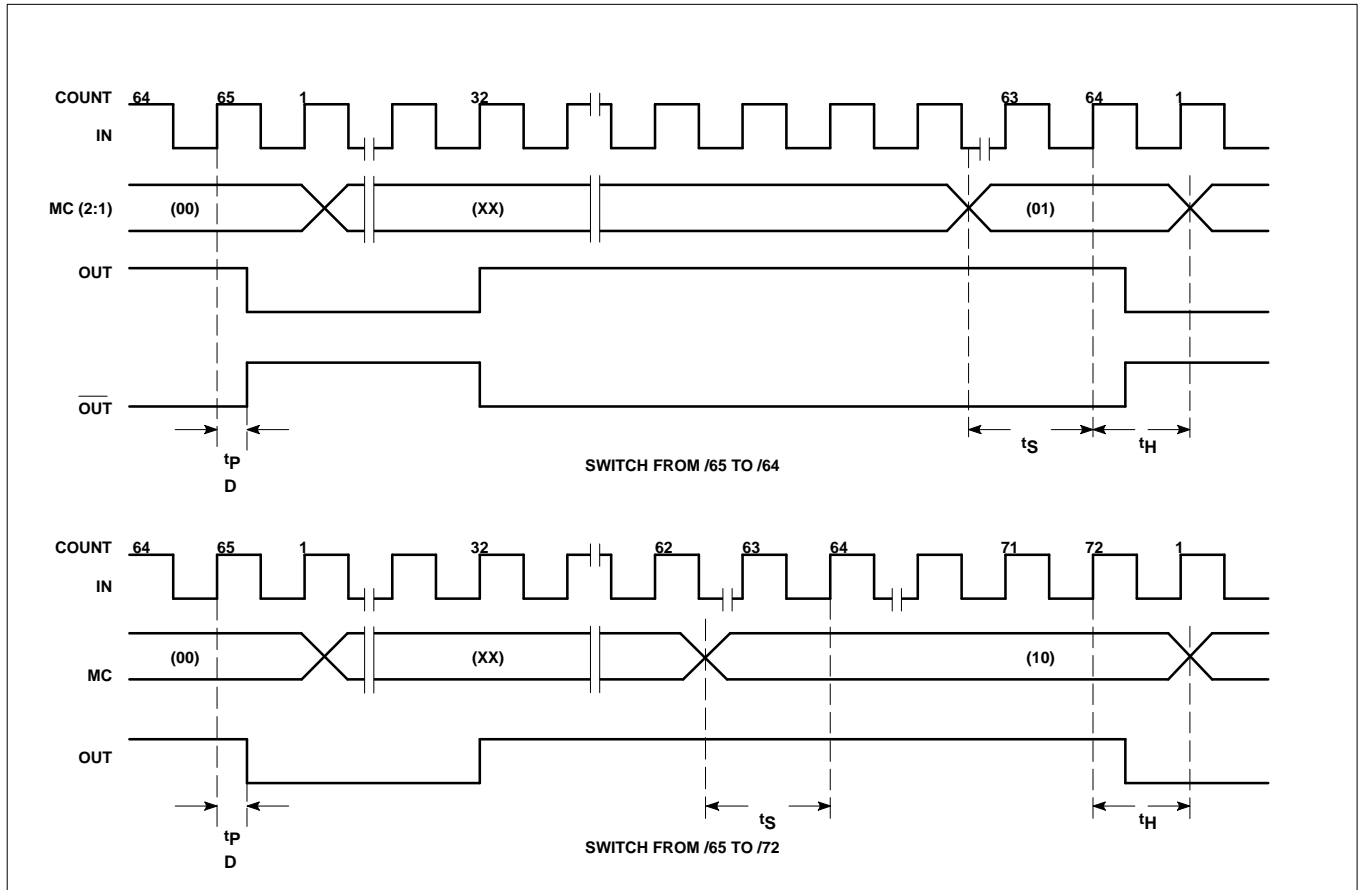

# Divide by: 64/65/72 triple modulus low power ECL prescaler

SA702

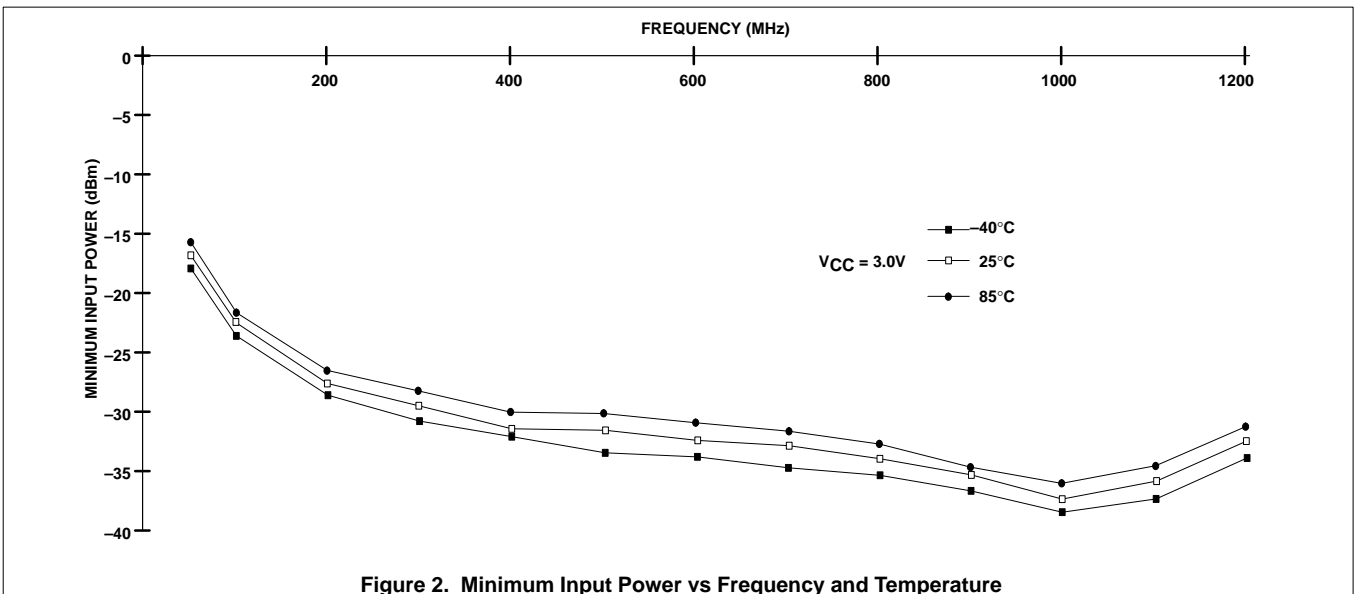
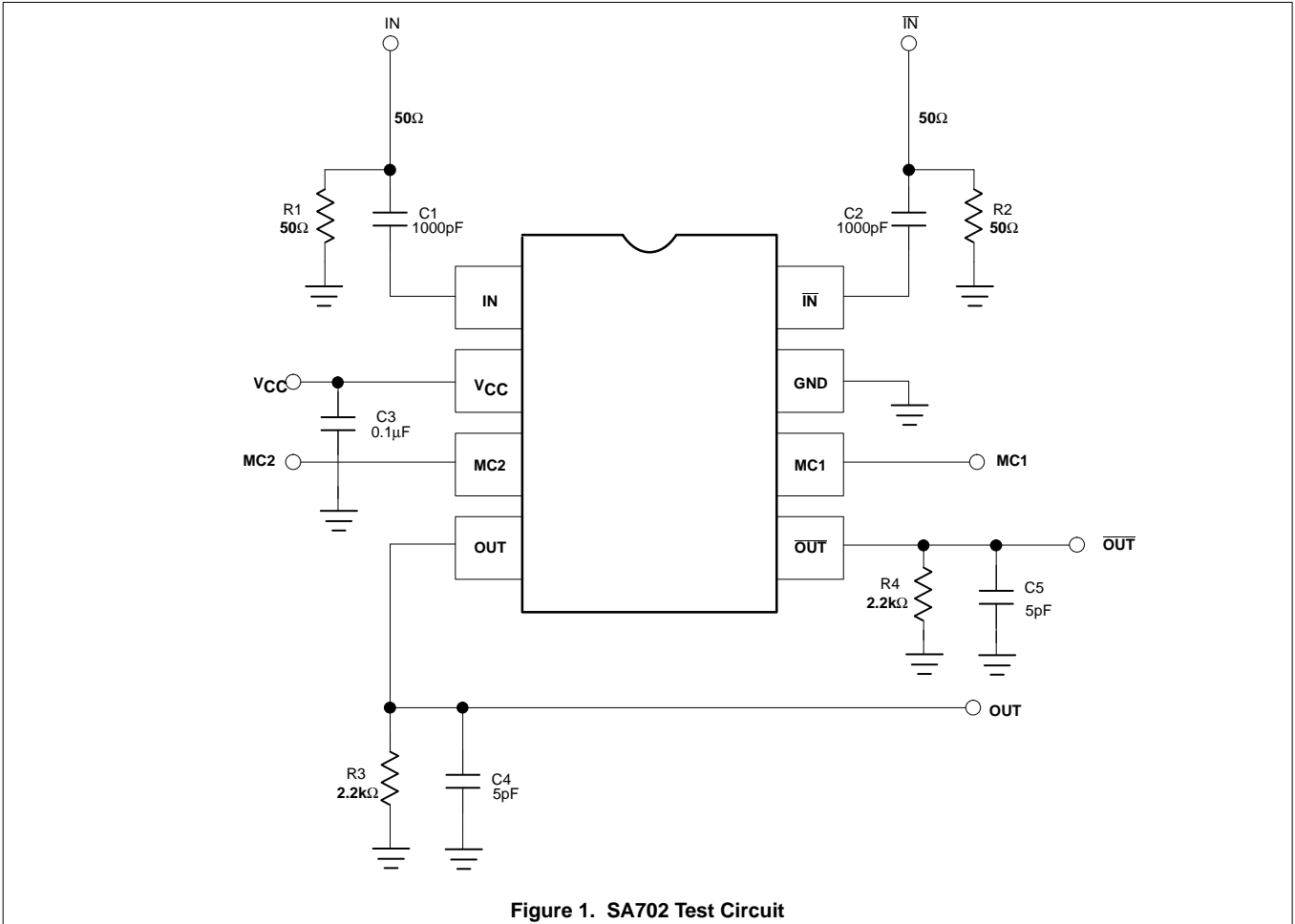

Divide by: 64/65/72 triple modulus low power  
ECL prescaler

SA702

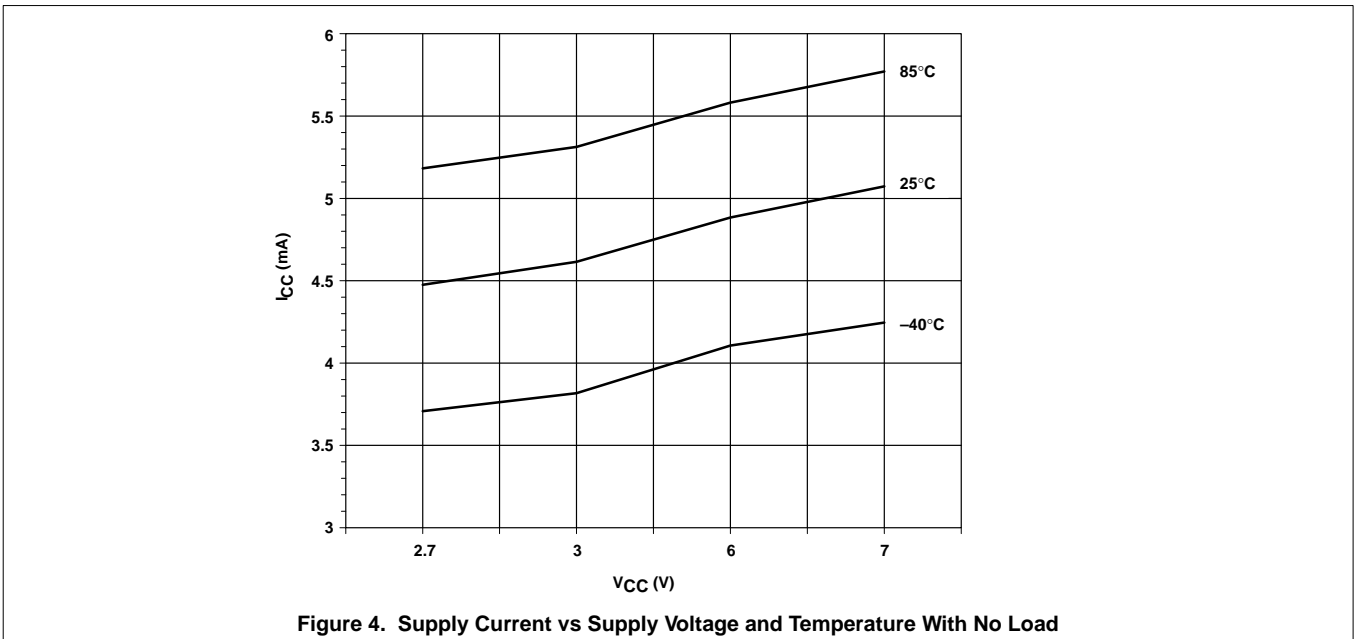
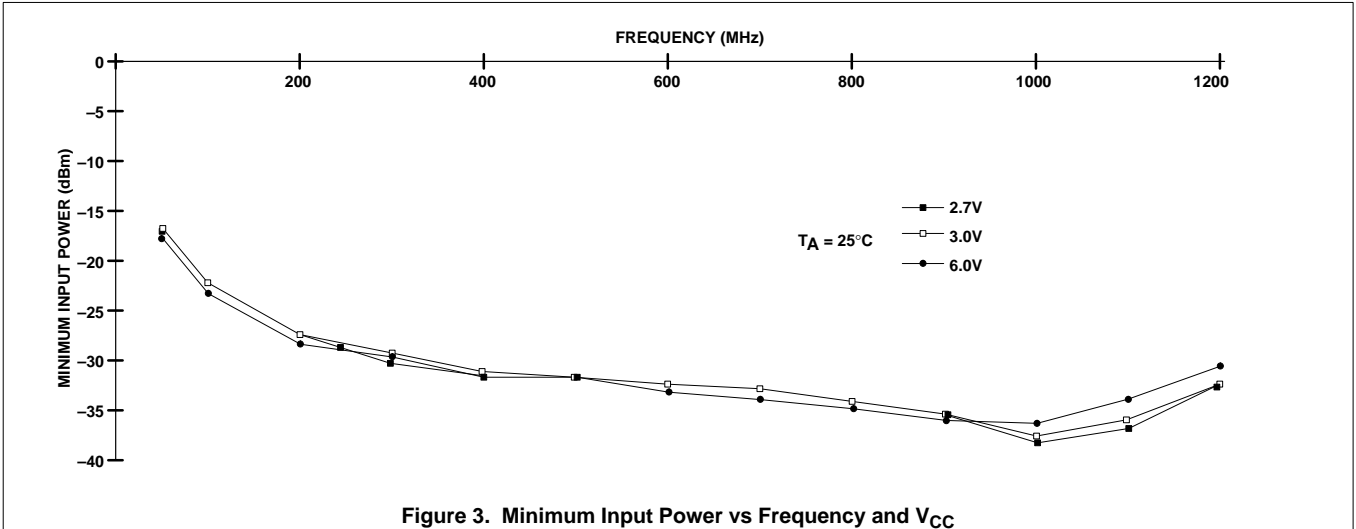

Divide by: 64/65/72 triple modulus low power  
ECL prescaler

SA702

