

<b>SB6540</b>	<b>P.1</b>
LOW FREQUENCY EL DRIVER IC	

## GENERAL DESCRIPTION

The SB6540 is specially designed as a low frequency low power Electroluminescent Lamp Driver IC. Built-in RC OSC, transistors and only requires 2~3 external components. It is specially designed for products of EMI concern.

## FEATURE

- \* BIPLOR TECHNOLOGY
- \* OPERATING VOLTAGE :  
2.2V ~ 5.0V DC
- \* TOTAL SUPPLY CURRENT :  
20mA (at V<sub>dd</sub> = 3 V)
- \* LOW FREQUENCY 200 Hz
- \* Built-in RC OSC & TRANSISTORS

## APPLICATIONS

- \* CELLULAR PHONE LCD BACKLIGHT
- \* CORDLESS PHONE (DECT, 900MHz, 46/49MHz ..) LCD BACKLIGHT
- \* WATCH BACKLIGHT
- \* PAGER BACKLIGHT
- \* SMALL SIZE DISPLAY DATABACK BACKLIGHT
- \* OTHER PORTABLE PRODUCTS WITH SMALL SIZE LCD BACKLIGHT

## SPECIFICATION

(T=25°C, V<sub>dd</sub>=3.0V, Lamp Capacitance=3000pF, Coil=12mH(R=24Ω), C<sub>osc</sub>=282pF)

PARAMETER	MIN	MAX	UNIT	CONDITIONS
Supply Voltage	2.2	5.0	V	
Total Supply Current		20	mA	V <sub>dd</sub> =3.0V; H <sub>ON</sub> =3.0V
Quiescent Supply Current		200	nA	V <sub>dd</sub> =3.0V; H <sub>ON</sub> =0V
H <sub>ON</sub> Voltage On	V <sub>dd</sub> -0.5	V <sub>dd</sub>	V	
H <sub>ON</sub> Current On		60	μA	V <sub>dd</sub> =3.0V
H <sub>ON</sub> Voltage Off		V <sub>dd</sub> -2	V	V <sub>dd</sub> =3.0V
Inductor Drive Peak Current		60	mA	
Lamp Output				
Differential Voltage	110		V <sub>PP</sub>	V <sub>dd</sub> =3.0V
Frequency	200	400	Hz	V <sub>dd</sub> =3.0V



<b>SB6540</b>	<b>P.2</b>
<b>LOW FREQUENCY EL DRIVER IC</b>	

**APPLICATION CIRCUIT – HOLD RELEASE**

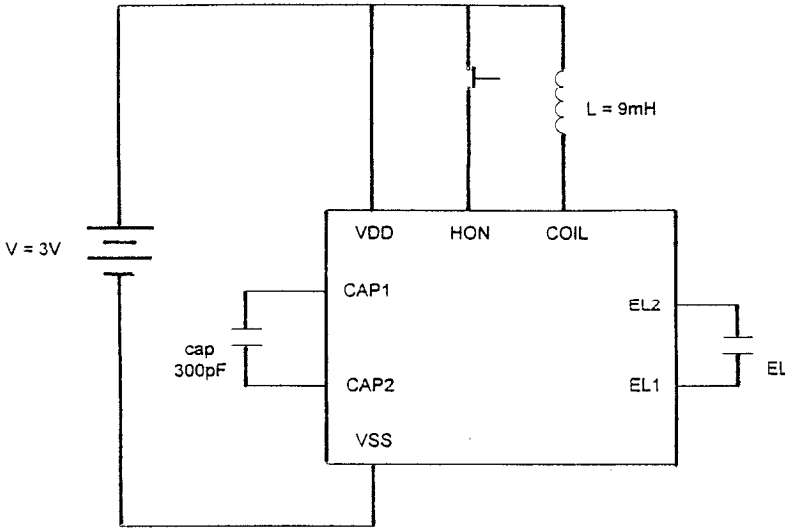

**APPLICATION CIRCUIT – HOLD DELAY**

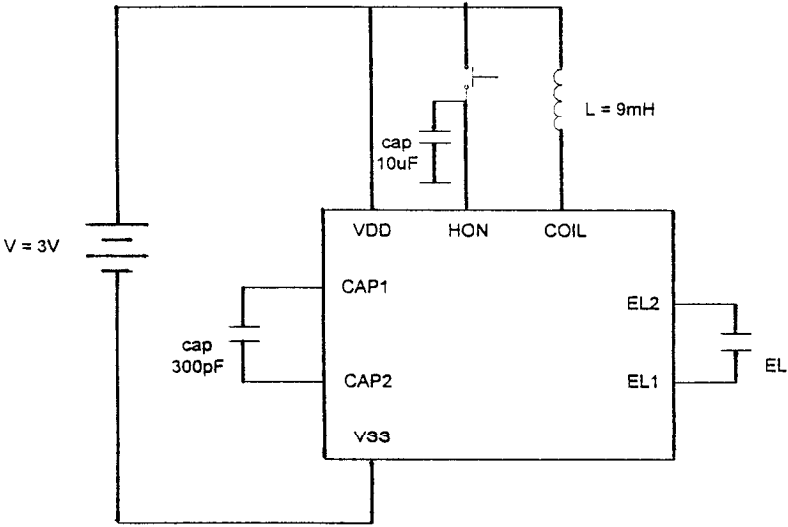

<b>SB6540</b>	<b>P.3</b>
<b>LOW FREQUENCY EL DRIVER IC</b>	

## BOUNDING DIAGRAM

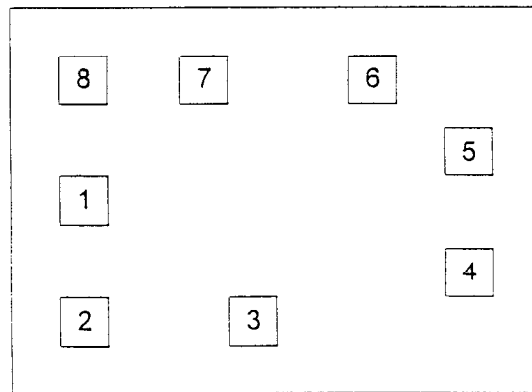

### Pad Allocation

Pad No.	Pad name	X (um)	Y(um)
1	HON	-787.5	128.5
2	VSS	-782.5	-668.5
3	COIL	-301.5	-668.5
4	EL2	793.5	98.5
5	EL1	793.5	311.5
6	VDD	-84.5	671.5
7	CAP1	-508.5	670.5
8	CAP2	793.5	98.5

Note:

1. Dimensions are in Microns
2. Bounding pads are 125 X 125 typ
3. Outside dimensions are maximum, including acrite area
4. Pad centre coordinates are relative to die centre
5. Die size 1970 X 1970
6. Substrate must be connected to Vss
7. Die thickness is 450 microns

<b>SB6540</b>	<b>P.4</b>
<b>LOW FREQUENCY EL DRIVER IC</b>	

The following performance curves are intended to give the designer a relative scale from which to optimize specific applications. Absolute measurements may vary depending upon the brand of components chosen.

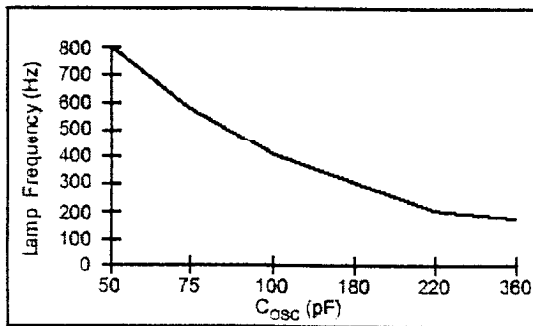

Lamp Frequency vs  $C_{osc}$   
 $V_{DD} = 3.0V$ ; Coil= 9mH, 35 $\Omega$ ; Lamp=1 sq. in.

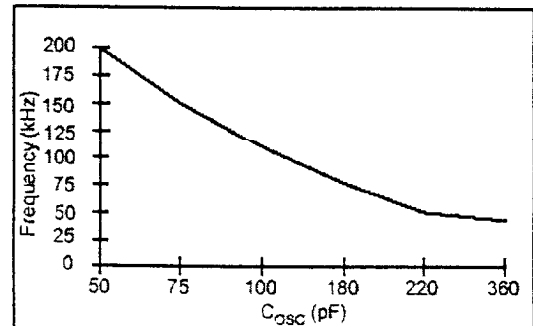

Oscillator Frequency vs  $C_{osc}$   
 $V_{DD} = 3.0V$ ; Coil= 9mH, 35 $\Omega$ ; Lamp=1 sq. in.

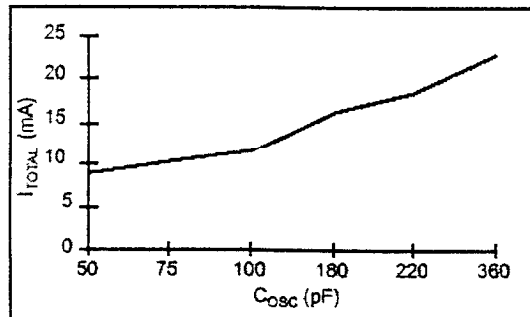

$I_{TOTAL}$  vs  $C_{osc}$   
 $V_{DD} = 3.0V$ ; Coil= 9mH, 35 $\Omega$ ; Lamp=1 sq. in.

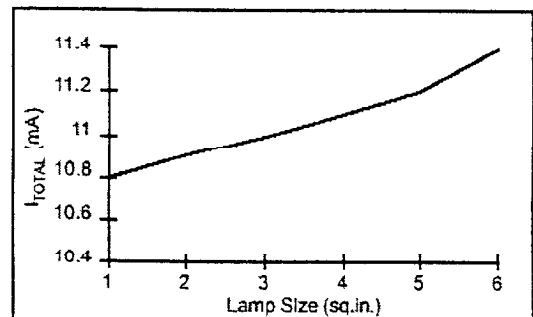

$I_{TOTAL}$  vs Lamp Size  
 $V_{DD} = 3.0V$ ; Coil= 9mH, 35 $\Omega$ ;  $C_{osc} = 180pF$

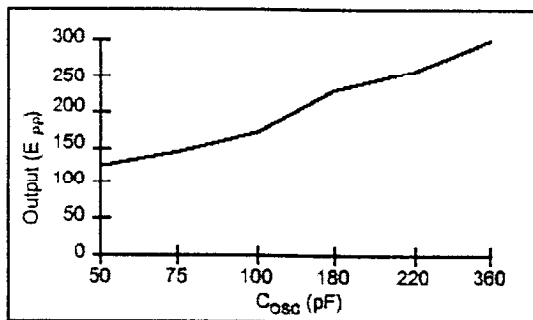

Output Voltage vs  $C_{osc}$   
 $V_{DD} = 3.0V$ ; Coil= 9mH, 35 $\Omega$ ; Lamp=1 sq. in.

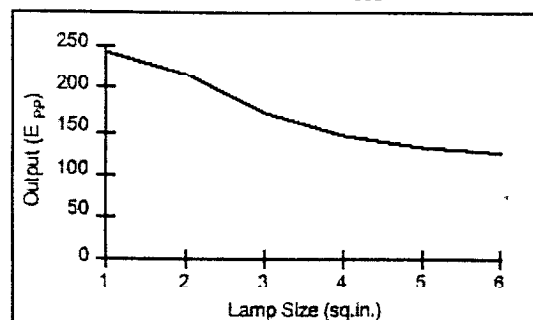

Output Voltage vs Lamp Size.  
 $V_{DD} = 3.0V$ ; Coil= 9mH, 35 $\Omega$ ;  $C_{osc} = 180pF$

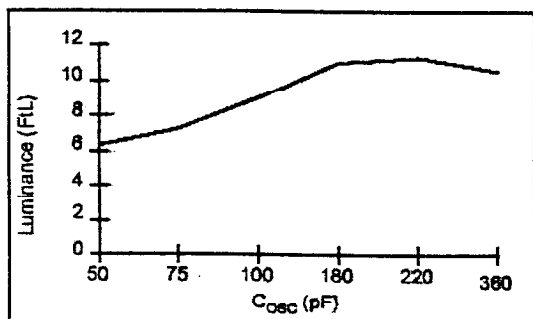

Luminance vs  $C_{osc}$

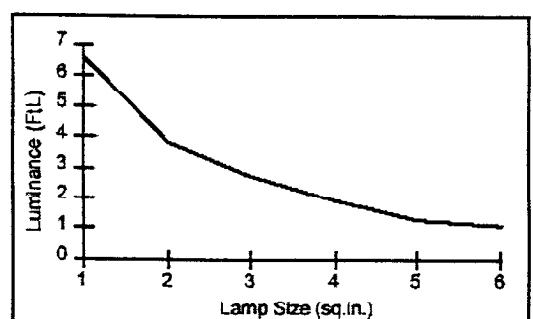

Luminance vs Lamp Size.

<b>SB6540</b>	<b>P.5</b>
<b>LOW FREQUENCY EL DRIVER IC</b>	

The following performance curves are intended to give the designer a relative scale from which to optimize specific applications. Absolute measurements may vary depending upon the brand of components chosen.

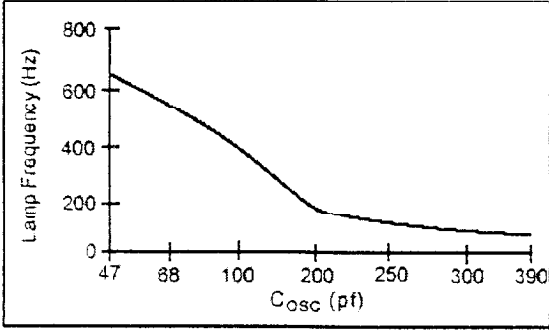

Lamp Frequency vs.  $C_{osc}$   
 $V_{DD} = 3.0V$ ; Coil= 5mH, 18 $\Omega$ ; Load=10nF

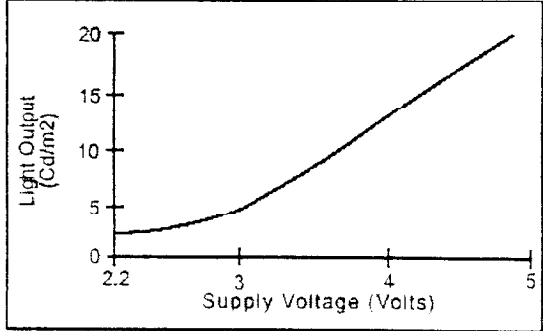

Luminance vs.  $V_{DD} = V_{coil}$   
 $V_{DD} = 3.0V$ ; Coil=5mH, 18 $\Omega$ ; Load=10nF

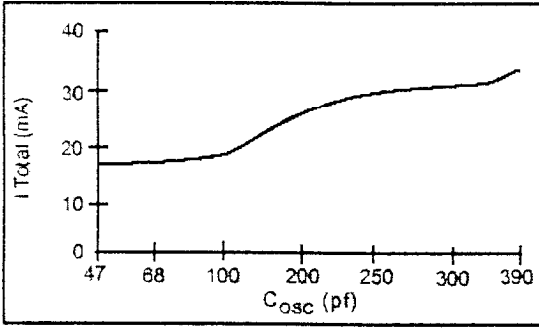

$I_{TOTAL}$  vs.  $C_{osc}$   
 $V_{DD} = 3.0V$ ; Coil= 5mH, 18 $\Omega$ ; Load=10nF

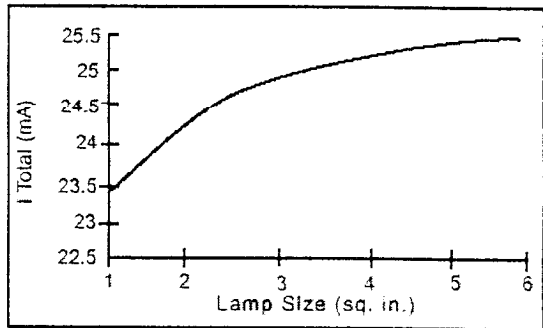

$I_{TOTAL}$  vs. Lamp Size  
 $V_{DD} = 3.0V$ ; Coil= 5mH, 18 $\Omega$ ;  $C_{osc} = 100pF$

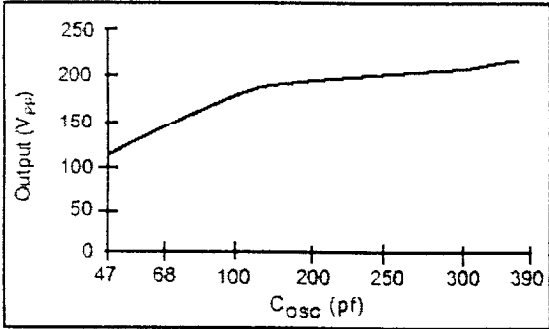

Output Voltage vs.  $C_{osc}$   
 $V_{DD} = 3.0V$ ; Coil= 5mH, 18 $\Omega$ ; Load=10nF

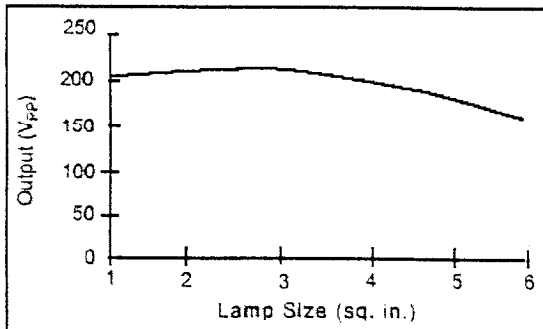

Output Voltage vs. Lamp Size.  
 $V_{DD} = 3.0V$ ; Coil= 5mH, 18 $\Omega$ ;  $C_{osc} = 100pF$

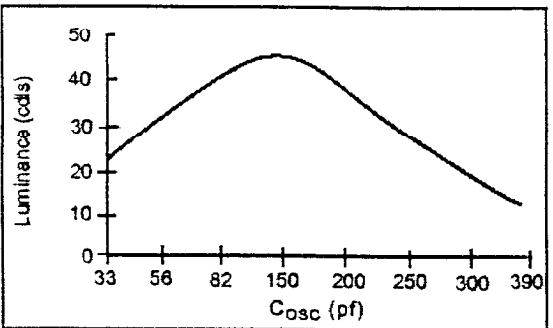

Luminance vs.  $C_{osc}$   
 $V_{DD} = 3.0V$ ; Coil= 5mH, 18 $\Omega$ ; Load=10nF

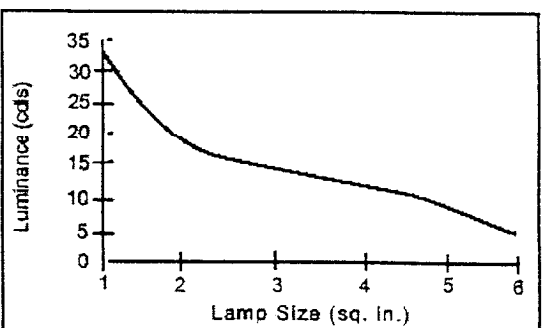

Luminance vs. Lamp Size.  
 $V_{DD} = 3.0V$ ; Coil= 5mH, 18 $\Omega$ ;  $C_{osc} = 100pF$

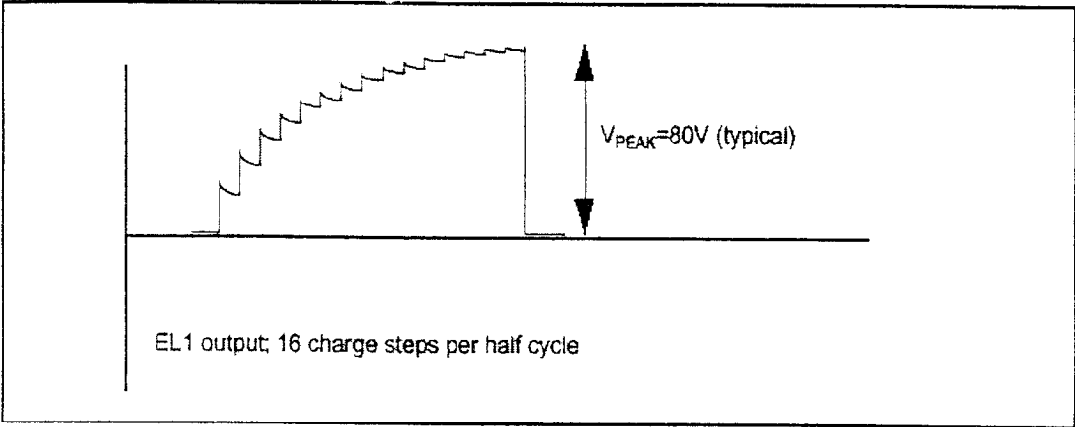

Figure 1. EL output voltage in discrete steps at EL1 output

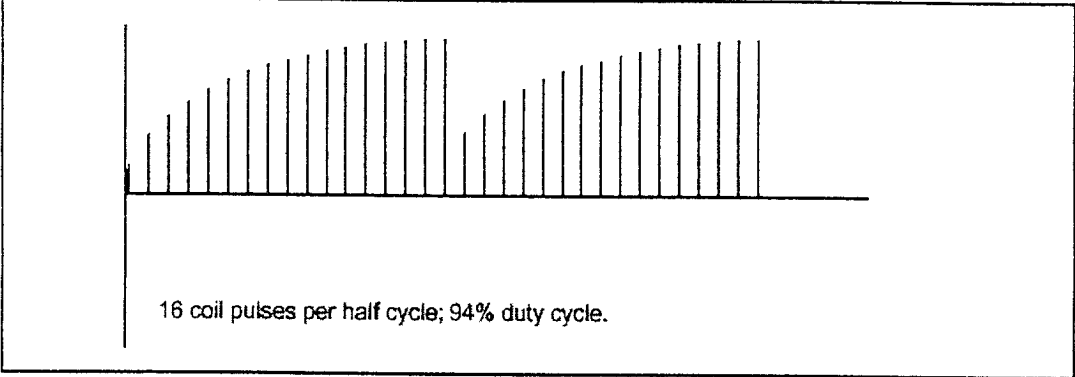

Figure 2. Voltage pulses released from the coil to the EL driver circuitry

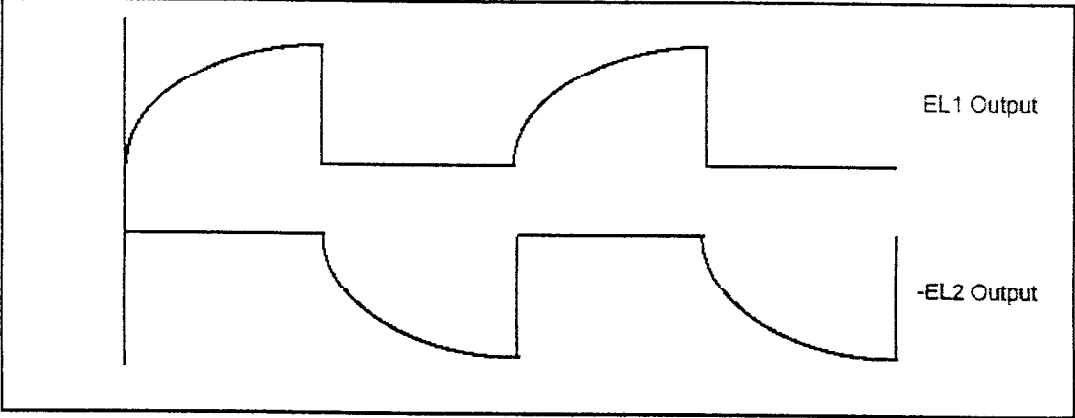

Figure 3. EL voltage waveforms from the EL1 and EL2 outputs

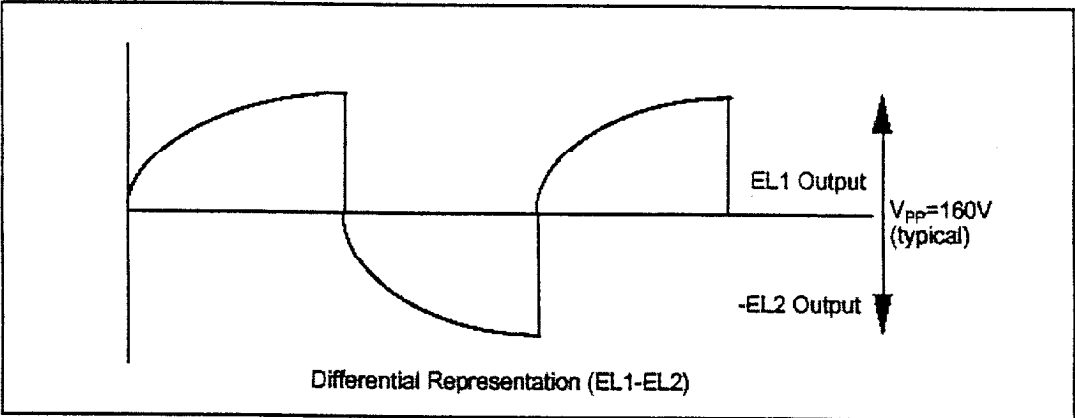

Figure 4. EL differential representation (EL1-EL2)

<b>SB6540</b>	<b>P.7</b>
<b>LOW FREQUENCY EL DRIVER IC</b>	

Experimental results of SB6540C against various sizes of EL elements

1. Testing conditions :
  - EL element size : 1" X 1.125" (1.125" square)
  - Supply voltage : 3V
  - Capacitance : 282pF**
  - 1.1 Inductance : 9mH, 37Ω
    - Output Voltage : 210Vp-p
    - Output Frequency: 185Hz
  - 1.2 **Inductance : 12mH, 30W**
    - Output Voltage : 220Vp-p
    - Output Frequency: 185Hz
  
2. Testing conditions :
  - EL element size : 2.125" X 1.125" (2.4" square)
  - Supply voltage : 3V
  - Capacitance : 282pF**
  - 2.1 Inductance : 9mH, 37Ω
    - Output Voltage : 170Vp-p
    - Output Frequency: 185Hz
  - 2.2 **Inductance : 12mH, 30W**
    - Output Voltage : 176Vp-p
    - Output Frequency: 185Hz
  
3. Testing conditions :
  - EL element size : 2.75" X 1.125" (3" square)
  - Supply voltage : 3V
  - Capacitance : 282pF**
  - 3.1 Inductance : 9mH, 37Ω
    - Output Voltage : 140Vp-p
    - Output Frequency: 185Hz
  - 3.2 **Inductance : 12mH, 30W**
    - Output Voltage : 156Vp-p
    - Output Frequency: 185Hz
  
4. Testing conditions :
  - EL element size : 3.625" X 1.125" (4.078" square)
  - Supply voltage : 3V
  - Capacitance : 282pF**
  - 4.1 Inductance : 9mH, 37Ω
    - Output Voltage : 140Vp-p
    - Output Frequency: 185Hz
  - 4.2 **Inductance : 12mH, 30W**
    - Output Voltage : 140Vp-p
    - Output Frequency: 185Hz
  
5. Testing conditions :
  - EL element size : 6.125" X 1.125" (6.89" square)
  - Supply voltage : 3V
  - Capacitance : 282pF**
  - 5.1 Inductance : 9mH, 37Ω
    - Output Voltage : 112Vp-p
    - Output Frequency: 185Hz
  - 5.2 **Inductance : 12mH, 30W**
    - Output Voltage : 112Vp-p
    - Output Frequency: 185Hz

---

TITLE: EXPERIMENTAL DATA of TESTING SB6540C with INDUCTOR **9mH 35ohms**

	$C_{osc}$	$I_L$	$V_{PP}$	Freq
1.	39pF	16.1mA	65V	1200Hz
2.	100pF	11.8mA	90V	555Hz
3.	150pF	12.9mA	110V	370Hz
4.	300pF	16.8mA	140V	212Hz
5.	560pF	21.0mA	140V	119Hz

TITLE: EXPERIMENTAL DATA of TESTING SB6540C with INDUCTOR **12mH 28ohms**

	$C_{osc}$	$I_L$	$V_{PP}$	Freq
1.	47pF	20.1mA	61V	961Hz
2.	94pF	16.4mA	80V	555Hz
3.	141pF	13.9mA	84V	392Hz
4.	188pF	13.6mA	96V	303Hz
5.	235pF	14.5mA	100V	238Hz
6.	282pF	15.2mA	108V	217Hz
7.	329pF	16.7mA	116V	178Hz
8.	376pF	17.7mA	120V	156Hz

TITLE: EXPERIMENTAL DATA of TESTING SB6540C with INDUCTOR **20mH 65ohms**

	$C_{osc}$	$I_L$	$V_{PP}$	Freq
1.	235pF	10.5mA	88V	250Hz
2.	282pF	10.5mA	94V	200Hz
3.	329pF	11.3mA	104V	172Hz
4.	376pF	12.0mA	108V	156Hz