



SBL10L25, SBLF10L25 & SBLB10L25

New Product

Vishay Semiconductors
formerly General Semiconductor

Low V_F Schottky Barrier Rectifier

Reverse Voltage 25V
Forward Current 10A

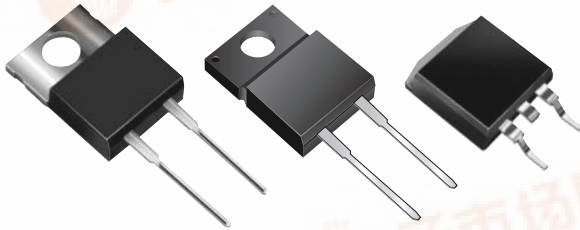

TO-220AC (SBL10L25)

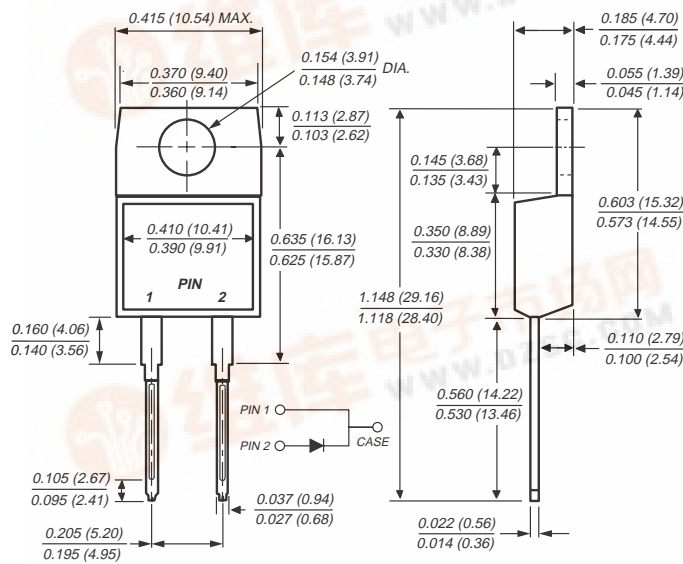

ITO-220AC (SBLF10L25)

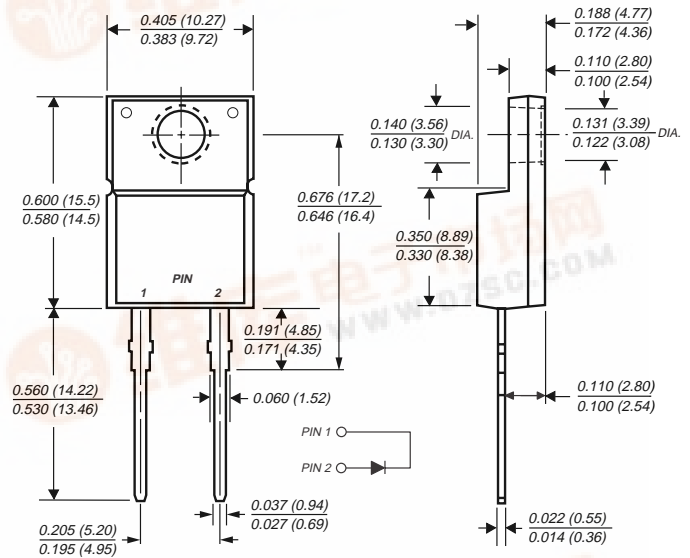

Mounting Pad Layout TO-263AB

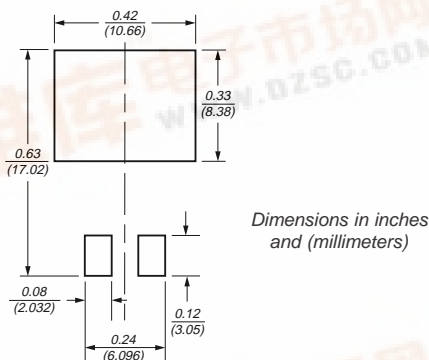

TO-263AB (SBLB10L25)

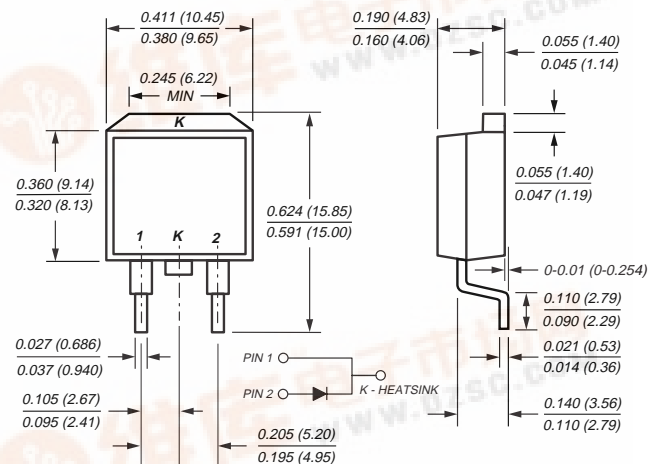

Features

- Plastic package has Underwriters Laboratory Flammability Classification 94V-0
- Dual rectifier construction, positive center tap
- Metal silicon junction, majority carrier conduction
- Low power loss, high efficiency
- Guardring for overvoltage protection
- For use in low voltage, high frequency inverters, free wheeling, and polarity protection applications

Mechanical Data

Case: JEDEC TO-220AC, ITO-220AC & TO-263AB molded plastic body

Terminals: Plated leads, solderable per MIL-STD-750, Method 2026

High temperature soldering guaranteed: 250°C/10 seconds, at terminals

Polarity: As marked

Mounting Position: Any

Mounting Torque: 10 in-lbs maximum

Weight: 0.08 oz., 2.24 g



SBL10L25, SBLF10L25 & SBLB10L25



Vishay Semiconductors
formerly General Semiconductor

Maximum Ratings (T_C = 25°C unless otherwise noted)

Parameter	Symbol	SBL10L25	Unit
Maximum repetitive peak reverse voltage	V _{RRM}	25	V
Working peak reverse voltage	V _{RWM}	18	V
Maximum DC blocking voltage	V _{DC}	25	V
Maximum average forward rectified current at T _C = 135°C	I _{F(AV)}	10	A
Peak forward surge current 8.3ms single half sine-wave superimposed on rated load (JEDEC Method)	I _{FSM}	240	A
Peak repetitive reverse current at t _p = 2μs, 1kHz	I _{RRM}	1.0	A
Voltage rate of change (rated V _R)	dv / dt	10,000	V / μs
Operating junction and storage temperature range	T _J , T _{STG}	-65 to +150	°C
RMS Isolation voltage (SBLF type only) from terminals to heatsink with t = 1 second, RH ≤ 30%	V _{ISOL}	4500 ⁽¹⁾ 3500 ⁽²⁾ 1500 ⁽³⁾	V

Electrical Characteristics (T_C = 25°C unless otherwise noted)

Parameter	Symbol	Value	Unit
Maximum instantaneous forward voltage ⁽⁴⁾	V _F	at I _F = 10A, T _J = 25°C 0.46	V
		at I _F = 10A, T _J = 125°C 0.35	
		at I _F = 20A, T _J = 25°C 0.55	
		at I _F = 20A, T _J = 125°C 0.48	
Maximum instantaneous reverse current at DC blocking voltage ⁽⁴⁾	I _R	T _J = 25°C 0.80 T _J = 125°C 260	mA

Thermal Characteristics (T_C = 25°C unless otherwise noted)

Parameter	Symbol	SBL	SBLF	SBLB	Unit
Typical thermal resistance from junction to case per leg	R _{θJC}	1.5	4.0	1.5	°C/W

Notes:

- (1) Clip mounting (on case), where lead does not overlap heatsink with 0.110" offset
- (2) Clip mounting (on case), where leads do overlap heatsink
- (3) Screw mounting with 4-40 screw, where washer diameter is ≤ 4.9 mm (0.19")
- (4) Pulse test: 380μs pulse width, 2% duty cycle

Ordering Information

Part Number	Case	Package Code	Package Option
SBL10L25	TO-220AC	45	Anti-static tube pack, 50/tube, 2K/carton
SBLF10L25	ITO-220AC	45	Anti-static tube pack, 50/tube, 2K/carton
SBLB10L25	TO-263AB	45	Anti-static tube pack, 50/tube, 2K/carton
		31	13" tape/reel, 800/reel, 4.8K/carton
		81	Anti-static 13" tape/reel, 800/reel, 4.8K/carton



Ratings and Characteristic Curves ($T_A = 25^\circ\text{C}$ unless otherwise noted)

Fig. 1 – Forward Current Derating Curve

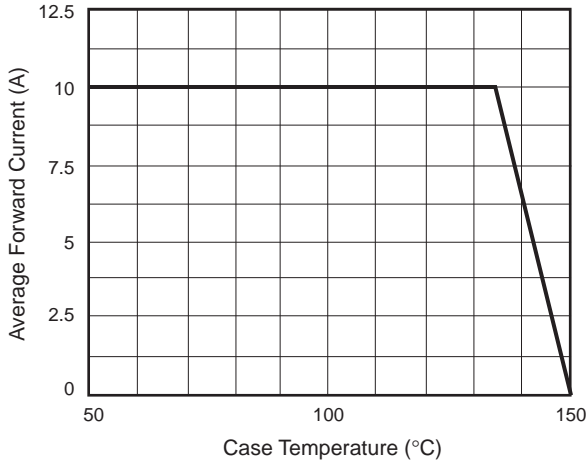

Fig. 2 – Typical Instantaneous Forward Characteristics

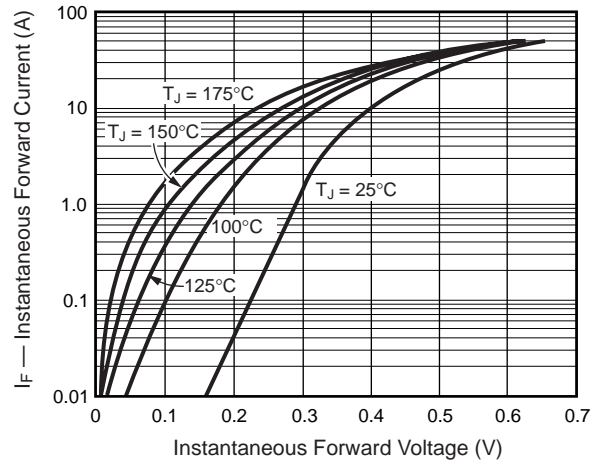

Fig. 3 – Typical Reverse Characteristics

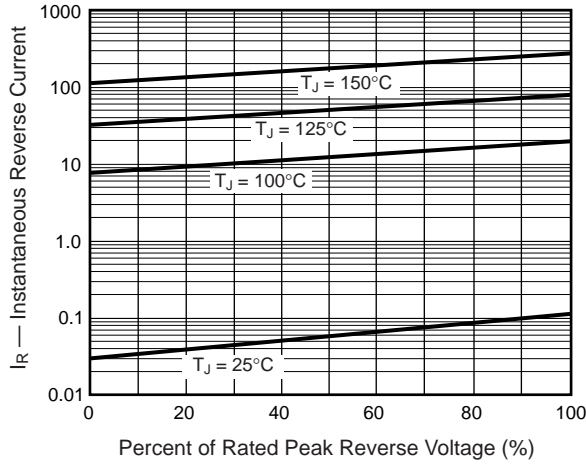

Fig. 4 – Typical Junction Capacitance

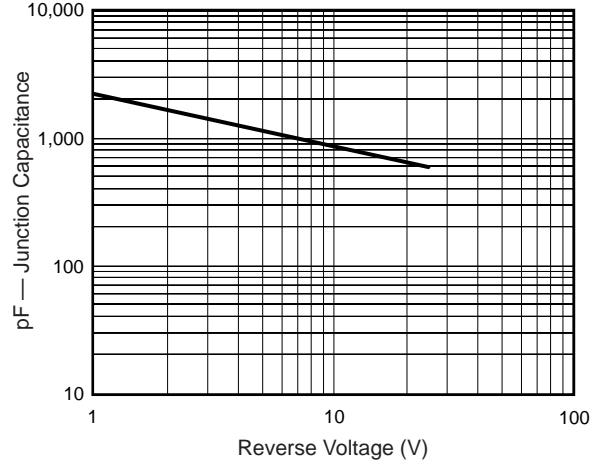

Fig. 5 – Typical Transient Thermal Impedance

