



# SBL830 - SBL860

## 8.0A SCHOTTKY BARRIER RECTIFIER

### Features

- Schottky Barrier Chip
- Guard Ring for Transient Protection
- Low Power Loss, High Efficiency
- High Current Capability, Low  $V_F$
- High Surge Capability
- For Use in Low Voltage, High Frequency Inverters, Free Wheeling, and Polarity Protection Applications
- Plastic Material: UL Flammability Classification Rating 94V-0

### Mechanical Data

- Case: Molded Plastic
- Terminals: Plated Leads, Solderable per MIL-STD-202, Method 208
- Polarity: See Diagram
- Weight: 2.3 grams (approx.)
- Mounting Position: Any
- Marking: Type Number

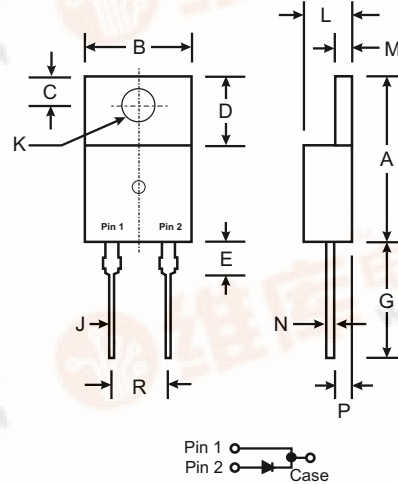

TO-220AC		
Dim	Min	Max
A	14.22	15.88
B	9.65	10.67
C	2.54	3.43
D	5.84	6.86
E	—	6.35
G	12.70	14.73
J	0.51	1.14
K	3.53 $\varnothing$	4.09 $\varnothing$
L	3.56	4.83
M	1.14	1.40
N	0.30	0.64
P	2.03	2.92
R	4.83	5.33
All Dimensions in mm		

### Maximum Ratings and Electrical Characteristics @ $T_A = 25^\circ\text{C}$ unless otherwise specified

Single phase, half wave, 60Hz, resistive or inductive load.  
For capacitive load, derate current by 20%.

Characteristic	Symbol	SBL 830	SBL 835	SBL 840	SBL 845	SBL 850	SBL 860	Unit
Peak Repetitive Reverse Voltage Working Peak Reverse Voltage DC Blocking Voltage	$V_{RRM}$ $V_{RWM}$ $V_R$	30	35	40	45	50	60	V
RMS Reverse Voltage	$V_{R(RMS)}$	21	24.5	28	31.5	35	42	V
Average Rectified Output Current (Note 1) @ $T_C = 95^\circ\text{C}$	$I_O$	8						A
Non-Repetitive Peak Forward Surge Current 8.3ms single half sine-wave superimposed on rated load (JEDEC Method)	$I_{FSM}$	200						A
Forward Voltage @ $I_F = 8\text{A}, T_C = 25^\circ\text{C}$	$V_{FM}$	0.55				0.70		V
Peak Reverse Current @ $T_C = 25^\circ\text{C}$ at Rated DC Blocking Voltage @ $T_C = 100^\circ\text{C}$	$I_{RM}$					0.5 50		mA
Typical Junction Capacitance (Note 2)	$C_j$	700						pF
Typical Thermal Resistance Junction to Case (Note 1)	$R_{\theta JC}$	6.9						$^\circ\text{C/W}$
Operating and Storage Temperature Range	$T_j, T_{STG}$	-65 to +150						$^\circ\text{C}$

- Notes: 1. Thermal resistance junction to case mounted on heatsink.  
2. Measured at 1.0MHz and Applied Reverse Voltage of 4.0V DC.



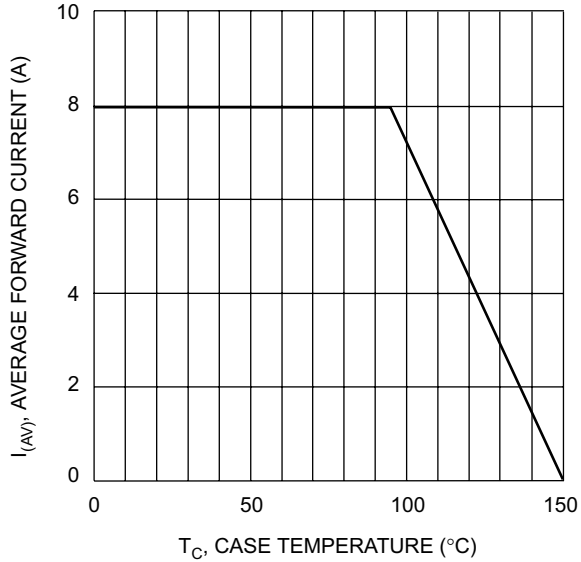

Fig. 1 Fwd Current Derating Curve

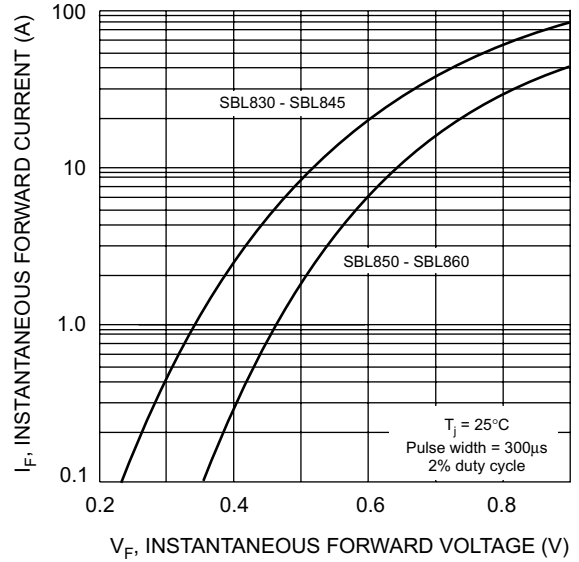

Fig. 2 Typical Forward Characteristics

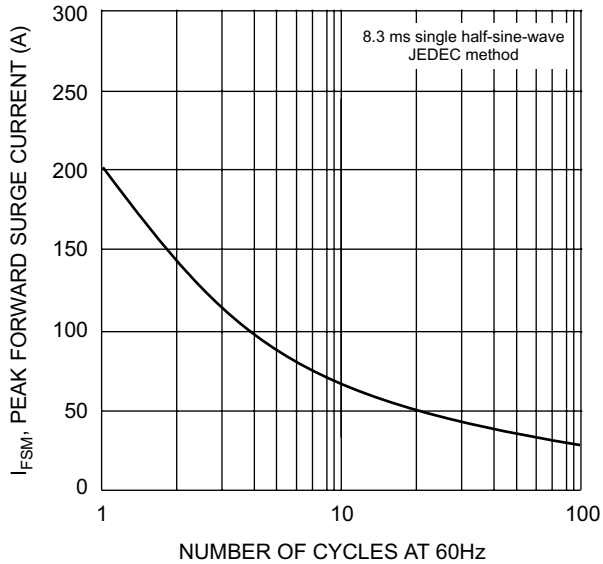

Fig. 3 Max Non-Repetitive Surge Current

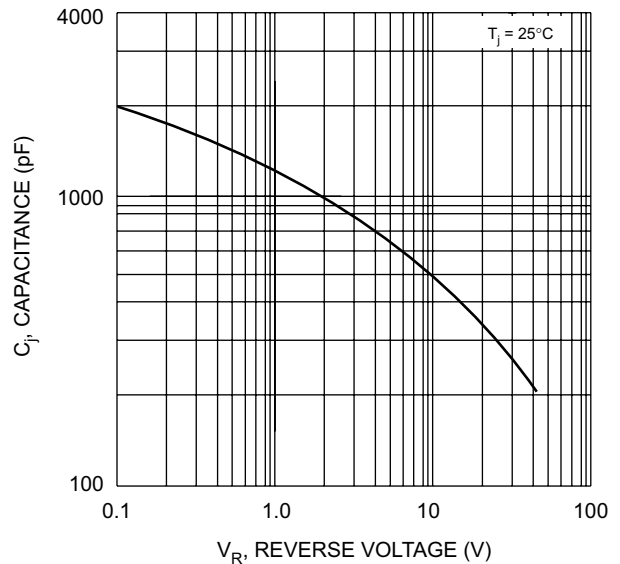

Fig. 4 Typical Junction Capacitance

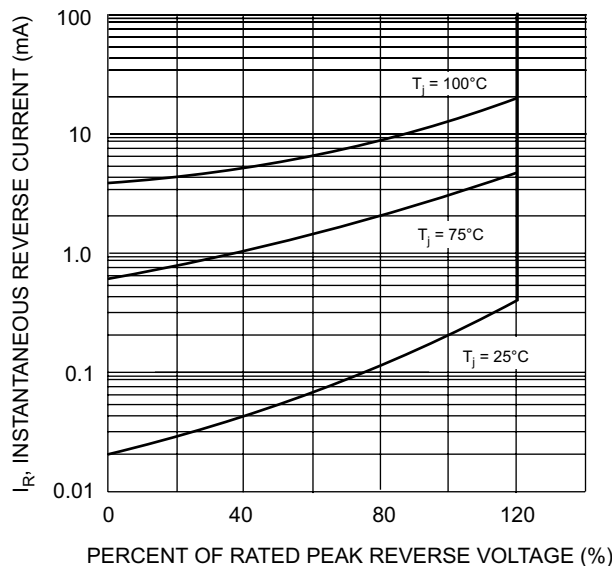

Fig. 5 Typical Reverse Characteristics