



PRECISION SHUNT VOLTAGE REFERENCE

SC1004(A)

May 1, 2000

TEL:805-498-2111 FAX:805-498-3804 WEB:http://www.semtech.com

DESCRIPTION

The SC1004(A) is a two terminal precision voltage reference with thermal stability guaranteed over temperature. The SC1004(A) has a typical dynamic output impedance of 0.2Ω. Active output circuitry provides a very sharp turn on characteristic - the minimum operating current is 20μA, with a maximum of 20mA.

Coming with an initial tolerance of ± 0.8% (0.32% for SC1004A), and with two available voltage options (1.235V and 2.5V) in a small SO-8 package, the SC1004(A) is ideally suited for very low power circuitry such as temperature sensors and portable meters.

FEATURES

- Trimmed bandgap design (0.8%, 0.32% for SC1004A version)
- Wide operating current range 20μA to 20mA
- Low dynamic impedance (0.2Ω)
- SO-8 package

APPLICATIONS

- Micropower circuitry
- Portable meters
- Battery powered systems
- Temperature sensors

BLOCK DIAGRAM

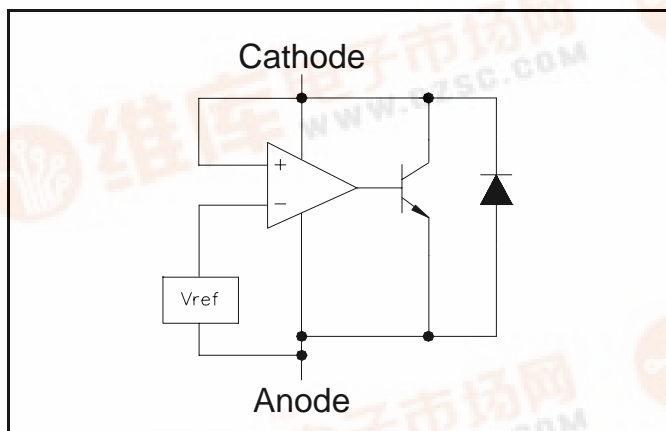

PIN CONFIGURATION

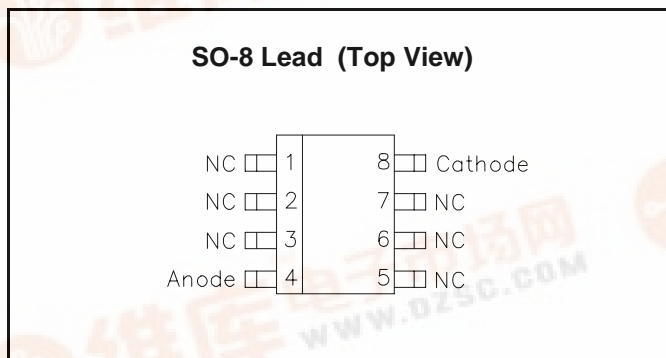

SYMBOL DIAGRAM

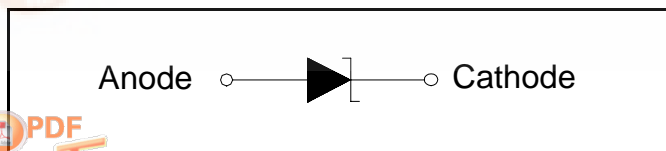

ORDERING INFORMATION

VOLTAGE ⁽¹⁾		INITIAL ACCURACY
1.235 V	2.5 V	
SC1004CS8-1.2.TR	SC1004CS8-2.5.TR	±0.8%
SC1004ACS8-1.2.TR	-	±0.32%

Notes:

(1) Only available in tape and reel packaging. A reel contains 2500 devices.

ABSOLUTE MAXIMUM RATINGS

Parameter	Symbol	Maximum	Units
Reverse Current		20	mA
Operating Temperature Range	T _A	-40 to +85	°C
Operating Junction Temperature Range	T _J	-40 to +150	°C
Storage Temperature Range	T _{STG}	-65 to +150	°C
Lead Temperature (Soldering) 10 seconds	T _{LEAD}	300	°C



May 1, 2000

ELECTRICAL CHARACTERISTICS

T _A = 25°C unless otherwise specified.				-1.2			-2.5			
Parameter	Symbol	Condition		MIN	TYP	MAX	MIN	TYP	MAX	UNITS
Reverse Breakdown Voltage, SC1004	V _Z	I _Z = 100μA	T _A = 25°C	1.225	1.235	1.245	2.480	2.500	2.520	V
			T _A = 0 to +70°C	1.220	1.235	1.250	2.470	2.500	2.530	
			T _A = -40 to +85°C	1.215	1.235	1.255	2.460	2.500	2.535	
Reverse Breakdown Voltage, SC1004A	V _Z	I _Z = 100μA	T _A = 25°C	1.231	1.235	1.239	N/A	N/A	N/A	V
			T _A = 0 to +70°C	1.225	1.235	1.245	N/A	N/A	N/A	
			T _A = -40 to +85°C	1.220	1.235	1.245	N/A	N/A	N/A	
Average Temperature Coefficient	$\frac{\Delta V_Z}{\Delta T}$	I _{Z(min)} ≤ I _Z ≤ 20mA			20			20		ppm/°C
Minimum Operating Current	I _{Z(min)}		T _A = -40 to +85°C		8	10		12	20	μA
Ratio of Change in V _Z to Change in I _Z	$\frac{\Delta V_Z}{\Delta I_Z}$	I _{Z(min)} ≤ I _Z ≤ 1mA	T _A = 25°C			1.0			1.0	mV
			T _A = -40 to +85°C			1.5		1.5		
		1mA ≤ I _Z ≤ 20mA	T _A = 25°C			10		10		
			T _A = -40 to +85°C			20		20		
Reverse Dynamic Impedance	Z _R	I _Z = 100μA	T _A = 25°C		0.2	0.6		0.2	0.6	Ω
			T _A = -40 to +85°C			1.5		1.5		
Wideband Noise (RMS)	e _N	I _Z = 100μA, 10Hz ≤ f ≤ 10kHz			60			120		μV
Long Term Stability of Reverse Break-down Voltage	ΔV _Z	t = 1000 hours, T = 25°C ± 0.1°C, I _Z = 100μA			20			20		ppm

May 1, 2000

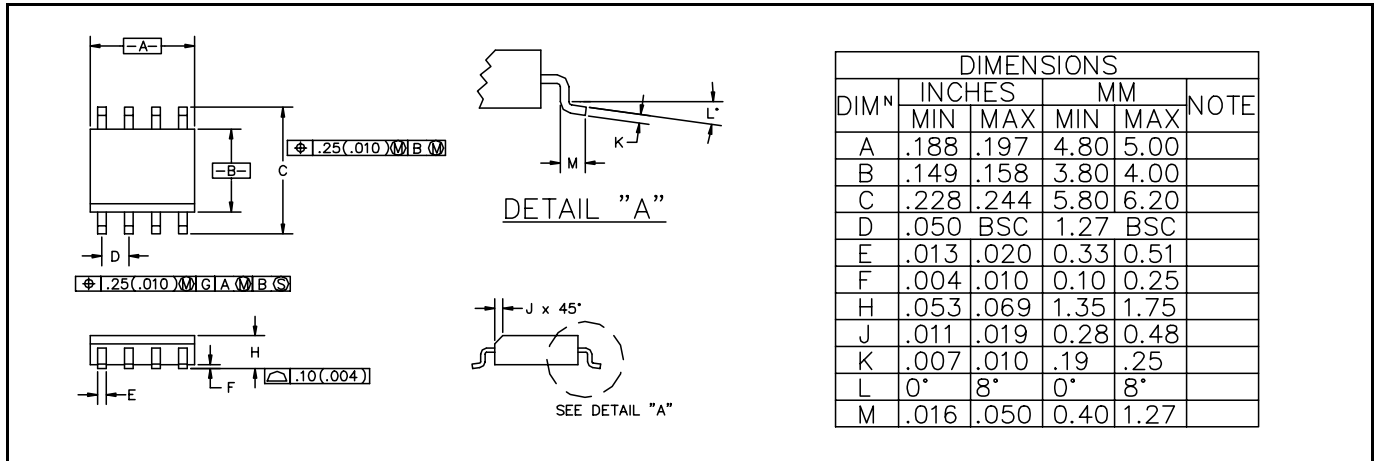
OUTLINE DRAWING - SO-8

LAND PATTERN - SO-8
