

PRECISION SINGLE CELL TIMER

ZSCT1555

ISSUE 2 - MAY 1998

DEVICE DESCRIPTION

These devices are precision timing circuits for generation of accurate time delays or oscillation. Advanced circuit design means that these devices can operate from a single battery cell with the minimum of quiescent current.

In monostable mode time delays are controlled by a single resistor and capacitor network. In astable mode the frequency and duty cycle can be accurately and independently controlled with two external resistors and one capacitor.

The threshold and trigger levels are normally set as a proportion of V_{CC} by internal resistors. These levels can be programmed by the use of the control input pin.

When the trigger input reduces to a value below the trigger level, the flip-flop is set and the output goes high. With the trigger input above the trigger level and the threshold input above the threshold level, the flip-flop is reset

and the output goes low. The reset pin has priority over all the other inputs and is used to start new timing cycles. A low on the reset input causes the flip-flop to reset forcing the output low. Whenever the output is forced low then the internal discharge transistor is turned on.

FEATURES

- 0.9V supply operating voltage guaranteed
- Pin connections comparable with 555 series timers
- Very low quiescent current 74 μA
- SO8 and DIL8 packages
- Operating temperature range compatible with battery technologies

APPLICATIONS

- Portable and battery powered equipment
- Low voltage and low power systems

SCHEMATIC DIAGRAM

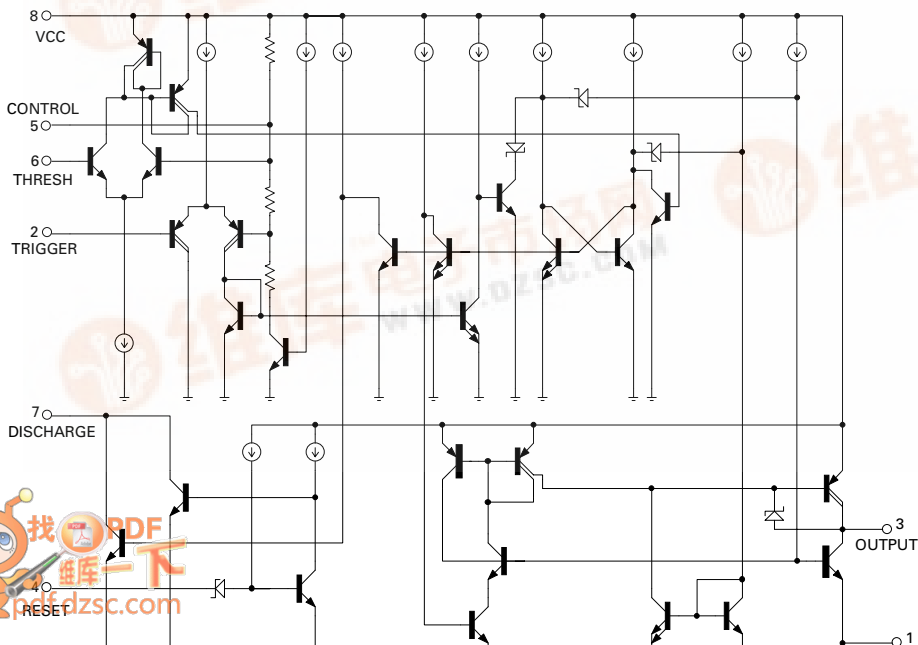

ZSCT1555

ABSOLUTE MAXIMUM RATINGS

Supply Voltage	9V
Input Voltages (Cont, Reset, Thres, Trig)	9V
Output Current	100mA
Operating Temperature	-20 to 100°C
Storage Temperature	-55 to 150°C

Power Dissipation (T_{amb}=25°C)	
DIL8	625mW
SO8	625mW

Recommended Operating Conditions

Supply Voltage	0.9V(min)	6V(max)
Input Voltages (Cont, Reset, Thres, Trig)	6V(max)	
Output Current	Sink	100mA(max)
	Source	150µA(max)

ELECTRICAL CHARACTERISTICS

TEST CONDITIONS (Unless otherwise stated): T_{amb} = 25°C, V_{CC} = 1.5V

SYMBOL	PARAMETER	CONDITIONS	LIMITS			UNITS
			MIN.	TYP.	MAX.	
V _{CC}	Supply Voltage		0.9		6	V
I _{CC}	Supply Current	no load V _{CC} = 5V, no load		74 150	120 200	mA
V _{TH}	Threshold Voltage	V _{CC} = 5V	1.195 3.9	1.22 4	1.245 4.1	V
I _{TH}	Threshold Current (Note 1)		0	20	100	nA
V _{TR}	Trigger Voltage	V _{CC} = 5V	0.2 0.57	0.25 0.62	0.3 0.67	V
I _{TR}	Trigger Current		0	-35	-100	nA
t _{PD}	Trigger Propagation delay	Delay from trigger to output		2		µs
V _{RS}	Reset Voltage		0.1	0.2	0.4	V
I _{RS}	Reset Current	Reset @ 0V	0	-5	-10	µA
I _{DS}	Discharge switch Off-state current		0	10	100	nA
V _{DS}	Discharge switch On-state voltage	I _{DS} = 0.2mA V _{CC} = 5V, I _{DS} = 0.3mA	0 0	180 240	225 350	mV
V _{CT}	Control Voltage (Open Circuit)	V _{CC} = 5V	1.195 3.9	1.22 4	1.245 4.1	V
V _{OL}	Output Voltage (Low)	I _{OL} =10mA I _{OL} =50mA V _{CC} =5V, I _{OL} =10mA V _{CC} =5V, I _{OL} =100mA	0 0 0 0	0.15 0.45 0.13 0.65	0.3 0.65 0.3 1	V
V _{OH}	Output Voltage (High)	I _{OH} = 100µA V _{CC} = 5V, I _{OH} = 150µA	1 4.5	1.1 4.6	1.5 5	V

ZSCT1555

ELECTRICAL CHARACTERISTICS (Continued)

TEST CONDITIONS (Unless otherwise stated): $T_{amb}=25^{\circ}\text{C}$, $V_{CC}=1.5\text{V}$

SYMBOL	PARAMETER	CONDITIONS	LIMITS			UNITS
			MIN.	TYP.	MAX.	
t_R	Output pulse rise time	$C_L=10\text{pF}$ $V_{CC}=5\text{V}$, $C_L=10\text{pF}$		1.6 1.2		μs
t_F	Output pulse fall time	$C_L=10\text{pF}$ $V_{CC}=5\text{V}$, $C_L=10\text{pF}$		240 24		ns
$\Delta t_{IA(m)}$	Timing error, Monostable Initial accuracy (Note 2)	$RA=10$ to $50\text{ k}\Omega$		1.6		%
$\Delta t_{V(m)}$	Drift with supply voltage	$RB=10$ to $50\text{ k}\Omega$		0.262		%/V
$\Delta t_{T(m)}$	Drift with temperature	$C_T=68\text{nF}$		100		ppm/ $^{\circ}\text{C}$
$\Delta t_{IA(a)}$	Timing error, Astable Initial accuracy (Note 2)	$RA=10$ to $50\text{ k}\Omega$		4.8		%
$\Delta t_{V(a)}$	Drift with supply voltage	$RB=10$ to $50\text{ k}\Omega$		0.662		%/V
$\Delta t_{T(a)}$	Drift with temperature	$C_T=68\text{nF}$		150		ppm/ $^{\circ}\text{C}$
f_A	Astable maximum frequency	$RA=20\text{ k}\Omega$ $RB=10\text{ k}\Omega$ $C_T=47\text{pF}$			330	kHz

Note 1: This will influence the maximum values of RA and RB ($RA_{MAX}=10\text{M}\Omega$, $RB_{MAX}=1.5\text{M}\Omega$)

Note 2: Is defined as the difference between the measured value and the average value of a random sample taken on a batch basis

ZSCT1555

TYPICAL CHARACTERISTICS

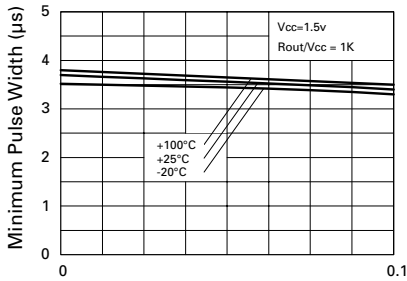

Lowest Voltage Level of Trigger Pulse ($\times V_{CC}$)
Minimum Pulse Width Required for Triggering

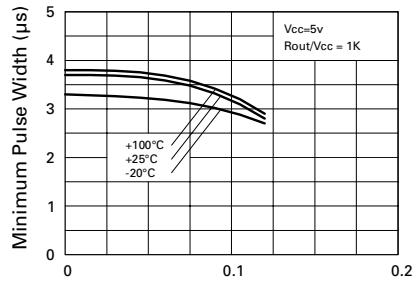

Lowest Voltage Level of Trigger Pulse ($\times V_{CC}$)
Minimum Pulse Width Required for Triggering

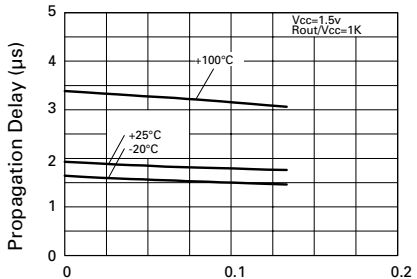

Lowest Voltage Level of Trigger Pulse ($\times V_{CC}$)
Output Propagation Delay

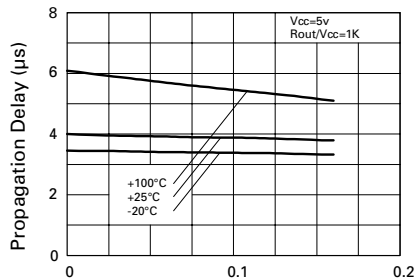

Lowest Voltage Level of Trigger Pulse ($\times V_{CC}$)
Output Propagation Delay

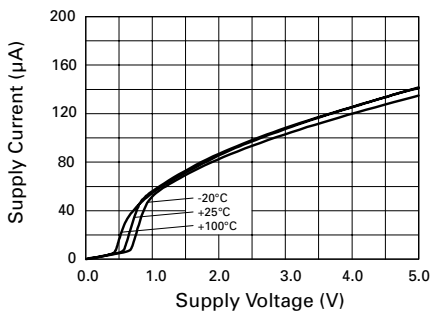

Supply Current v Supply Voltage

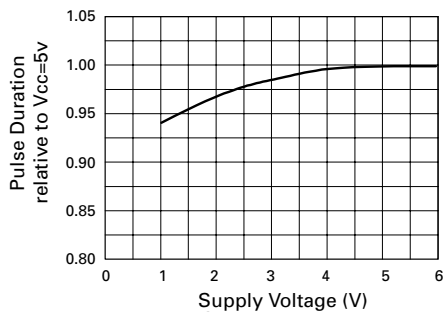

Normalized Output Pulse Duration v Supply Voltage

ZSCT1555

TYPICAL CHARACTERISTICS

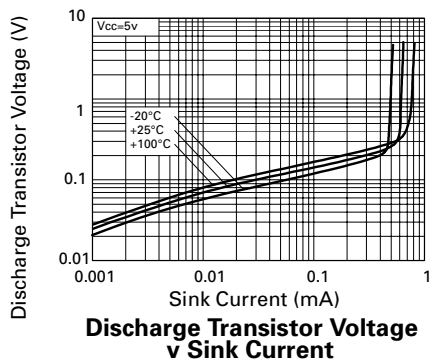
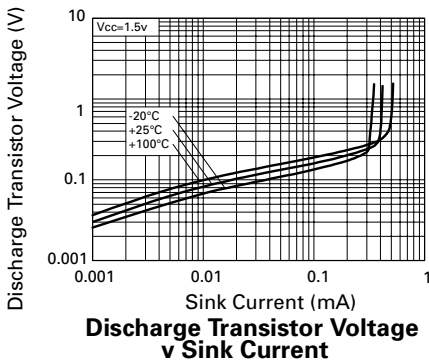
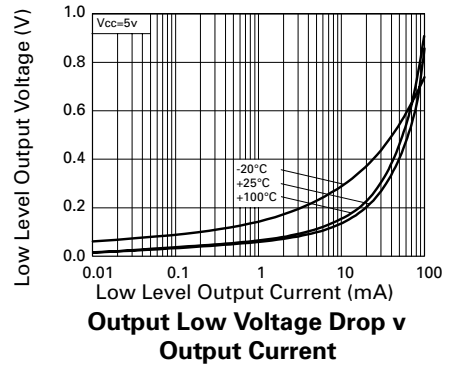
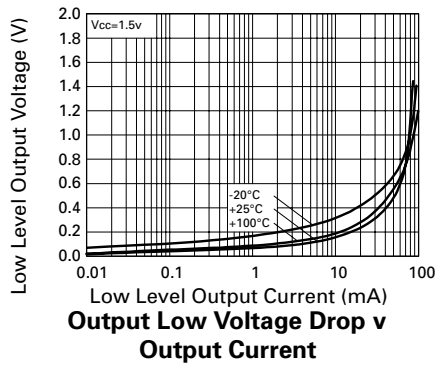
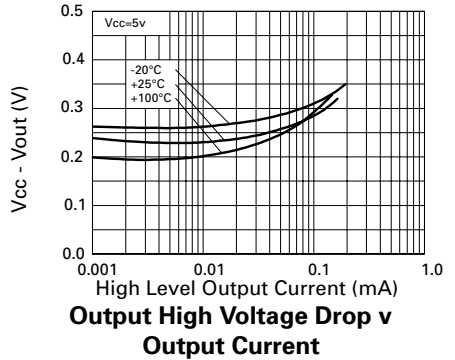
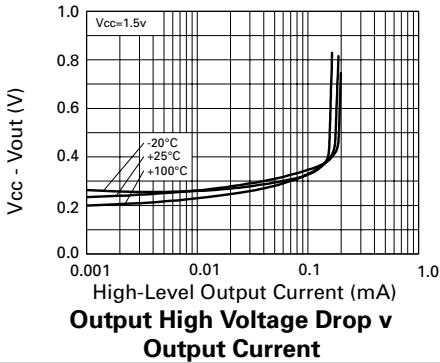

ZSCT1555

FUNCTIONAL DIAGRAM

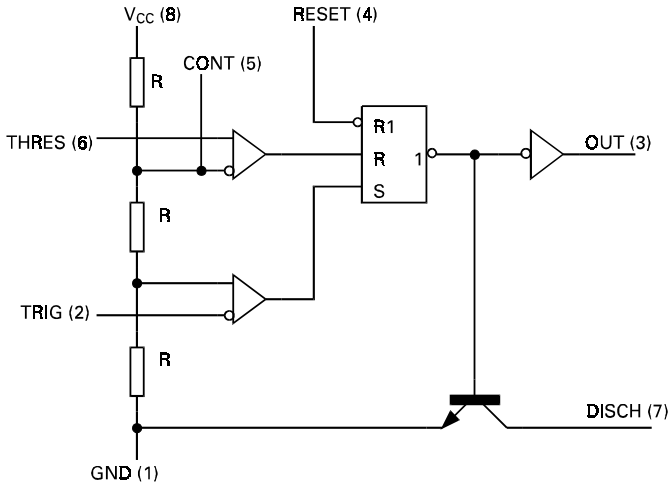

FUNCTIONAL TABLE

RESET	TRIGGER VALUE	THRESHOLD VOLTAGE	OUTPUT	DISCHARGE SWITCH
Low	N/A	N/A	Low	On
High	$<V_{CC}/5$	N/A	High	Off
High	$>V_{CC}/5$	$>4V_{CC}/5$	Low	On
High	$>V_{CC}/5$	$<4V_{CC}/5$	As Previously established	

POWER DERATING TABLE

Package	$T_A \leq 25^\circ\text{C}$ Power Rating	Derating Factor Above $T_A = 25^\circ\text{C}$	$T_A = 70^\circ\text{C}$ Power Rating	$T_A = 85^\circ\text{C}$ Power Rating
N8	625mW	6.25mW/ $^\circ\text{C}$	330mW	250mW
D8	625mW	6.25mW/ $^\circ\text{C}$	330mW	250mW

ZSCT1555

APPLICATIONS INFORMATION

Many configurations of the ZSCT1555 are possible. The following gives a selection of a few of these using the most basic monostable and astable connections. The final application example in astable mode shows the device optimum use for low voltage and power economy in a single cell boost converter.

Monostable Operation

Figure 1 shows connection of the timer as a one-shot whose pulse period is independent of supply voltage. Initially the capacitor is held discharged. The application of a negative going trigger pulse sets an internal flip flop which allows the capacitor to start to charge up via RA and forces the output high. The voltage on the capacitor increases for time t , where $t = 1.63RAC_T$, at the end of this period the voltage on the capacitor is $0.8 V_{CC}$. At this point the flip flop resets, the capacitor is discharged and the output is driven low.

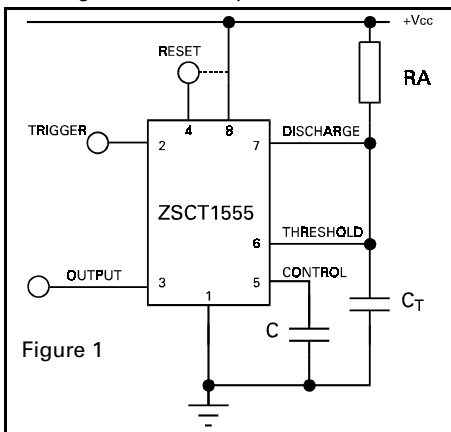

Figure 1

Figure 2 shows the timing diagram for this function. During the output high period further trigger pulses are locked out however the circuit can be reset by application of a negative going pulse on the reset pin. Once the output is driven low it remains in this state until the application of the next trigger pulse. If the reset function is not used then it is recommended to connect to V_{CC} to eliminate

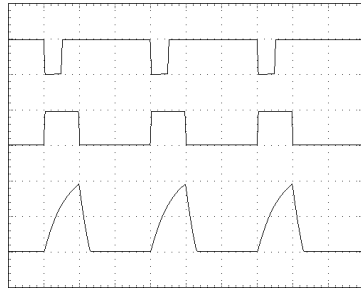

Figure 2

Figure 3 gives an easy selection of R_A and C_T values for various time delays.

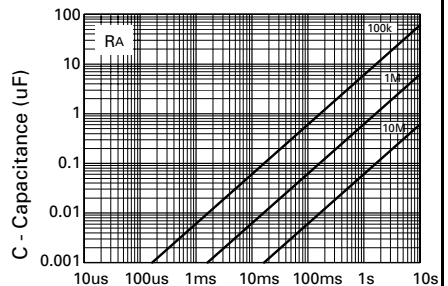

Figure 3

Time Delay

This configuration of circuit can be used as a frequency divider by adjusting the timing period. Figure 4 indicates a divide by three.

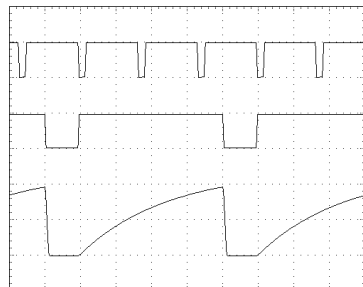

Figure 4

ZSCT1555

Figure 5 shows the monostable mode used as a pulse width modulator. Here the trigger pin is supplied with a continuous pulse train, the resulting output pulse width is modulated by a signal applied to the control pin.

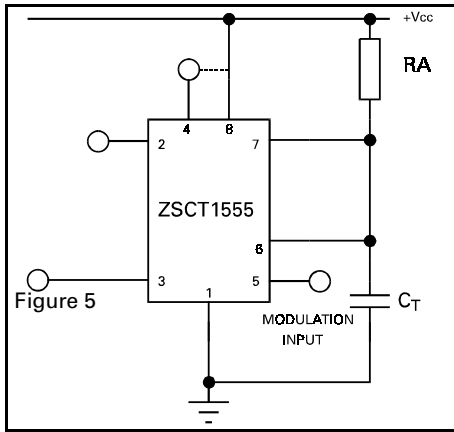

Figure 6 shows typical waveform examples.

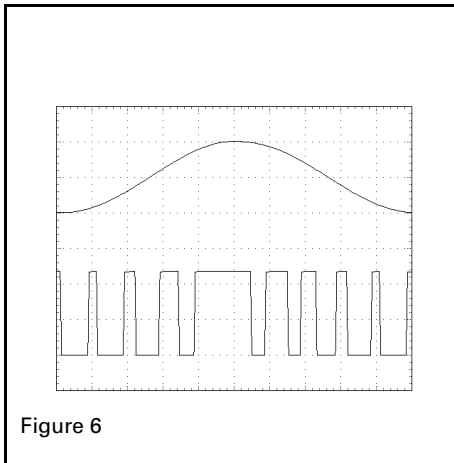

Figure 6

Astable operation

The configuration of Figure 7 produces a free running multivibrator circuit whose frequency is independent of supply voltage. The ratio of resistors RA and RB precisely sets the circuit duty cycle. The capacitor is charged and discharged between thresholds at $0.2V_{CC}$ and $0.8V_{CC}$. Oscillation frequency (f) and duty cycle (d) can be calculated using the following equations:-

$$f = 0.62 / (RA + 2RB) C_T$$

$$d = RB / (RA + 2RB)$$

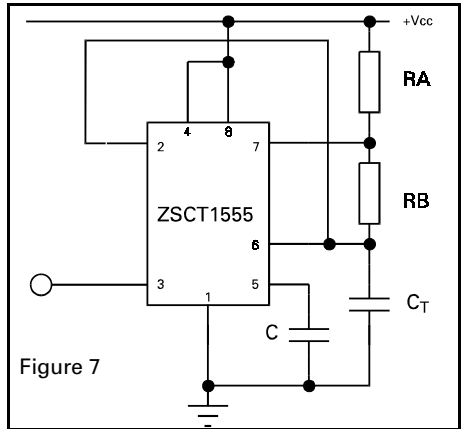

Figure 7

Figure 8 shows the waveforms generated in this mode of operation.

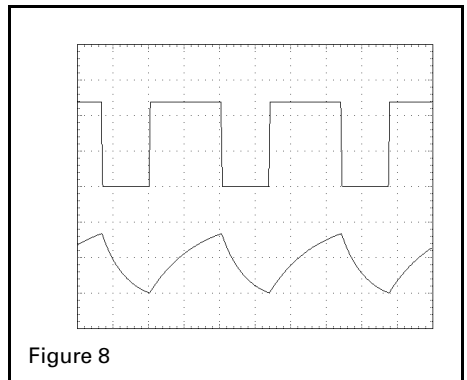

Figure 8

ZSCT1555

Figure 9 gives an easy selection for RA, RB and CT values.

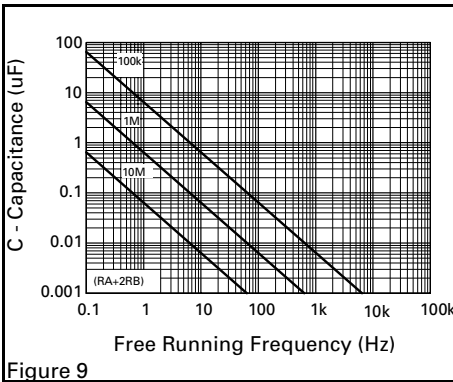
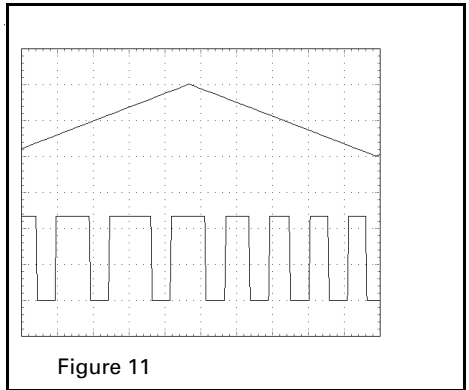
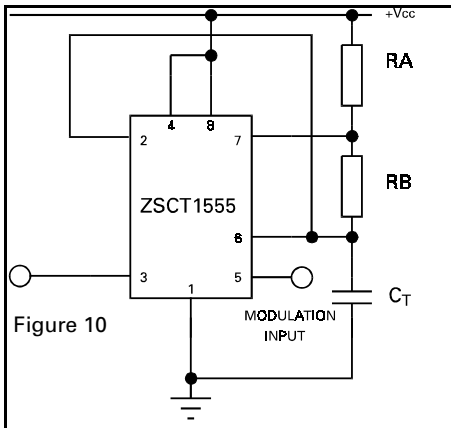

Figure 11 shows the result of modulation with a triangle wave input to the control pin.



Similar to the PWM circuit of Figure 5 the astable circuit can be configured with modulation of the control input as shown in Figure 10. The result is a pulse position modulated, PPM, circuit where the pulse position is altered by the control input voltage.



ZSCT1555

The circuit of Figure 12 shows the device in astable mode operating as part of a single cell boost converter. This circuit generates a 5 volt supply from a single battery cell. The circuit output voltage is maintained down to 0.9 volts input and power economy is optimised for extended battery life.

CONNECTION DIAGRAM

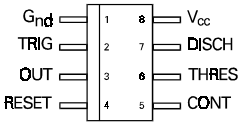

ORDERING INFORMATION

Part Number	Package	Part Mark
ZSCT1555D8	DIL8	ZSCT1555
ZSCT1555N8	SO8	ZSCT1555

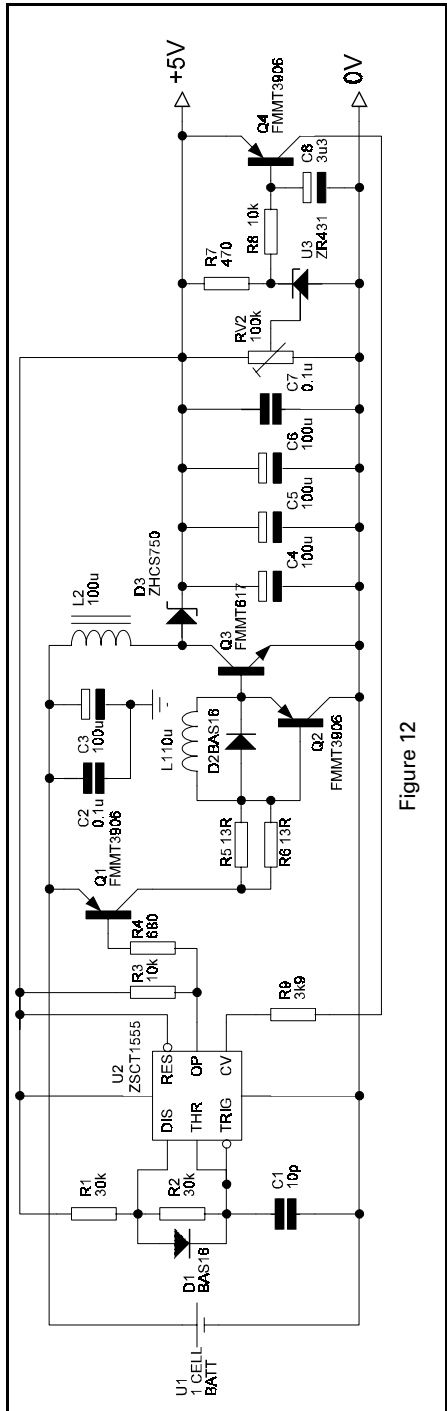

Figure 12