



SD103ASDM

SURFACE MOUNT SCHOTTKY BARRIER DIODE ARRAY

NEW PRODUCT

Features

- Low Forward Voltage Drop
- Guard Ring Construction for Transient Protection
- Fast Switching
- Low Reverse Capacitance

Mechanical Data

- Case: SOT-26, Plastic
- Case material - UL Flammability Rating Classification 94V-0
- Moisture sensitivity: Level 1 per J-STD-020A
- Polarity: See Diagram
- Leads: Solderable per MIL-STD-202, Method 208
- Marking: KSU (See Page 2)
- Weight: 0.016 grams (approx.)

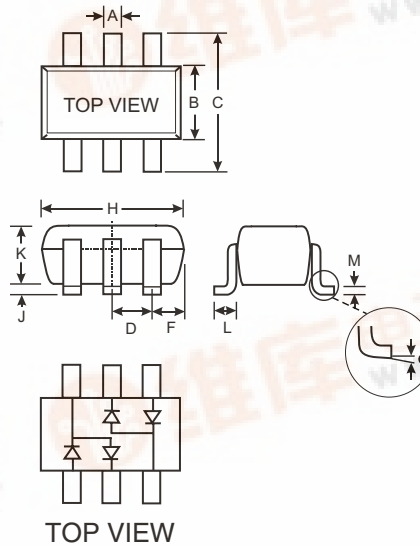

SOT-26			
Dim	Min	Max	Typ
A	0.35	0.50	0.38
B	1.50	1.70	1.60
C	2.70	3.00	2.80
D	—	—	0.95
F	—	—	0.55
H	2.90	3.10	3.00
J	0.013	0.10	0.05
K	1.00	1.30	1.10
L	0.35	0.55	0.40
M	0.10	0.20	0.15
α	0°	8°	—
All Dimensions in mm			

Maximum Ratings @ $T_A = 25^\circ\text{C}$ unless otherwise specified

Characteristic	Symbol	Value	Unit
Peak Repetitive Reverse Voltage Working Peak Reverse Voltage DC Blocking Voltage	V_{RRM} V_{RWM} V_R	40	V
RMS Reverse Voltage	$V_{R(RMS)}$	28	V
Forward Continuous Current (Note 1)	I_{FM}	350	mA
Non-Repetitive Peak Forward Surge Current @ $t \leq 1.0\text{s}$	I_{FSM}	1.5	A
Power Dissipation (Note 1)	P_d	225	mW
Thermal Resistance, Junction to Ambient Air (Note 1)	$R_{\theta JA}$	444	$^\circ\text{C}/\text{W}$
Operating and Storage Temperature Range	T_j, T_{STG}	-65 to +125	$^\circ\text{C}$

Electrical Characteristics @ $T_A = 25^\circ\text{C}$ unless otherwise specified

Characteristic	Symbol	Min	Typ	Max	Unit	Test Condition
Reverse Breakdown Voltage (Note 2)	$V_{(BR)R}$	40	—	—	V	$I_R = 100\mu\text{A}$
Forward Voltage Drop (Note 2)	V_F	—	—	0.37 0.50 0.60	V	$I_F = 20\text{mA}$ $I_F = 100\text{mA}$ $I_F = 200\text{mA}$
Reverse Current (Note 2)	I_R	—	—	5.0	μA	$V_R = 30\text{V}$
Total Capacitance	C_T	—	50	—	pF	$V_R = 0\text{V}, f = 1.0\text{MHz}$
Reverse Recovery Time	t_{rr}	—	10	—	ns	$I_F = I_R = 200\text{mA}$, $t_{rr} = 0.1 \times I_R, R_L = 100\Omega$

- Notes: 1. Device mounted on FR-5 PCB 1.0 x 0.75 x 0.062 inch pad layout as shown on Diodes Inc. suggested pad layout AP02001, which can be found on our website at <http://www.diodes.com/datasheets/ap02001.pdf>.
2. Short duration test pulse used to minimize self-heating effect.



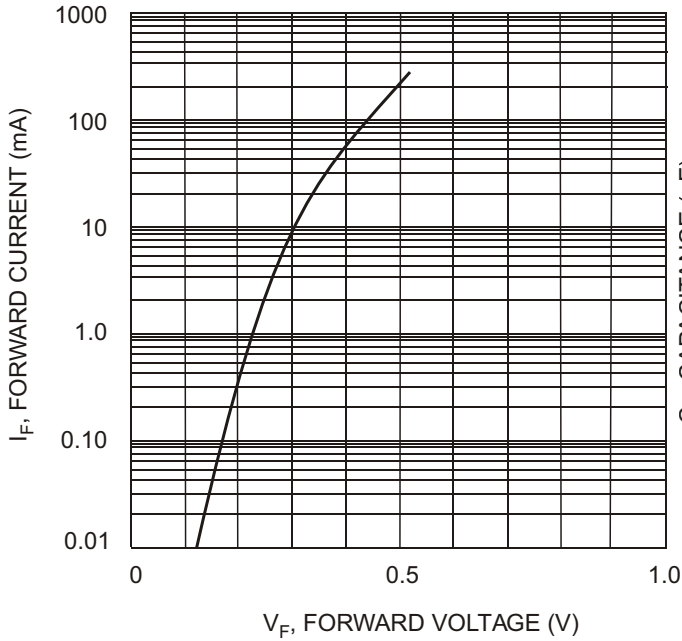

Fig. 1 Typical Forward Characteristics

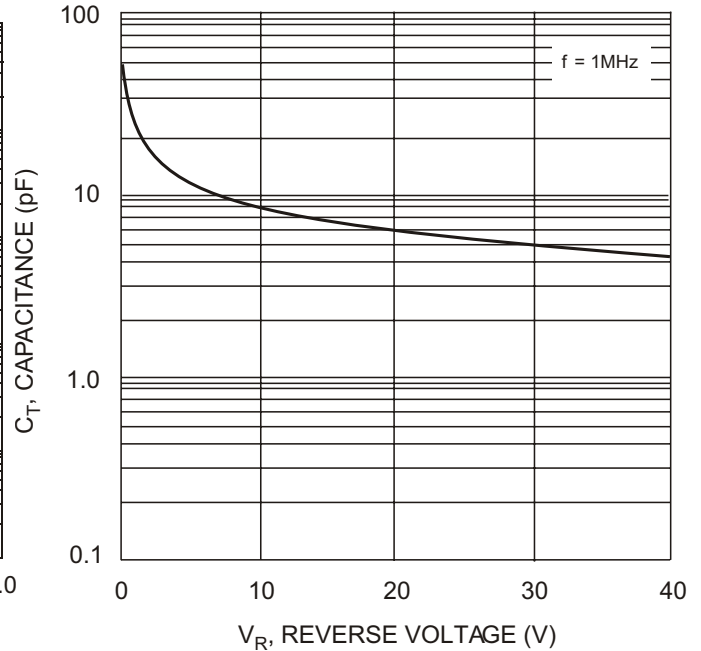

Fig. 2 Typical Total Capacitance vs Reverse Voltage

Ordering Information (Note 3)

Device	Packaging	Shipping
SD103ASDM-7	SOT-26	3000/Tape & Reel

Notes: 3. For Packaging Details, go to our website at <http://www.diodes.com/datasheets/ap02007.pdf>.

Marking Information

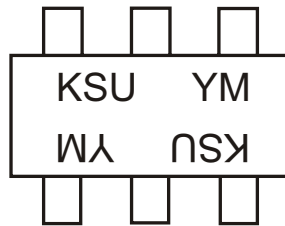

KSU = Product Type Marking Code
 YM = Date Code Marking
 Y = Year ex: N = 2002
 M = Month ex: 9 = September

Date Code Key

Year	2002	2003	2004	2005	2006	2007	2008	2009
Code	N	P	R	S	T	U	V	W

Month	Jan	Feb	March	Apr	May	Jun	Jul	Aug	Sep	Oct	Nov	Dec
Code	1	2	3	4	5	6	7	8	9	O	N	D