

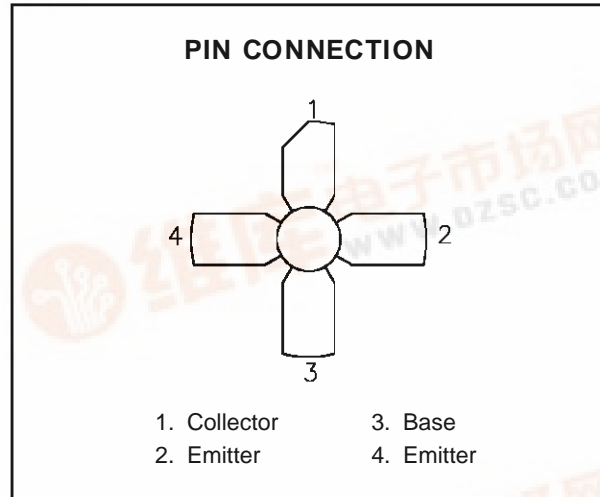

**SD1134**

**RF & MICROWAVE TRANSISTORS  
UHF MOBILE APPLICATIONS**

- 450 - 512 MHz
- 12.5 VOLTS
- EFFICIENCY 55%
- COMMON EMITTER
- P<sub>OUT</sub> = 2.0 W MIN. WITH 10.0 dB GAIN

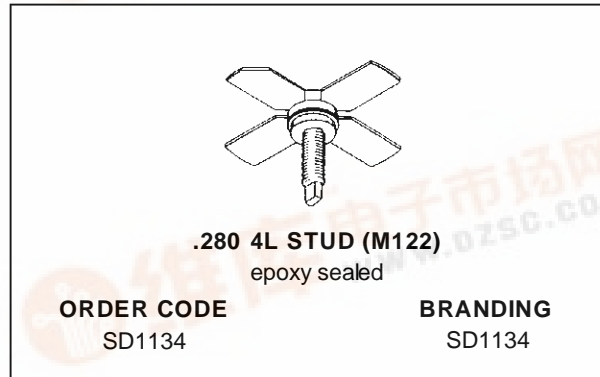

**DESCRIPTION**

The SD1134 is a 12.5 V Class C epitaxial silicon NPN planar transistor designed primarily for UHF communications. This device utilizes improved metallization to achieve infinite VSWR at rated operating conditions.

**ABSOLUTE MAXIMUM RATINGS (T<sub>case</sub> = 25°C)**

Symbol	Parameter	Value	Unit
V <sub>CBO</sub>	Collector-Base Voltage	36	V
V <sub>CEO</sub>	Collector-Emitter Voltage	16	V
V <sub>CES</sub>	Collector-Emitter Voltage	36	V
V <sub>EBO</sub>	Emitter-Base Voltage	4.0	V
I <sub>c</sub>	Device Current	0.75	A
P <sub>DISS</sub>	Power Dissipation	5	W
T <sub>J</sub>	Junction Temperature	+200	°C
T <sub>STG</sub>	Storage Temperature	- 65 to +150	°C

**THERMAL DATA**

R <sub>TH(j-c)</sub>	Junction-Case Thermal Resistance	35	°C/W
----------------------	----------------------------------	----	------



# SD1134

## ELECTRICAL SPECIFICATIONS (T<sub>case</sub> = 25°C)

### STATIC

Symbol	Test Conditions		Value			Unit
			Min.	Typ.	Max.	
BV <sub>CES</sub>	I <sub>C</sub> = 5mA	V <sub>BE</sub> = 0V	36	—	—	V
BV <sub>CEO</sub>	I <sub>C</sub> = 25mA	I <sub>B</sub> = 0mA	16	—	—	V
BV <sub>EBO</sub>	I <sub>E</sub> = 1mA	I <sub>C</sub> = 0mA	4.0	—	—	V
I <sub>CBO</sub>	V <sub>CB</sub> = 15V	I <sub>E</sub> = 0mA	—	—	1	mA
h <sub>FE</sub>	V <sub>CE</sub> = 5V	I <sub>C</sub> = 100mA	20	—	—	—

### DYNAMIC

Symbol	Test Conditions			Value			Unit
				Min.	Typ.	Max.	
P <sub>OUT</sub>	f = 470 MHz	P <sub>IN</sub> = 0.20 W	V <sub>CC</sub> = 12.5 V	2.0	—	—	W
G <sub>P</sub>	f = 470 MHz	P <sub>IN</sub> = 0.20 W	V <sub>CC</sub> = 12.5 V	10.0	—	—	dB
C <sub>OB</sub>	f = 1 MHz	V <sub>CB</sub> = 12 V		—	6	—	pF

### TYPICAL PERFORMANCE

**POWER OUTPUT & COLLECTOR EFFICIENCY vs POWER INPUT**

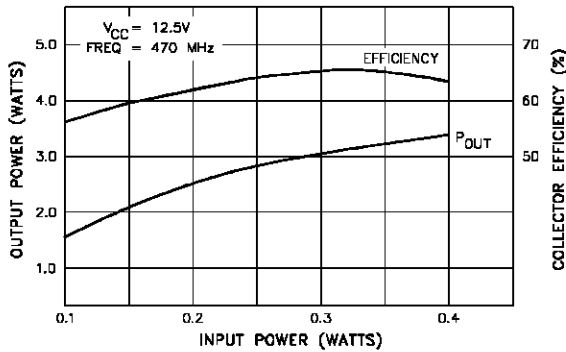

**POWER OUTPUT vs FREQUENCY**

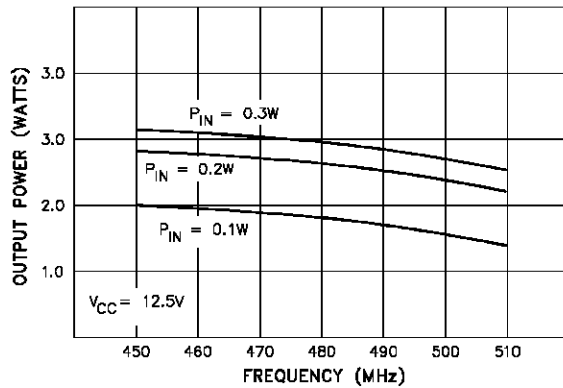

**CAPACITANCE vs VOLTAGE**

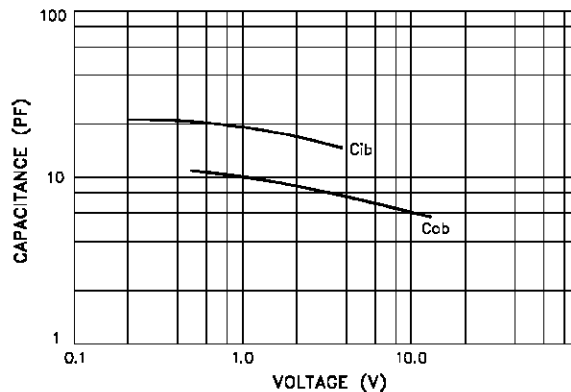

## IMPEDANCE DATA

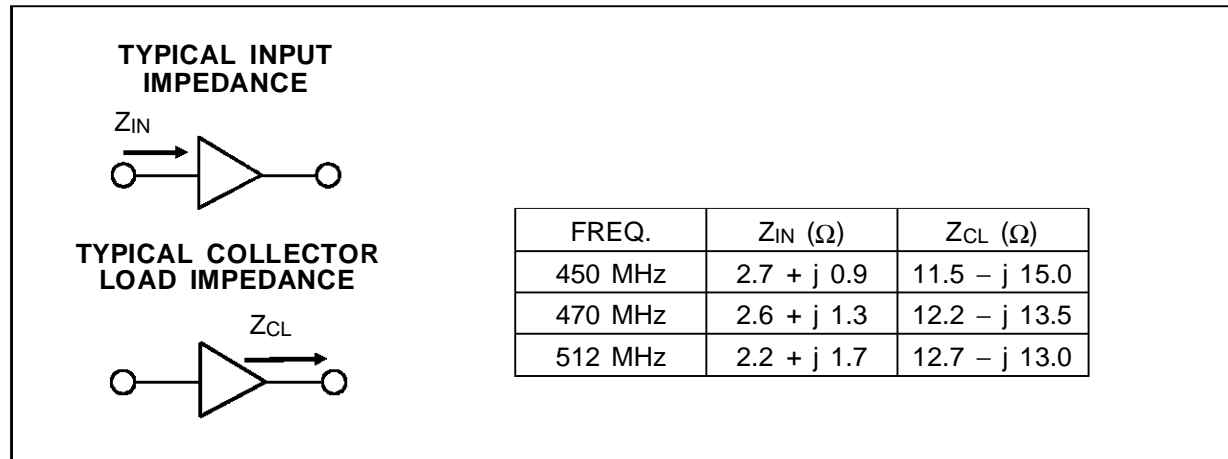

## TEST CIRCUIT

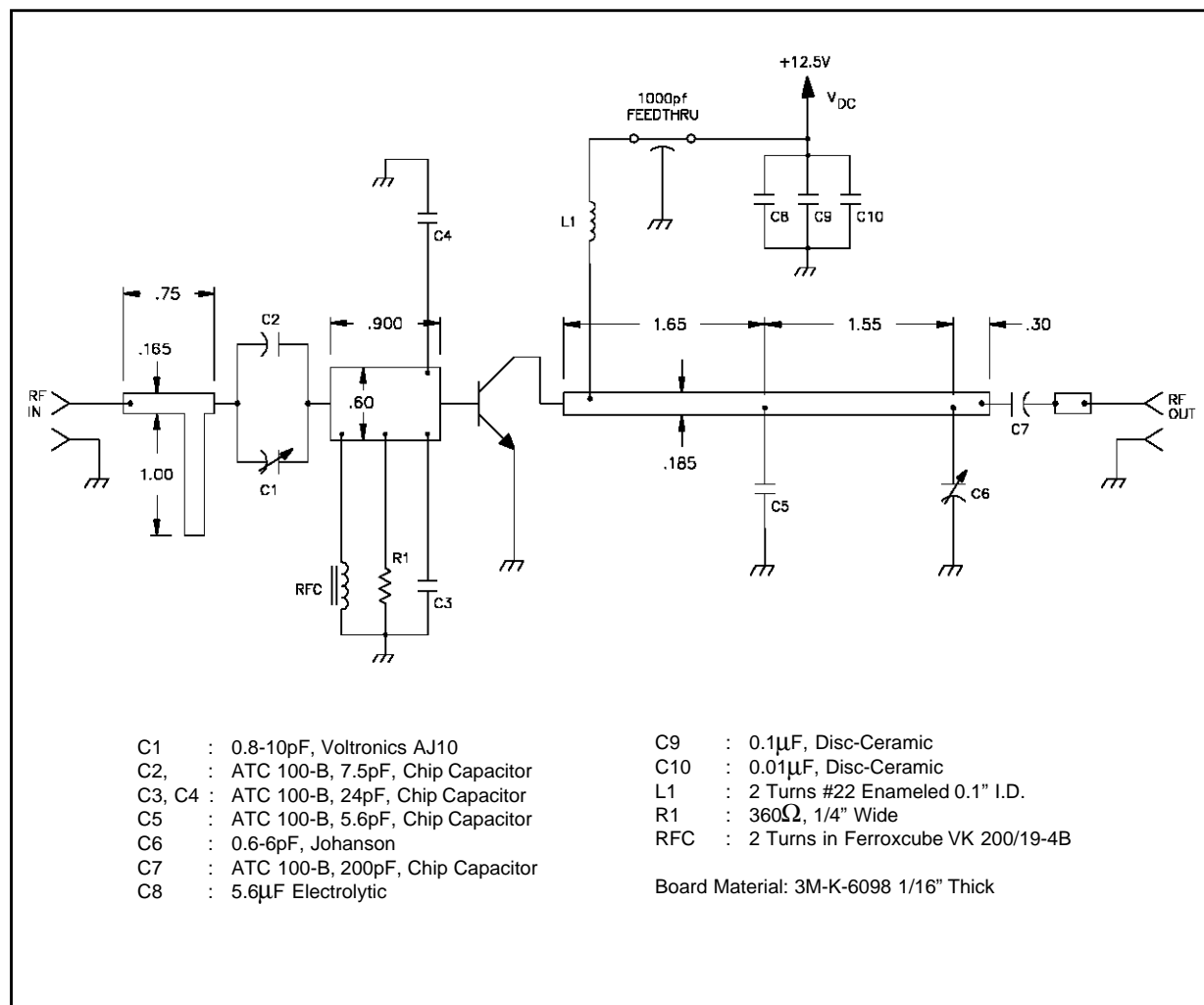

# SD1134

## PACKAGE MECHANICAL DATA

Ref.: Dwg. No.12-0122

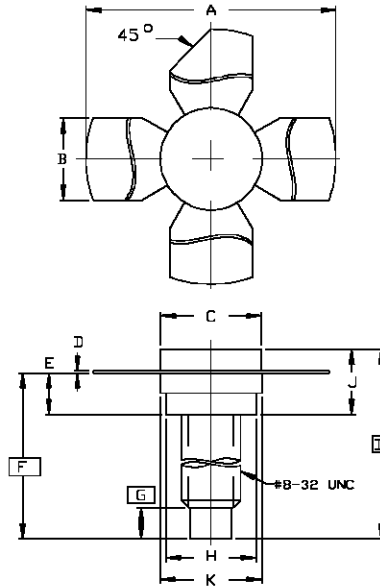

SGS-THOMSON MICROELECTRONICS		
	MINIMUM Inches/mm	MAXIMUM Inches/mm
A	1.010/25,65	1.055/26,80
B	.220/5,59	.230/5,84
C	.270/6,86	.285/7,24
D	.003/0,08	.007/0,18
E	.117/2,97	.137/3,48
F	.572/14,53	
G	.130/3,30	
H	.245/6,22	.255/6,48
I	.640/16,26	
J	.175/4,45	.217/5,51
K	.275/6,99	.285/7,24

Information furnished is believed to be accurate and reliable. However, SGS-THOMSON Microelectronics assumes no responsibility for the consequences of use of such information nor for any infringement of patents or other rights of third parties which may result from its use. No license is granted by implication or otherwise under any patent or patent rights of SGS-THOMSON Microelectronics. Specifications mentioned in this publication are subject to change without notice. This publication supersedes and replaces all information previously supplied. SGS-THOMSON Microelectronics products are not authorized for use as critical components in life support devices or systems without express written approval of SGS-THOMSON Microelectronics.

© 1994 SGS-THOMSON Microelectronics - All Rights Reserved

SGS-THOMSON Microelectronics GROUP OF COMPANIES  
 Australia - Brazil - France - Germany - Hong Kong - Italy - Japan - Korea - Malaysia - Malta - Morocco - The Netherlands -  
 Singapore - Spain - Sweden - Switzerland - Taiwan - Thailand - United Kingdom - U.S.A