



SD2922

RF POWER TRANSISTORS HF/VHF/UHF N-CHANNEL MOSFETs

- GOLD METALLIZATION
- EXCELLENT THERMAL STABILITY
- COMMON SOURCE CONFIGURATION
- POUT = 300W MIN. WITH 12.5 dB GAIN @175 MHz

DESCRIPTION

The SD2922 is a gold metallized N-Channel MOS field-effect RF power transistor. The SD2922 is intended for use in 50V dc large signal applications up to 200 MHz

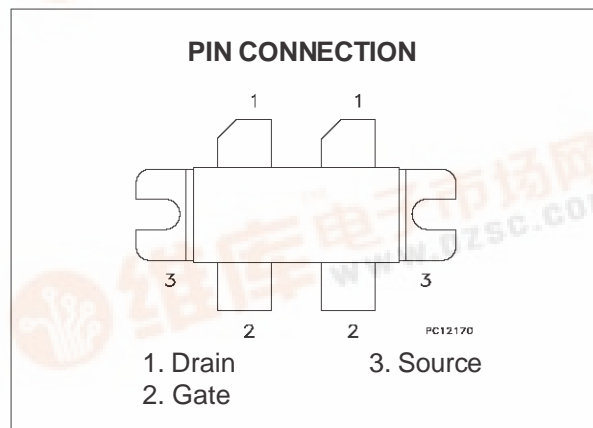
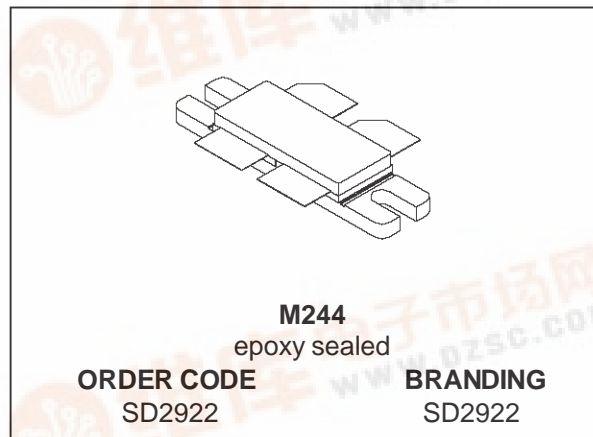

ABSOLUTE MAXIMUM RATINGS (T_{case} = 25 °C)

Symbol	Parameter	Value	Unit
V _{(BR)DSS}	Drain Source Voltage	125	V
V _{DGR}	Drain-Gate Voltage (R _{GS} = 1MΩ)	125	V
V _{GS}	Gate-Source Voltage	±20	V
I _D	Drain Current	40	A
P _{DISS}	Power Dissipation	500	W
T _j	Max. Operating Junction Temperature	+200	°C
T _{STG}	Storage Temperature	-65 to 150	°C

THERMAL DATA

R _{th(j-c)}	Junction-Case Thermal Resistance	0.35	°C/W
R _{th(c-s)}	Case Heatsink Thermal Resistance *	0.12	°C/W

* Determined using a flat aluminum or copper heatsink with thermal compound applied (Dow Corning 340 or equivalent).



SD2922

ELECTRICAL SPECIFICATION ($T_{\text{case}} = 25\text{ }^{\circ}\text{C}$)

STATIC (per section)

Symbol	Parameter		Min.	Typ.	Max.	Unit
$V_{(\text{BR})\text{DSS}}$	$V_{\text{GS}} = 0\text{ V}$	$I_{\text{DS}} = 100\text{ mA}$	125			V
I_{DSS}	$V_{\text{GS}} = 0\text{ V}$	$V_{\text{DS}} = 50\text{ V}$			5	mA
I_{GSS}	$V_{\text{GS}} = 20\text{ V}$	$V_{\text{DS}} = 0\text{ V}$			5	μA
$V_{\text{GS(Q)}}$	$V_{\text{DS}} = 10\text{ V}$	$I_{\text{D}} = 250\text{ mA}$	1		5	V
$V_{\text{DS(on)}}$	$V_{\text{GS}} = 10\text{ V}$	$I_{\text{D}} = 10\text{ A}$			3	V
gfs	$V_{\text{DS}} = 10\text{ V}$	$I_{\text{D}} = 5\text{ A}$	4			mho
C_{ISS}	$V_{\text{GS}} = 0\text{ V}$	$V_{\text{DS}} = 50\text{ V}$		411		pF
C_{OSS}	$V_{\text{GS}} = 0\text{ V}$	$V_{\text{DS}} = 50\text{ V}$		198		pF
C_{RSS}	$V_{\text{GS}} = 0\text{ V}$	$V_{\text{DS}} = 50\text{ V}$		27		pF

REF. 1021306E

DYNAMIC

Symbol	Parameter		Min.	Typ.	Max.	Unit
P_{OUT}	$f = 175\text{ MHz}$	$V_{\text{DD}} = 50\text{ V}$ $I_{\text{DQ}} = 500\text{ mA}$	300			W
G_{PS}	$f = 175\text{ MHz}$	$V_{\text{DD}} = 50\text{ V}$ $P_{\text{out}} = 300\text{ W}$ $I_{\text{DQ}} = 500\text{ mA}$	12.5	15		dB
η_{D}	$f = 175\text{ MHz}$	$V_{\text{DD}} = 50\text{ V}$ $P_{\text{out}} = 300\text{ W}$ $I_{\text{DQ}} = 500\text{ mA}$	50	60		%
Load Mismatch	$f = 175\text{ MHz}$	$V_{\text{DD}} = 50\text{ V}$ $P_{\text{out}} = 300\text{ W}$ $I_{\text{DQ}} = 500\text{ mA}$ All Phase Angles	5:1			VSWR

IMPEDANCE DATA

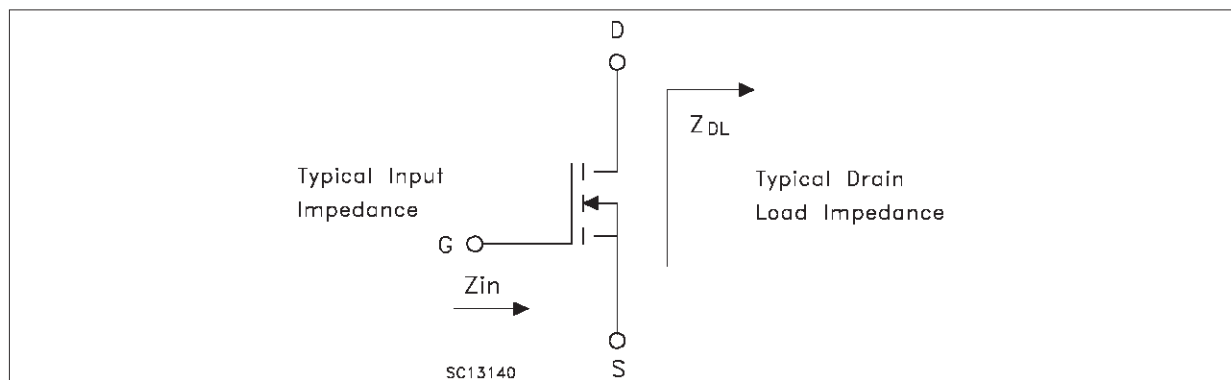

FREQ.	$Z_{\text{IN}} (\Omega)$	$Z_{\text{DL}} (\Omega)$
175 MHz	$0.92 - j 0.14$	$3.17 + j 4.34$

Measured Gate to Gate and Drain to Drain, respectively.

Maximum Thermal Resistance vs Case Temperature

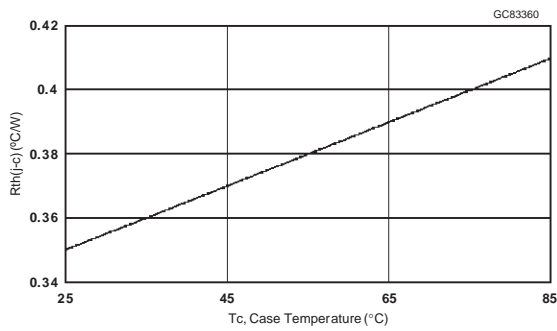

DC Safe Operating Area

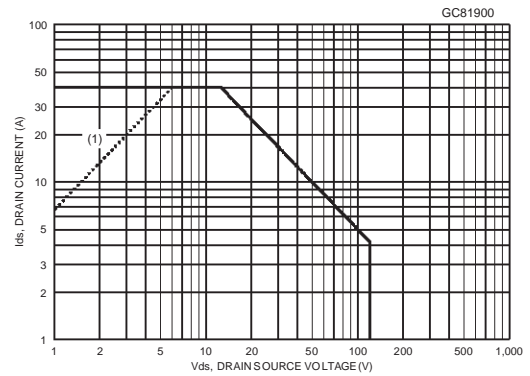

(1) Current in this area may be limited by $R_{DS(on)}$
Two sides, each section equally loaded

Capacitance vs Drain-Source Voltage

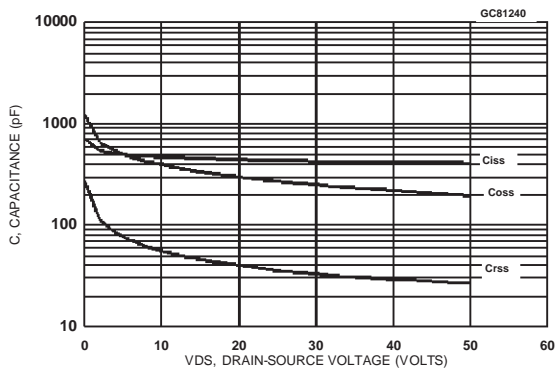

Drain Current vs Gate Voltage

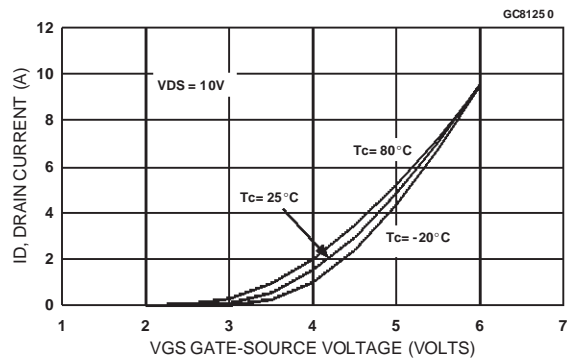

Gate Voltage vs Case Temperature

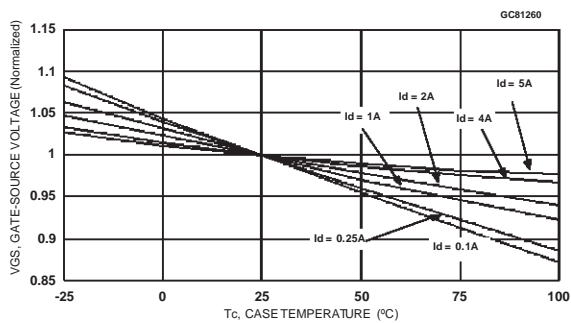

TYPICAL PERFORMANCE (175 MHz)

Output Power vs Input Power

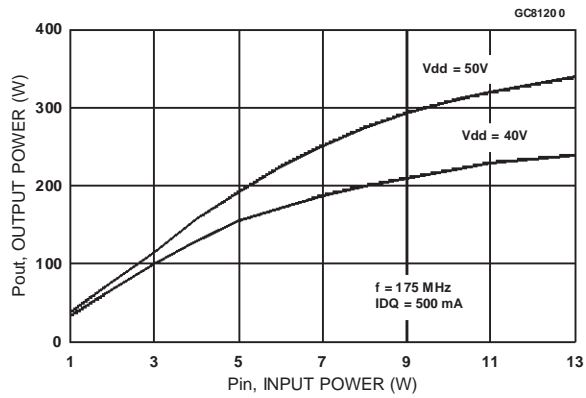

Output Power vs Input Power

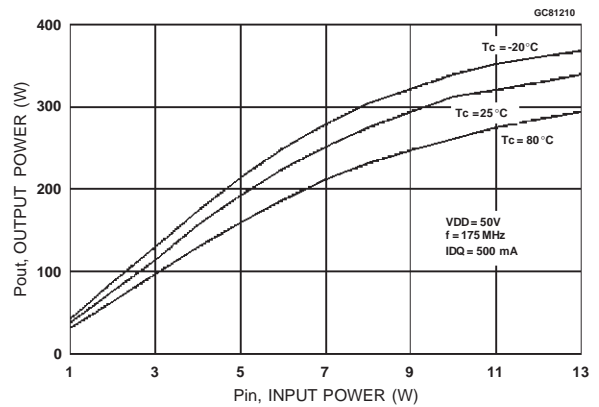

Output Power vs Supply Voltage

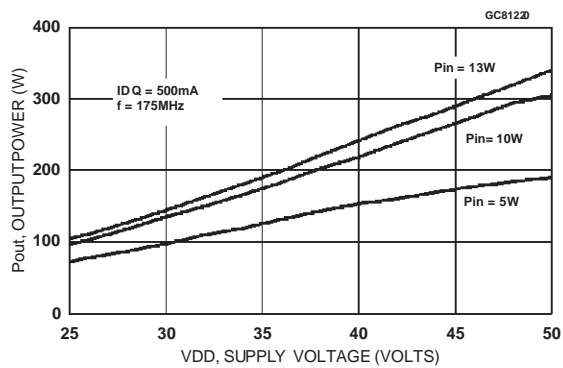

Output Power vs Gate Voltage

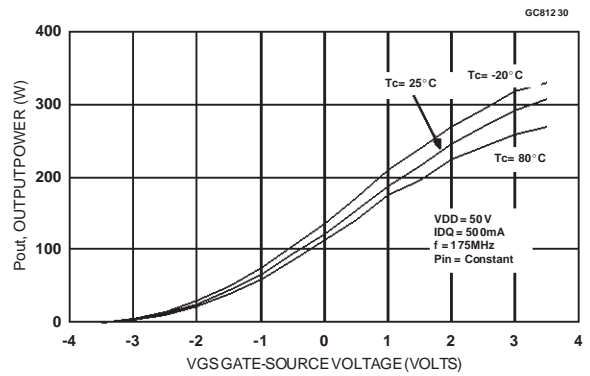

175 MHz Test Circuit Schematic (Production Test Circuit)

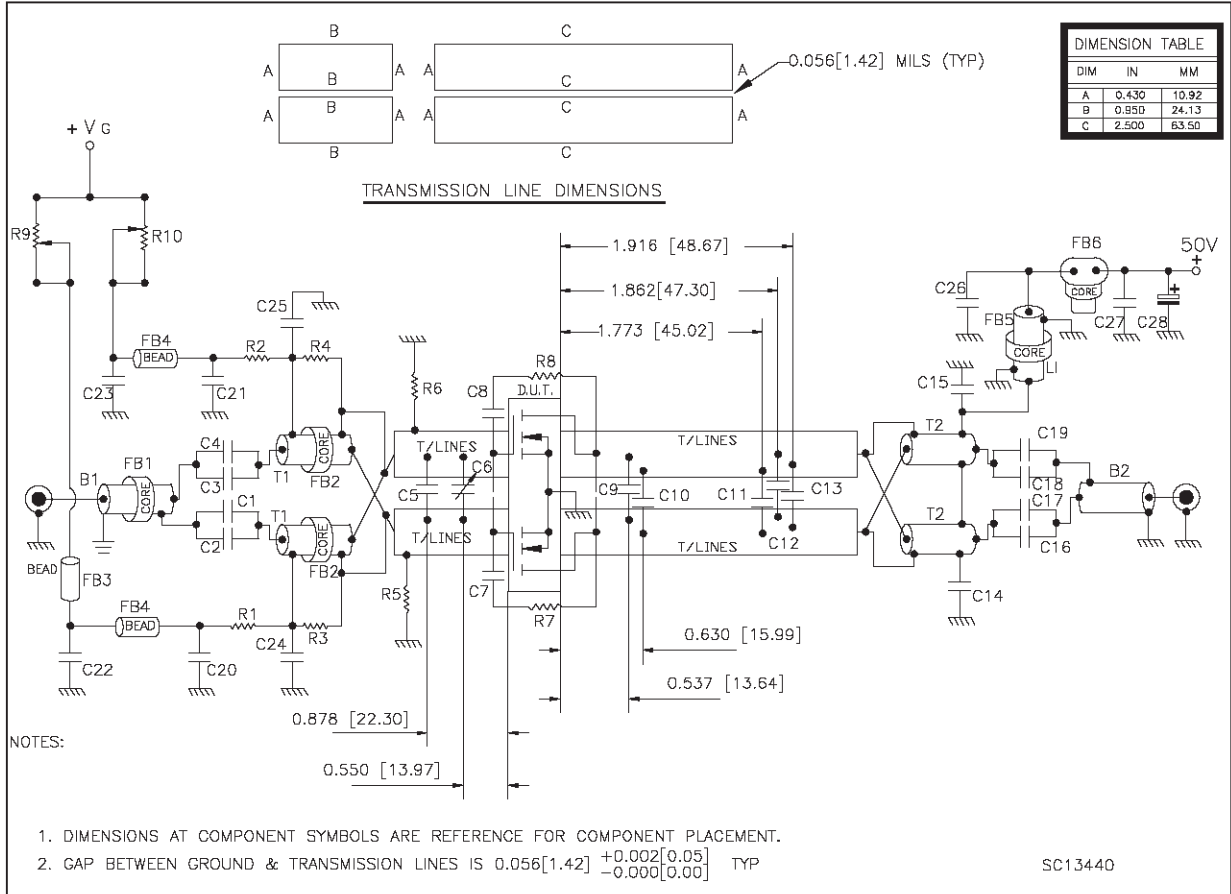

REF. 1022256B

SD2922

175 MHz Test Circuit Component Part List

Component	Part Number	Vendor	Description
R1/R2	CR2412-1W-471JB	VENKEL	470 Ohm 1 W, Surface Mount Chip Resistor
R3/R4		DALE	360 Ohm 0.5 W, Carbon Comp. Axial Lead Resistor or Equiv.
R5/R6	CR2512-1W-471JB	VENKEL	470 Ohm 1 W, Surface Mount Chip Resistor
R7/R8	RS 2B	DALE	560 Ohm 2 W, Resistor Two Turn Wire Air-Wound Axial Lead Resistor
R9/R10	534 - 1 - 1 - 203	SPECTROL	20 KOhm 3.09 W, 10 Turn Wirewound Precision Potentiometer
C1/C4	ATC130B681KP50X	ATC	680 pF ATC 130B Surface Mount Ceramic Chip Capacitor
C2/C7/C8 C17/C19 C20/C21	ATC200B103MW50X	ATC	10000 pF ATC 200B Surface Mount Ceramic Chip Capacitor
C3	ATC200B122MW50X	ATC	10000 pF ATC 200B Surface Mount Ceramic Chip Capacitor
C5	ATC100B750KP500X	ATC	75 pF ATC 100B Surface Mount Ceramic Chip Capacitor
C6	406	ARCO	ST40 25 pF -115pF Miniature Variable Trimmer
C9/C10	ATC100B470KP500X	ATC	47 pF ATC 100B Surface Mount Ceramic Chip Capacitor
C11-C12 C13	ATC100B430KP500X	ATC	43 pF ATC 100B Surface Mount Ceramic Chip Capacitor
C14-C15 C24-C25	ATC700B122MW50X	ATC	1200 pF ATC 700B Surface Mount Ceramic Chip Capacitor
C16-C18	ATC700B471MP200X	ATC	470 pF ATC 700B Surface Mount Ceramic Chip Capacitor
C22-C23	GRM43-4X7R104K500	MURATA	0.1 μ F / 500V Surface Mount Ceramic Chip Capacitor
C26	C1812X7R501-103KNE	VENKEL	0.01 μ F / 500V Surface Mount Ceramic Chip Capacitor
C27	GRM43-4X7R-104K500	MURATA	0.01 μ F / 500V Surface Mount Ceramic Chip Capacitor
C28	SME63T10RM	MARCON	10 μ F / 63 V Aluminum Electrolytic Axial Lead Capacitor
B1			50 Ohm RG316, O.D. 0.076[1.93] L=11.80[299.72] Flexible Coaxial Cable 4 Turns thru Fair-rite Bead
B2	83242	BELDEN	50 Ohm RG-142B O.D. 0.165[4.19] L=11.80[299.72] Flexible Coaxial Cable
T1			R.F. Transformer 4:1, 25 Ohm RG316-25, O.D 0.080[2.03] L=5.90[149.86] Flexible Coaxial Cable 2 Turns Thru Fair-rite Multi-aperture Core
T2	UT141-25	MICRO COAX	R.F. Transformer 1:4, 25 Ohm Semi-rigid Coaxial Cable O.D. 0.141[3.58] L=5.90[149.86]
L1	83242	BELDEN	Inductor λ 1/4 Wave 50 Ohm O.D. 0.165[4.19] L=11.80[299.72] Flexible Coaxial Cable 2 Turns Thru Fair-rite Bead
FB1	2643665802	FAIR-RITE CORP	Shield Bead
FB2	2843009902	FAIR-RITE CORP	Multi-aperture Core
FB3	2518068007	FAIR-RITE CORP	Multilayer Ferrite Chip Bead (Surface Mount)
FB4	2743021447	FAIR-RITE CORP	Surface Mount Emi Shield Bead
FB5	2643801002	FAIR-RITE CORP	Shield Bead
FB6	2843010402	FAIR-RITE CORP	Multi-aperture Core
PCB	G0600M1016QA	ROGERS CORP	Woven Glass Reinforced PTFE Microwave Laminate 0.06", 1oz EDCu, Both sides, $\epsilon_r = 2.55$

175 MHz Test Circuit Photomaster

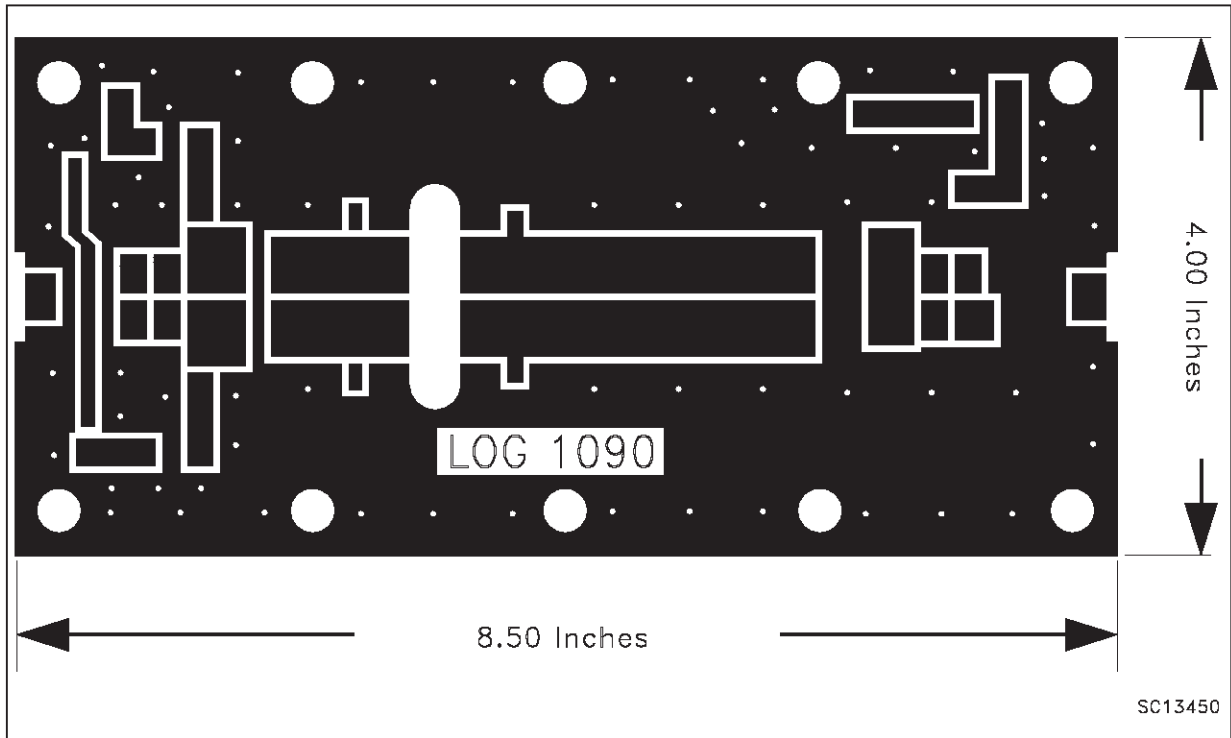

175 MHz Text Fixture

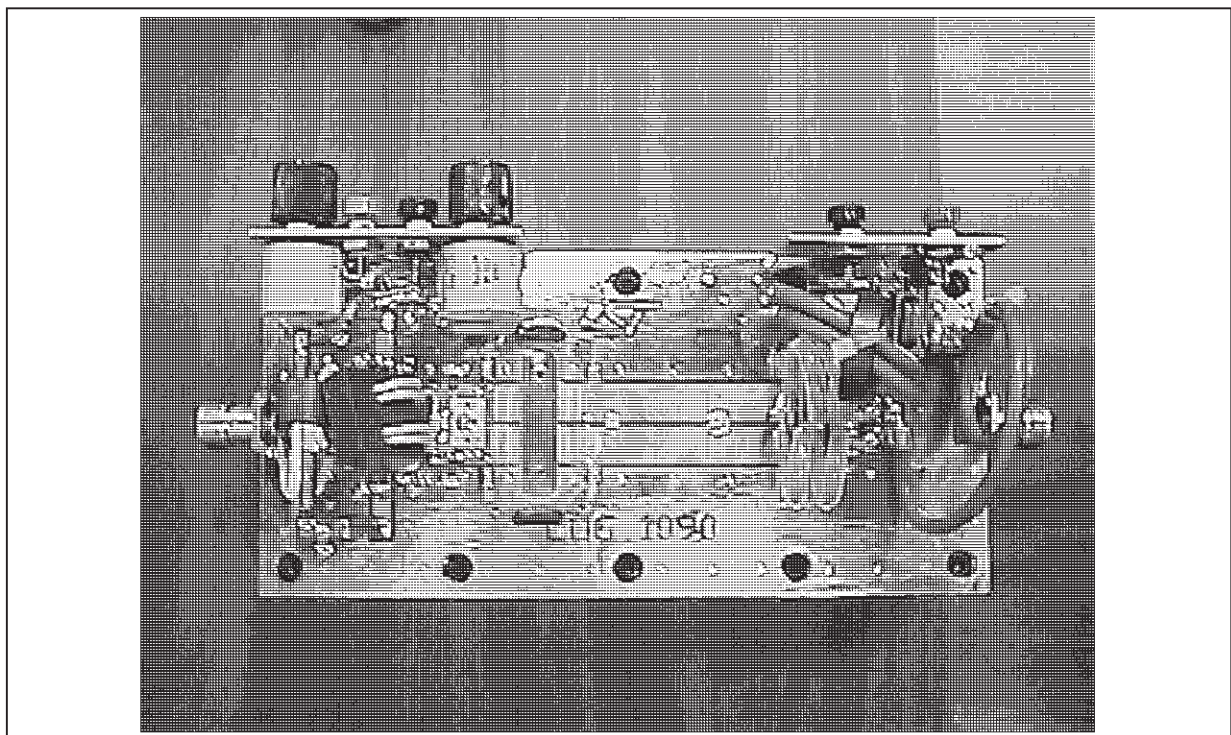

TYPICAL BROADBAND DATA (175 - 230 MHz)

Input Power vs Frequency

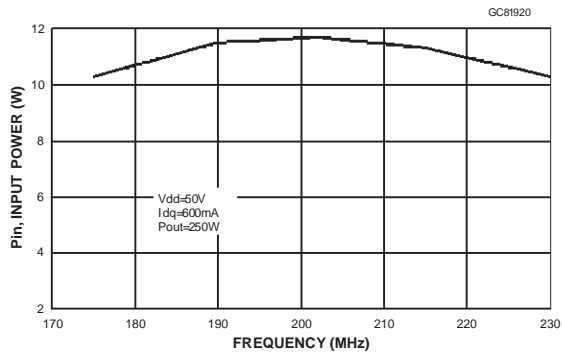

Power Gain vs Frequency

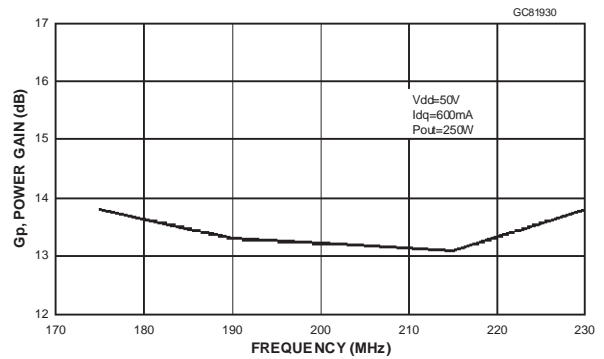

Efficiency vs Frequency

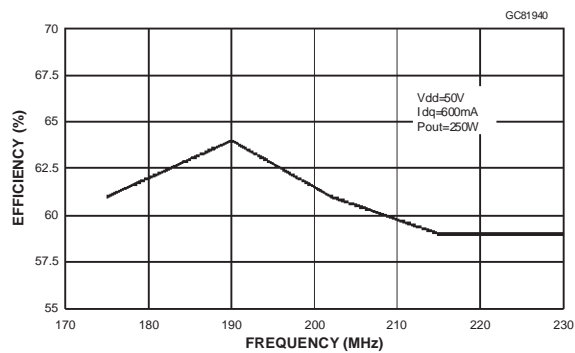

Return Loss vs Frequency

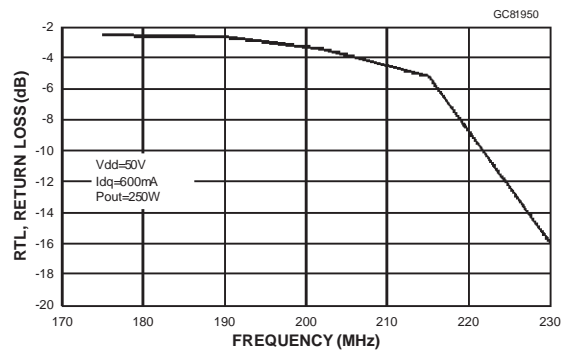

1 dB Compression

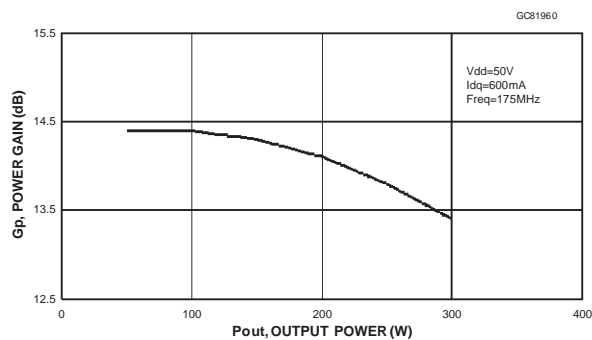

1 dB Compression

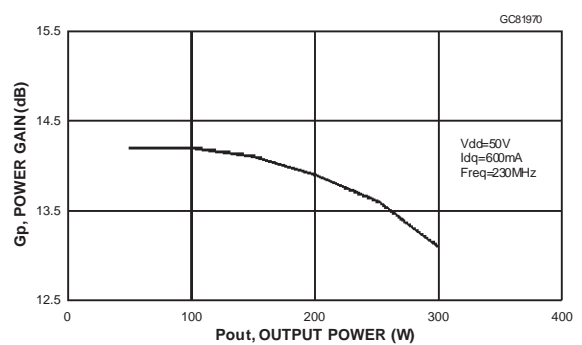

175 - 230 MHz Circuit Layout (Engineering Fixture)

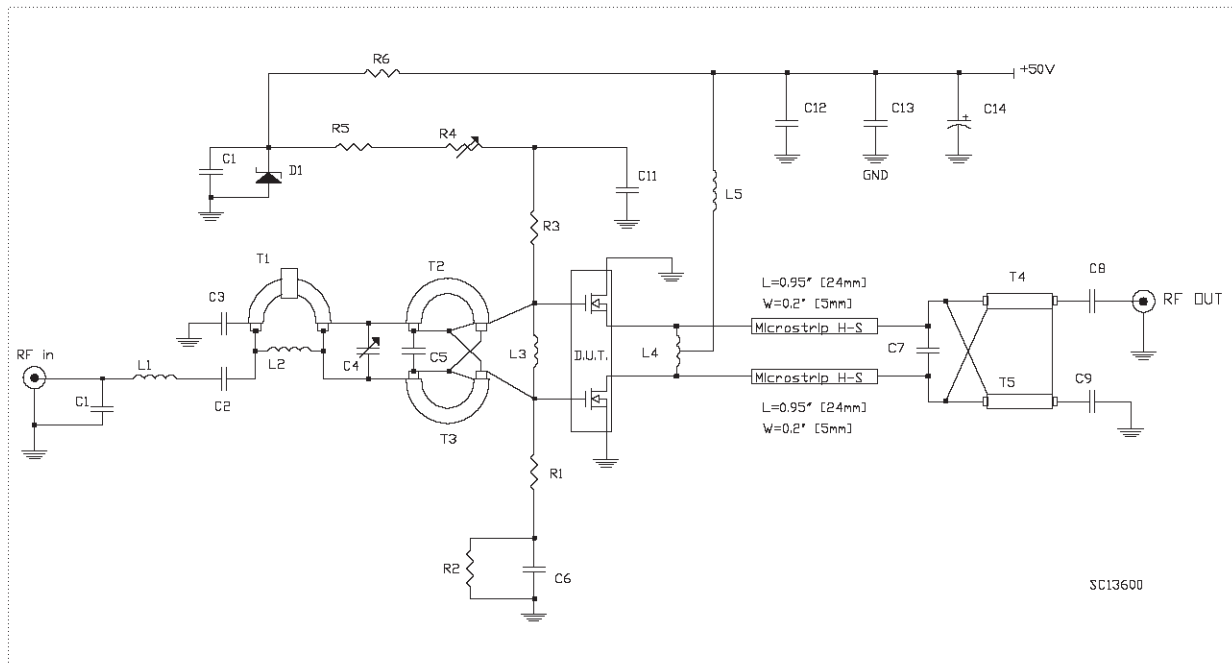

175 -230 MHz Circuit Layout Component Part List

PCB	1/32" Woven Fiberglass 0.030 Cu, 2 sides, er=4.8
T1	50 Ohm Flexible Coax Cable OD 0.06", 3" Long. Ferrite Core NEOSIDE
T2 / T3	9:1 Transformer, 16.5 Ohm Flexible Coax Cable OD 0.1", 3" Long
T4 / T5	4:1 Transformer, 25 Ohm Flexible Coax Cable OD 0.06", 5" Long
C1	8.2 pF Ceramic Cap
C2/C3	100 pF Chip Cap
C4	2-18 pF Variable Cap
C5	47 pF Ceramic Cap
C6 / C11	47 nF Ceramic Cap
C7	56 pF ATC Chip Cap
C8 / C9 / C13	470 pF ATC Chip Cap
C10	100 nF Ceramic Cap
C12	2x330 nF / 500 V Cap
C14	10 nF / 63 V Electrolytic Cap
R1 / R3	47 Ohm Resistor
R2	6.8K Ohm Chip Resistor
R4	4.7K Ohm MultiTurns Trim Resistor
R5	8.2K Ohm Resistor
R6	3.3K Ohm / 5 W Resistor
D1	6.8 V Zener Diode
L1	20 nH Inductor
L2	70 nH Inductor
L3	30 nH Inductor
L4	10 nH Inductor
L5	15 nH Inductor

TYPICAL BROADBAND DATA (88 - 108 MHz)

Input Power vs Frequency

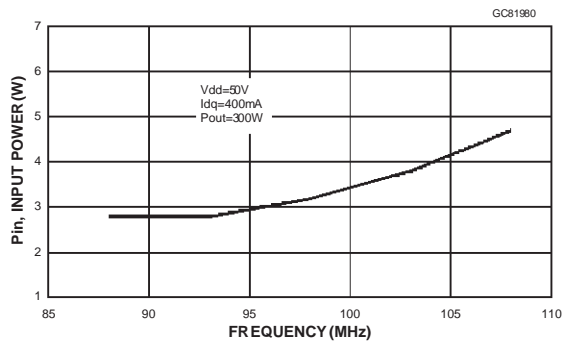

Power Gain vs Frequency

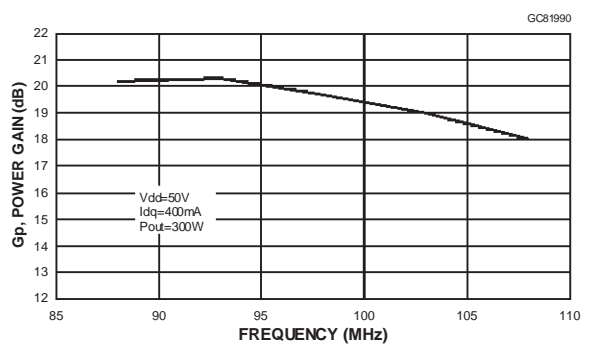

Efficiency vs Frequency

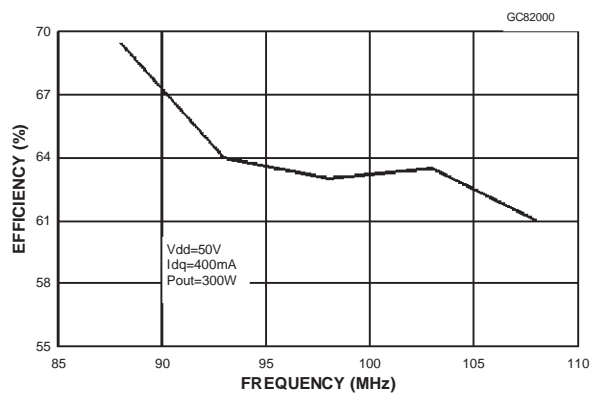

Return Loss vs Frequency

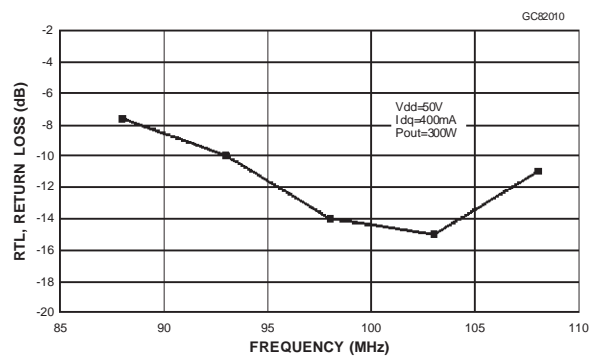

88 - 108 MHz Circuit Layout (Engineering Fixture)

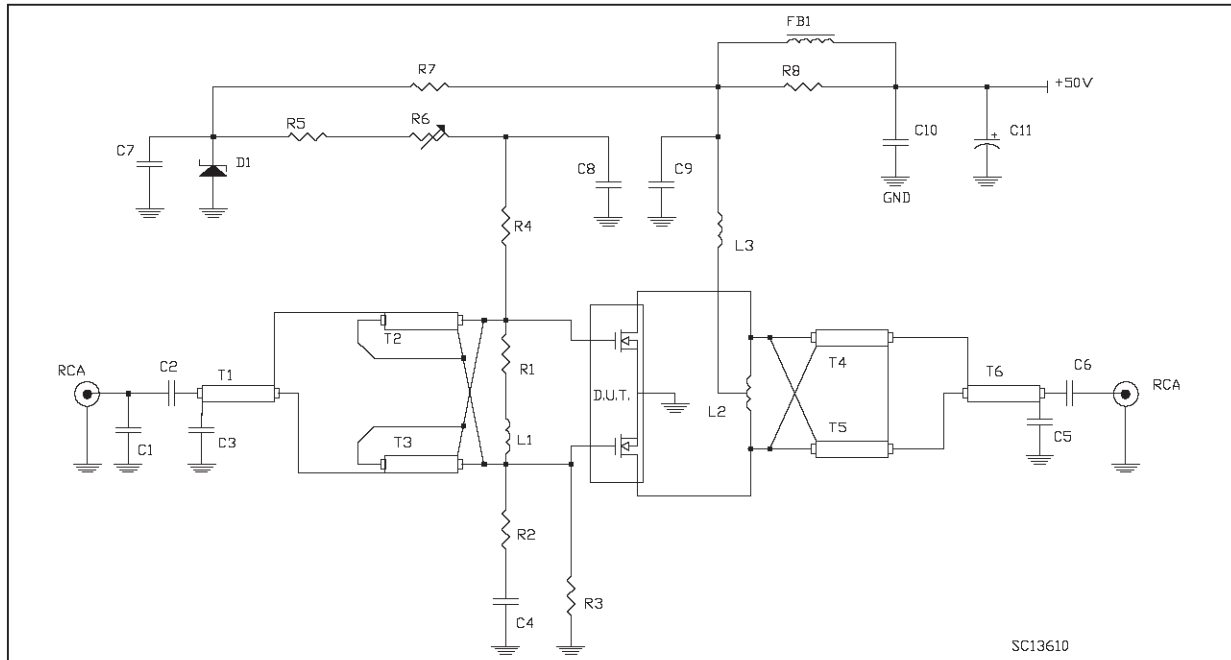

88 -108 MHz Circuit Layout Component Part List

PCB	1/32" Woven Fiberglass 0.030 Cu, 2 sides, er =4.8
T1	50 Ohm Flexible Coax Cable OD 0.06", 5" Long
T2 / T3	9:1 Transformer, 25 Ohm Flexible Coax Cable OD 0.1", 3.9". Ferrite Core NEOSIDE
T4 / T5	4:1 Transformer, 25 Ohm Flexible Coax Cable OD 0.1", 5" Long
T6	50 Ohm Flexible Coax Cable OD 0.1", 5" Long
FB1	VK200
C1	10 pF Ceramic Cap
C2 / C3 / C4 / C7 / C8	1 nF Chip Cap
C5 / C6	1 nF ATC chip Cap
C9	470 pF ATC Chip Cap
C10	100 nF Chip Cap
C11	100 uF / 63 V Electrolytic Cap
R1	56 Ohm Resistor
R2/R4	10 Ohm Chip Resistor
R3	10K Ohm Resistor
R5	5.6K Ohm Resistor
R6	10K Ohm, 10 Turn Trim Resistor
R7	3.3K Ohm / 5 W Resistor
R8	15 Ohm / 1 W Resistor
D1	6.8 V Zener Diode
L1	10 nH Inductor
L2	40 nH Inductor
L3	70 nH Inductor

M244 (.400 x .860 4/L BAL N/HERM W/FLG) MECHANICAL DATA

DIM.	mm			inch		
	MIN.	TYP.	MAX.	MIN.	TYP.	MAX.
A	5.59		5.84	0.220		0.230
B		5.33			0.210	
C	3.05		3.30	0.120		0.130
D	9.65		9.91	0.380		0.390
E	19.81		20.83	0.780		0.820
F		11.05			0.435	
G		27.94			1.100	
H	33.91		34.16	1.335		1.345
I	0.08		0.18	0.003		0.007
J	1.52		1.78	0.060		0.070
K	2.54		2.92	0.100		0.115
L			5.84			0.230
M	10.03		10.34	0.395		0.407
N	21.59		22.10	0.850		0.870

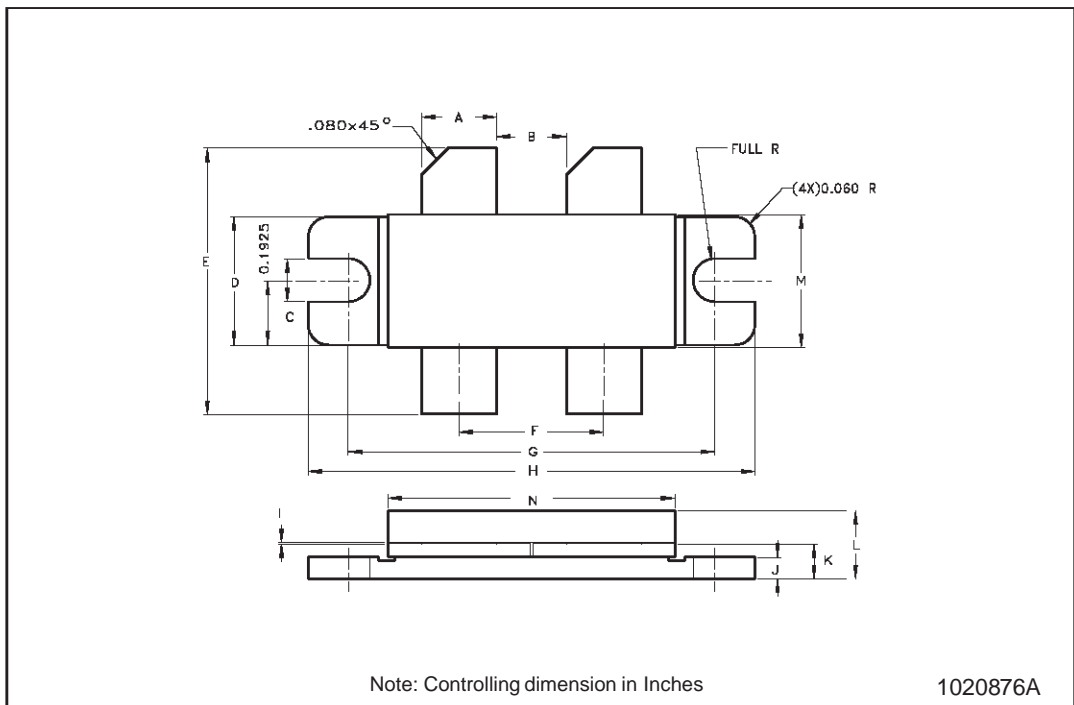

Information furnished is believed to be accurate and reliable. However, STMicroelectronics assumes no responsibility for the consequences of use of such information nor for any infringement of patents or other rights of third parties which may result from its use. No license is granted by implication or otherwise under any patent or patent rights of STMicroelectronics. Specification mentioned in this publication are subject to change without notice. This publication supersedes and replaces all information previously supplied. STMicroelectronics products are not authorized for use as critical components in life support devices or systems without express written approval of STMicroelectronics.

The ST logo is a trademark of STMicroelectronics

© 1999 STMicroelectronics – Printed in Italy – All Rights Reserved

STMicroelectronics GROUP OF COMPANIES

Australia - Brazil - China - Finland - France - Germany - Hong Kong - India - Italy - Japan - Malaysia - Malta - Morocco -
Singapore - Spain - Sweden - Switzerland - United Kingdom - U.S.A.

<http://www.st.com>