



SD2923

RF POWER TRANSISTORS HF/VHF/UHF N-CHANNEL MOSFETs

- GOLD METALLIZATION
- EXCELLENT THERMAL STABILITY
- COMMON SOURCE CONFIGURATION
- P_{out} = 300W MIN. WITH 16 dB GAIN @ 30 MHz
- THERMALLY ENHANCED PACKAGING

DESCRIPTION

The SD2923 is a gold metallized N-Channel MOS field-effect RF power transistor. It is intended for use in 50 V DC large signal applications up to 150 MHz

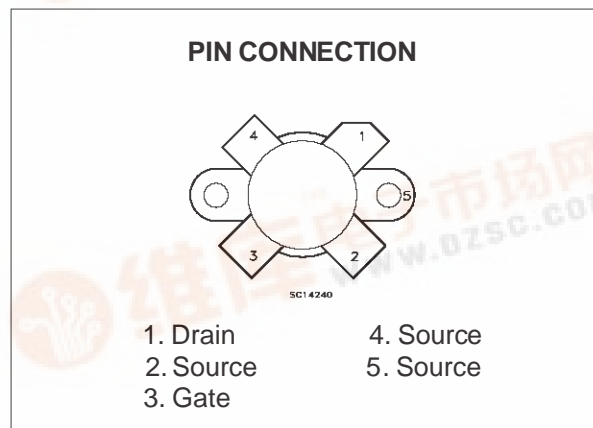
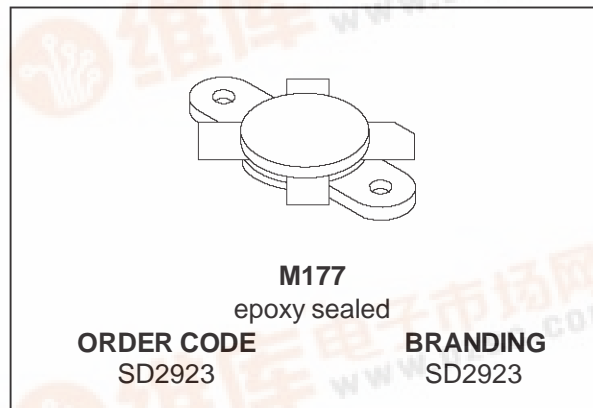

ABSOLUTE MAXIMUM RATINGS (T_{case} = 25 °C)

Symbol	Parameter	Value	Unit
V _{(BR)DSS}	Drain Source Voltage	125	V
V _{DGR}	Drain-Gate Voltage (R _{GS} = 1MΩ)	125	V
V _{GS}	Gate-Source Voltage	±20	V
I _D	Drain Current	40	A
P _{DISS}	Power Dissipation	648	W
T _j	Max. Operating Junction Temperature	200	°C
T _{STG}	Storage Temperature	-65 to 150	°C

THERMAL DATA

R _{th(j-c)}	Junction-Case Thermal Resistance	0.27	°C/W
R _{th(c-s)}	Case-Heatsink Thermal Resistance *	0.15	°C/W

* Determined using a flat aluminum or copper heatsink with thermal compound applied (Dow Corning 340 or equivalent).



SD2923

ELECTRICAL SPECIFICATION (T_{case} = 25 °C)

STATIC

Symbol	Parameter			Min.	Typ.	Max.	Unit
V _{(BR)DSS}	V _{GS} = 0V	I _{DS} = 200 mA		125			V
I _{DSS}	V _{GS} = 0V	V _{DS} = 50 V				10	mA
I _{GSS}	V _{GS} = 20V	V _{DS} = 0 V				10	μA
V _{GS(Q)}	V _{DS} = 10V	I _D = 250 mA		2		5	V
V _{DS(ON)}	V _{GS} = 10V	I _D = 20 A				3	V
g _{FS}	V _{DS} = 10V	I _D = 10 A		8			mho
C _{ISS}	V _{GS} = 0V	V _{DS} = 50 V	f = 1 MHz		825		pF
C _{OSS}	V _{GS} = 0V	V _{DS} = 50 V	f = 1 MHz		390		pF
C _{RSS}	V _{GS} = 0V	V _{DS} = 50 V	f = 1 MHz		55		pF

REF. 1019132C

DYNAMIC

Symbol	Parameter				Min.	Typ.	Max.	Unit
P _{OUT}	f = 30 MHz	V _{DD} = 50 V	I _{DQ} = 250 mA		300	400		W
G _{PS}	f = 30 MHz	V _{DD} = 50 V	P _{out} = 300 W	I _{DQ} = 250 mA	16	22		dB
η _D	f = 30 MHz	V _{DD} = 50 V	P _{out} = 300 W	I _{DQ} = 250 mA	50	55		%
Load Mismatch	f = 30 MHz	V _{DD} = 50 V	P _{out} = 300 W	I _{DQ} = 250 mA	5:1			VSWR
	All Phase Angles							

IMPEDANCE DATA

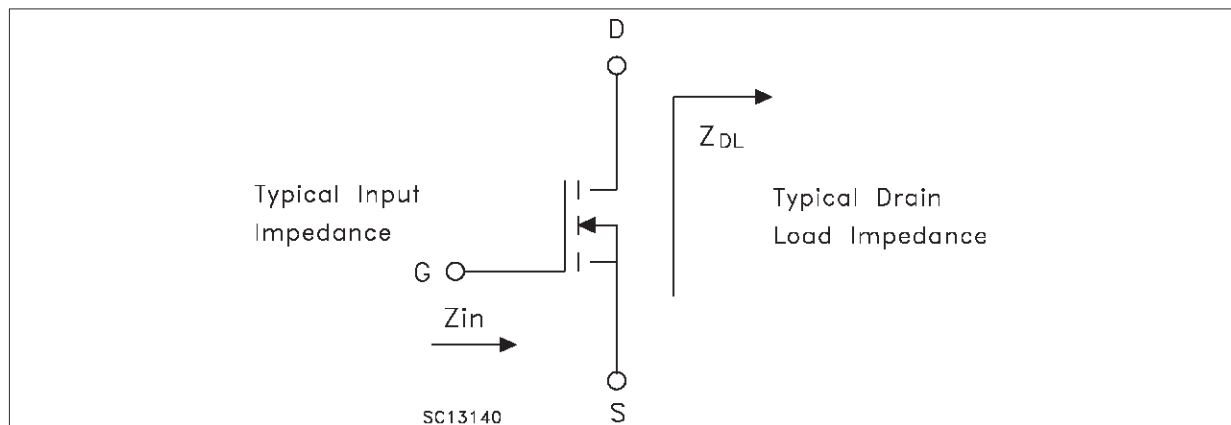

FREQ.	Z _{IN} (Ω)	Z _{DL} (Ω)
30 MHz	1.8 - j 0.2	2.8 + j 2.3
108 MHz	1.9 + j 0.2	1.6 + j 1.4
150 MHz	1.9 + j 0.3	1.5 + j 1.6

TYPICAL PERFORMANCE

Capacitance vs Drain-Source Voltage

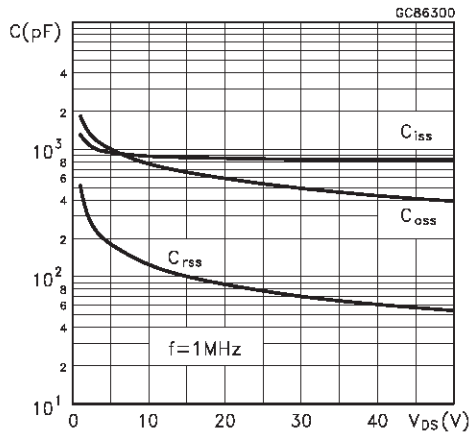

Maximum Thermal Resistance vs Case Temperature

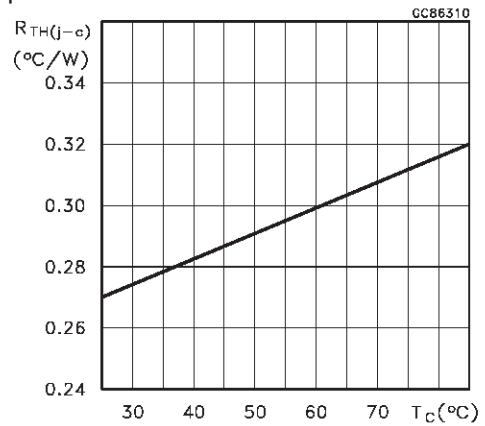

Drain Current vs Gate Voltage

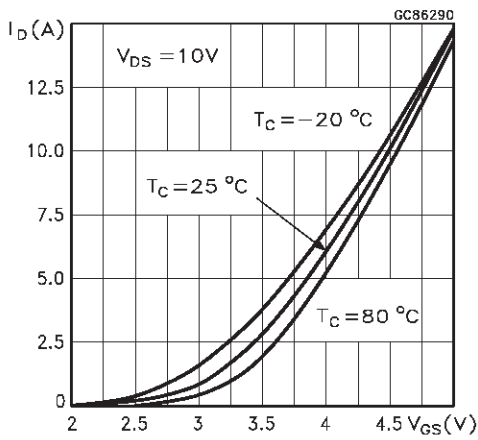

Gate-Source Voltages vs Case Temperature

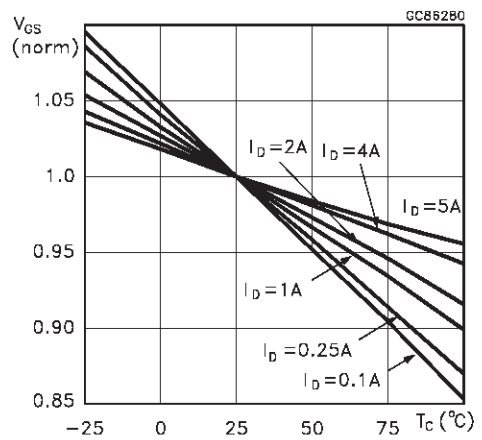

TYPICAL PERFORMANCE

Output Power vs Input Power

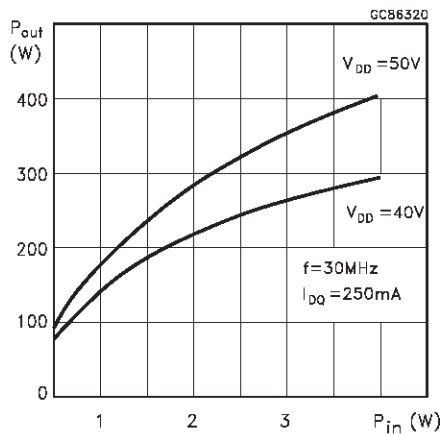

Output Power vs Input Power

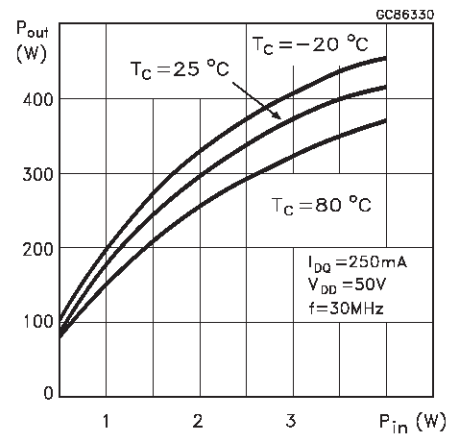

Output Power vs Voltage Supply

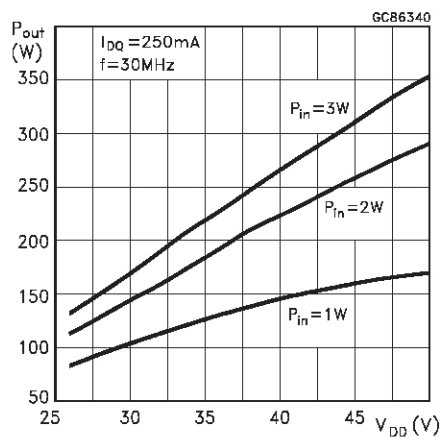

Output Power vs Gate Voltage

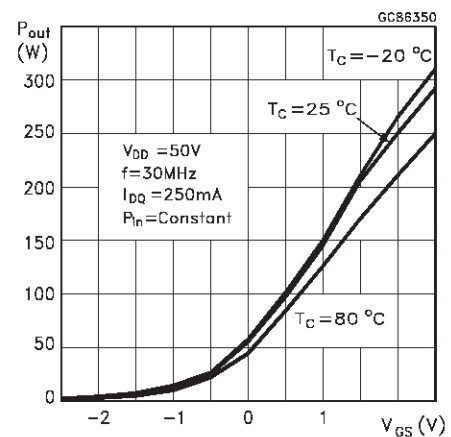

Power Gain vs Output Power

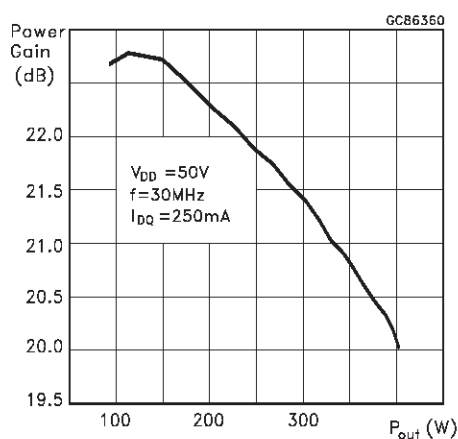

Efficiency vs Output Power

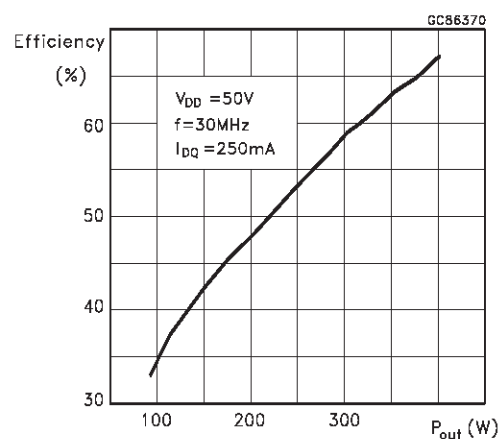

30 MHz Test Circuit Schematic

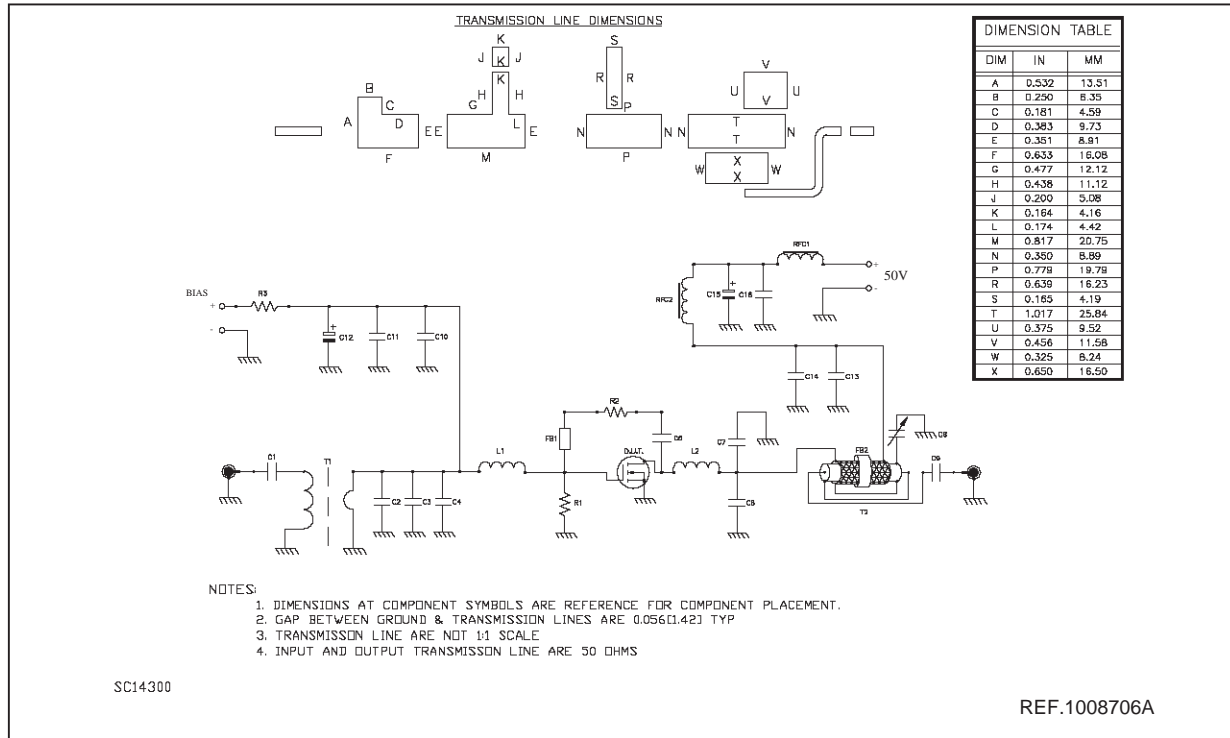

30 MHz Test Circuit Component Part List

COMPONENT	PART N.	VENDOR	DESCRIPTION
C16	ATC200B103MW50X	ATC	10000 pF ATC 200B SURFACE MOUNT CERAMIC CHIP CAPACITOR
C15	SKR101M1JG13V7	MALLORY	100 μF / 63V ALUMINUM ELECTROLYTICS RADIAL LEAD CAPACITOR
C14	ATC200B103MW50X	ATC	10000 pF ATC 200B SURFACE MOUNT CERAMIC CHIP CAPACITOR
C13	ATC700B122MW50X	ATC	1200 pF ATC 700B SURFACE MOUNT CERAMIC CHIP CAPACITOR
C12	SKR470M1JF11V	MALLORY	47 μF / 63V ALUMINUM ELECTROLYTICS RADIAL LEAD CAPACITOR
C11	ATC200B103MW50X	ATC	10000 pF ATC 200B SURFACE MOUNT CERAMIC CHIP CAPACITOR
C10	ATC200B103MW50X	ATC	10000 pF ATC 200B SURFACE MOUNT CERAMIC CHIP CAPACITOR
C9	C1812X7R501-103KNE	VENKEL	0.01 μF / 500V SURFACE MOUNT CERAMIC CHIP CAPACITOR
C8	TYPE 468	ARCO	175-680 pF TYPE 46 STANDARD TRIMMER CAPACITOR
C7	ATC700B301JP200X	ATC	300 pF ATC 700B SURFACE MOUNT CERAMIC CHIP CAPACITOR
C6	ATC700B511MW100X	ATC	510 pF ATC 700B SURFACE MOUNT CERAMIC CHIP CAPACITOR
C5	ATC200B103MW50X	ATC	10000 pF ATC 200B SURFACE MOUNT CERAMIC CHIP CAPACITOR
C4	ATC700B301JP200X	ATC	300 pF ATC 700B SURFACE MOUNT CERAMIC CHIP CAPACITOR
C3	ATC700B751MW50X	ATC	750 pF ATC 700B SURFACE MOUNT CERAMIC CHIP CAPACITOR
C2	ATC700B751MW50X	ATC	750 pF ATC 700B SURFACE MOUNT CERAMIC CHIP CAPACITOR
C1	C1812X7R501-103KNE	VENKEL	0.01 μF / 500V SURFACE MOUNT CERAMIC CHIP CAPACITOR
R3	CR2512-1W-102JB	VENKEL	1 K OHM 1 W SURFACE MOUNT CHIP RESISTOR
R2	RS-2B	DALE	560 OHM 2 W WIRE-WOUND AXIAL LEAD RESISTOR
R1	CR2512-1W-102JB	VENKEL	1 K OHM 1 W SURFACE MOUNT CHIP RESISTOR
T2	83242	BELDEN	RG-142B/U 50 OHM COAXIAL CABLE OD = 0.165[4.18] L=15"[381.00] COVERED - WITH 15"[381.00] TINNED COPPER TUBULAR BRAID 13/65"[5.1] WIDTH
T1	TYPE 2170 RT-600-9	ALPHA COMM CONCEPTS, Inc	HF 2-30 MHZ SURFACE MOUNT 9:1 (Impedance Ratio) TRANSFORMER (43 Material)
L2	TYPE 8011	BELDEN	1 3/4 TURN AIR-WOUND 12AWG ID=0.250[6.34] BUS BAR WIRE
L1	TYPE 8074	BELDEN	1 3/4 TURN AIR-WOUND 16AWG ID=0.219[5.56] POLY-COATED MAGNET WIRE
RFC2	2643B01102	FAIR-RITE CORP	3 TURNS 14AWG WIRE THROUGH FAIR RITE TOROID
RFC1	2643B01102	FAIR-RITE CORP	3 TURNS 14AWG WIRE THROUGH FAIR RITE TOROID
FB2	5967002701	FAIR-RITE CORP	TOROID
FB1	2743019447	FAIR-RITE CORP	SURFACE MOUNT EMI SHIELD BEAD
PCB	G0300M1026QB	ROGERS CORP.	ULTRALAM 2000. 0.030 THK, Er = 2.55, 2 Oz ED CU BOTH SIDES
COMPONENT	PART N.	VENDOR	DESCRIPTION

SC1421D

SD2923

30 MHz Test Circuit Photomaster

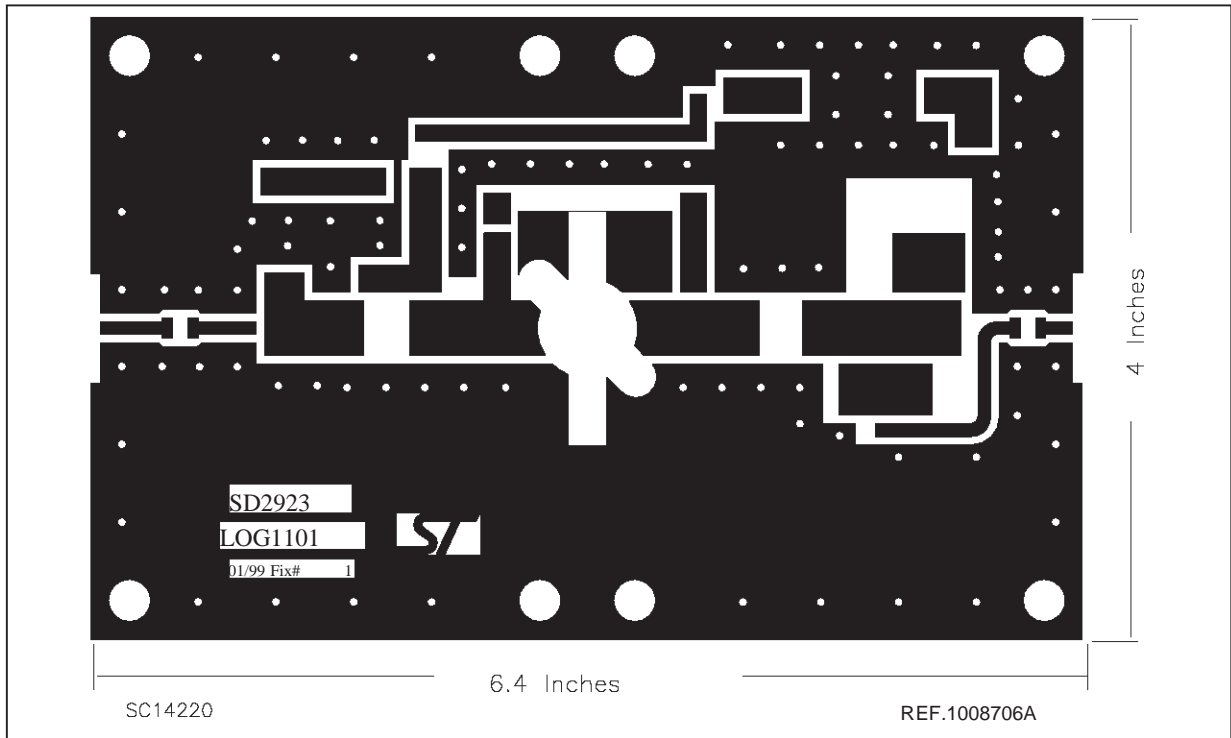

30 MHz Production Test Fixture

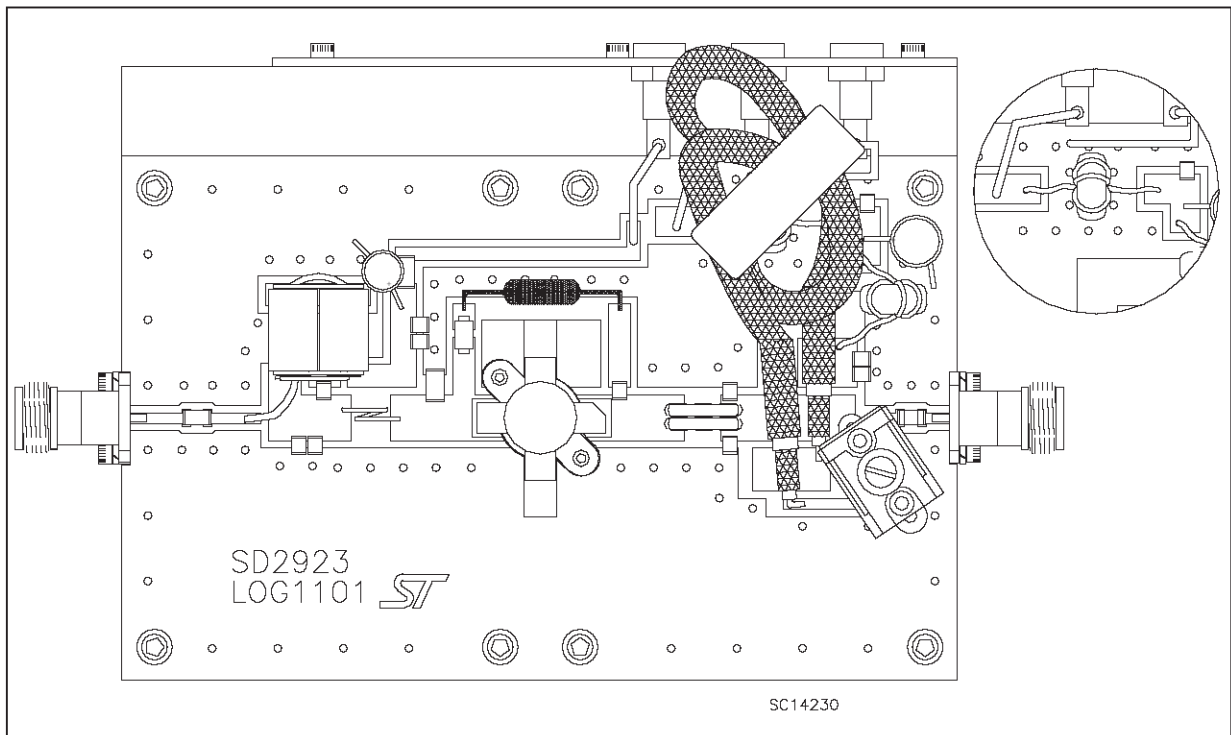

M177 (.550 DIA. 4/L N/HERM W/FLG) MECHANICAL DATA

DIM.	mm			inch		
	MIN.	TYP.	MAX.	MIN.	TYP.	MAX.
A	5.72		5.97	0.225		0.235
B	6.73		6.96	0.265		0.275
C	21.84		22.10	0.860		0.870
D	28.70		28.96	1.130		1.140
E	13.84		14.10	0.545		0.555
F	0.08		0.18	0.003		0.007
G	2.49		2.74	0.098		0.108
H	3.81		4.32	0.150		0.170
I			7.11			0.280
J	27.43		28.45	1.080		1.120
K	15.88		16.13	0.625		0.635

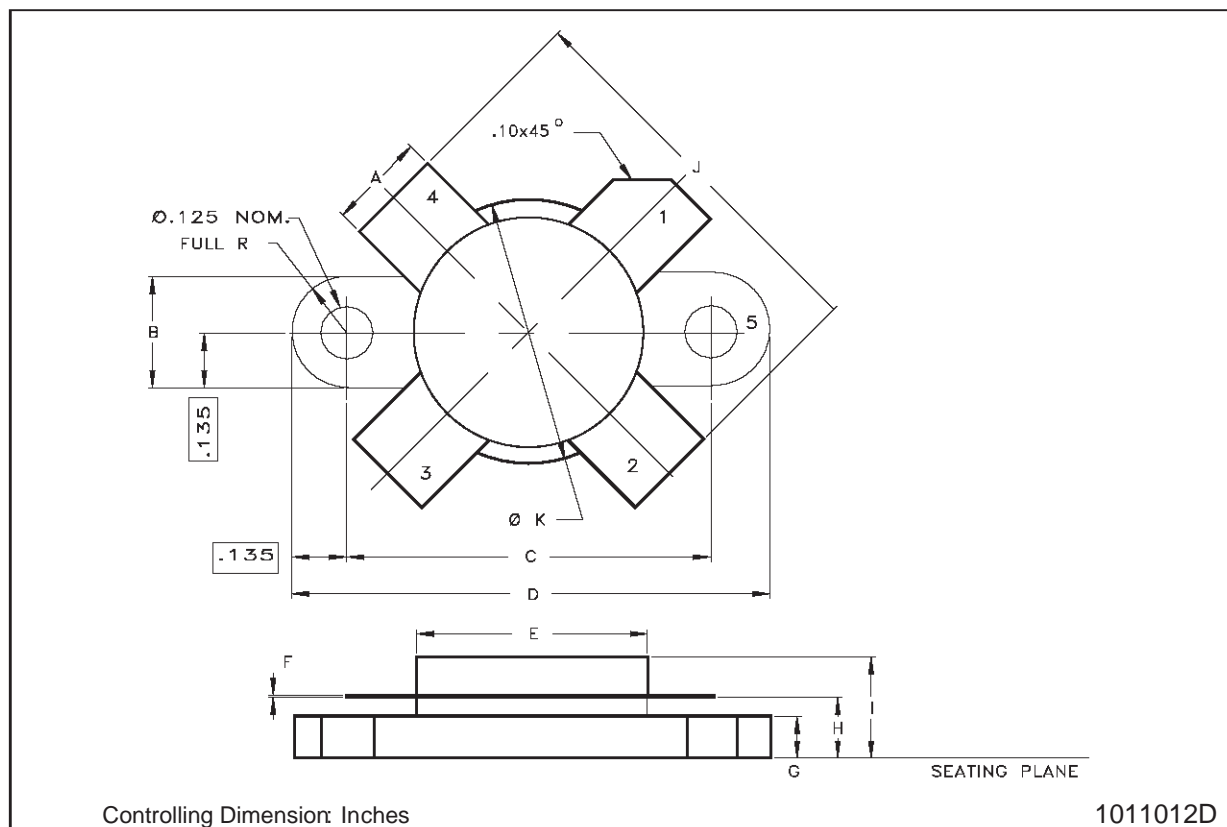

Information furnished is believed to be accurate and reliable. However, STMicroelectronics assumes no responsibility for the consequences of use of such information nor for any infringement of patents or other rights of third parties which may result from its use. No license is granted by implication or otherwise under any patent or patent rights of STMicroelectronics. Specification mentioned in this publication are subject to change without notice. This publication supersedes and replaces all information previously supplied. STMicroelectronics products are not authorized for use as critical components in life support devices or systems without express written approval of STMicroelectronics.

The ST logo is a trademark of STMicroelectronics

© 1999 STMicroelectronics – Printed in Italy – All Rights Reserved

STMicroelectronics GROUP OF COMPANIES

Australia - Brazil - China - Finland - France - Germany - Hong Kong - India - Italy - Japan - Malaysia - Malta - Morocco - Singapore - Spain - Sweden - Switzerland - United Kingdom - U.S.A.

<http://www.st.com>