



SD2931

RF POWER TRANSISTORS HF/VHF/UHF N-CHANNEL MOSFETs

TARGET DATA

- GOLD METALLIZATION
- EXCELLENT THERMAL STABILITY
- COMMON SOURCE CONFIGURATION
- POUT = 150W MIN. WITH 14 dB GAIN @175 MHz

DESCRIPTION

The SD2931 is a gold metallized N-Channel MOS field-effect RF power transistor. The SD2931 is intended for use in 50V dc large signal applications up to 230 MHz

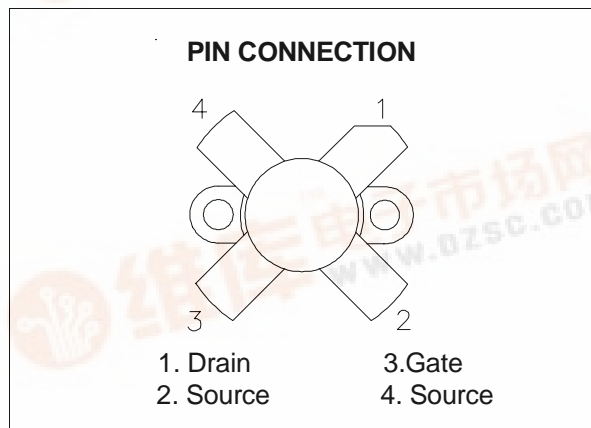
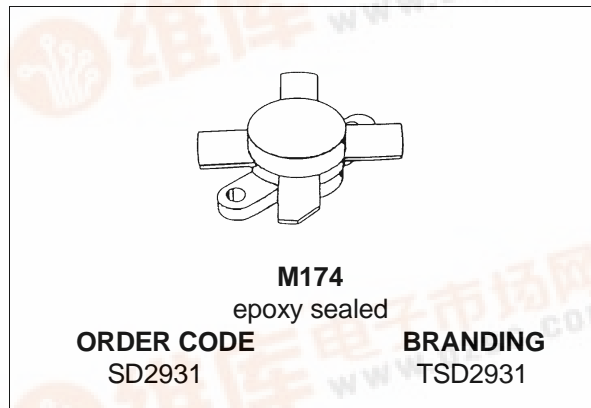

ABSOLUTE MAXIMUM RATINGS (T_{case} = 25 °C)

Symbol	Parameter	Value	Unit
V _{(BR)DSS}	Drain Source Voltage	125	V
V _{DGR}	Drain-Gate Voltage (R _{GS} = 1MΩ)	125	V
V _{GS}	Gate-Source Voltage	±20	V
I _D	Drain Current	16	A
P _{DISS}	Power Dissipation	292	W
T _j	Max. Operating Junction Temperature	200	°C
T _{STG}	Storage Temperature	-65 to 150	°C

THERMAL DATA

R _{th(j-c)}	Junction-Case Thermal Resistance	0.6	°C/W
R _{th(c-s)}	Case-Heatsink Thermal Resistance *	0.2	°C/W

* Determined using a flat aluminum or copper heatsink with thermal compound applied (Dow Corning 340 or equivalent).



SD2931

ELECTRICAL SPECIFICATION (T_{case} = 25 °C)

STATIC

Symbol	Parameter		Min.	Typ.	Max.	Unit
V _{(BR)DSS}	V _{GS} = 0V	I _{DS} = 100 mA	125			V
I _{DSS}	V _{GS} = 0V	V _{DS} = 50 V			5	mA
I _{GSS}	V _{GS} = 20V	V _{DS} = 0 V			5	μA
V _{GS(Q)}	V _{DS} = 10V	I _D = 250 mA	2		5	V
V _{DS(ON)}	V _{GS} = 10V	I _D = 10 A		2.7	3	V
G _{FS}	V _{DS} = 10V	I _D = 5 A	5			mho
C _{ISS}	V _{GS} = 0V	V _{DS} = 50 V		480		pF
C _{OSS}	V _{GS} = 0V	V _{DS} = 50 V		180		pF
C _{RSS}	V _{GS} = 0V	V _{DS} = 50 V		15		pF

DYNAMIC

Symbol	Parameter		Min.	Typ.	Max.	Unit
P _{OUT}	f = 175 MHz	V _{DD} = 50 V I _{DQ} = 250 mA	150			W
G _{PS}	f = 175 MHz	V _{DD} = 50 V P _{out} = 150 W I _{DQ} = 250 mA	14	15		dB
η _D	f = 175 MHz	V _{DD} = 50 V P _{out} = 150 W I _{DQ} = 250 mA	55	65		%
Load Mismatch	f = 175 MHz	V _{DD} = 50 V P _{out} = 150 W I _{DQ} = 250 mA All Phase Angles	10:1			VSWR

IMPEDANCE DATA

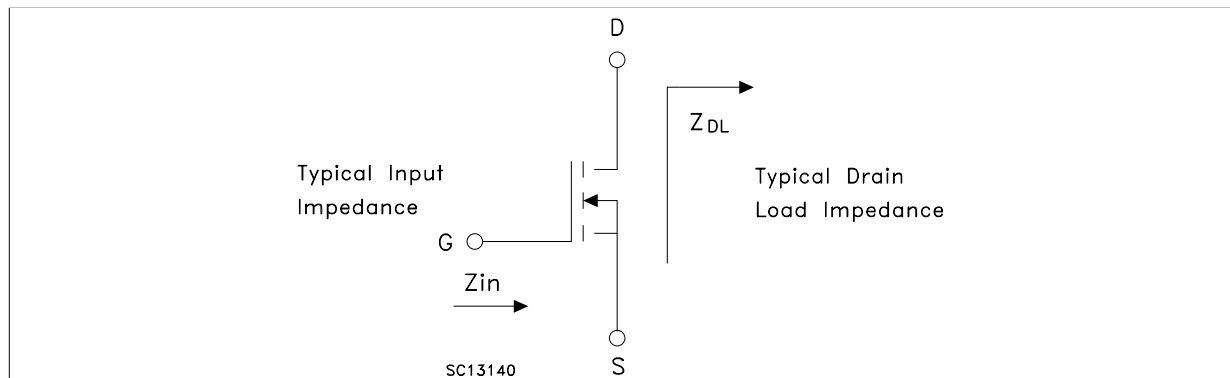

FREQ.	Z _{IN} (Ω)	Z _{DL} (Ω)
30 MHz	1.7 - j 5.7	6.8 + j 0.9
175 MHz	1.2 - j 2.0	2.0 + j 2.4

M174 (.500 DIA 4L N/HERM W/FLG) MECHANICAL DATA

DIM.	mm			inch		
	MIN.	TYP.	MAX.	MIN.	TYP.	MAX.
A	5.56		5.84	0.219		0.230
B		3.18			0.125	
C	6.22		6.48	0.245		0.255
D	18.28		18.54	0.720		0.730
E		3.18			0.125	
F	24.64		24.89	0.970		0.980
G	12.57		12.83	0.495		0.505
H	0.08		0.18	0.003		0.007
I	2.11		3.00	0.083		0.118
J	3.81		4.45	0.150		0.175
K			7.11			0.280
L	25.53		26.67	1.005		1.050
M	3.05		3.30	0.120		0.130

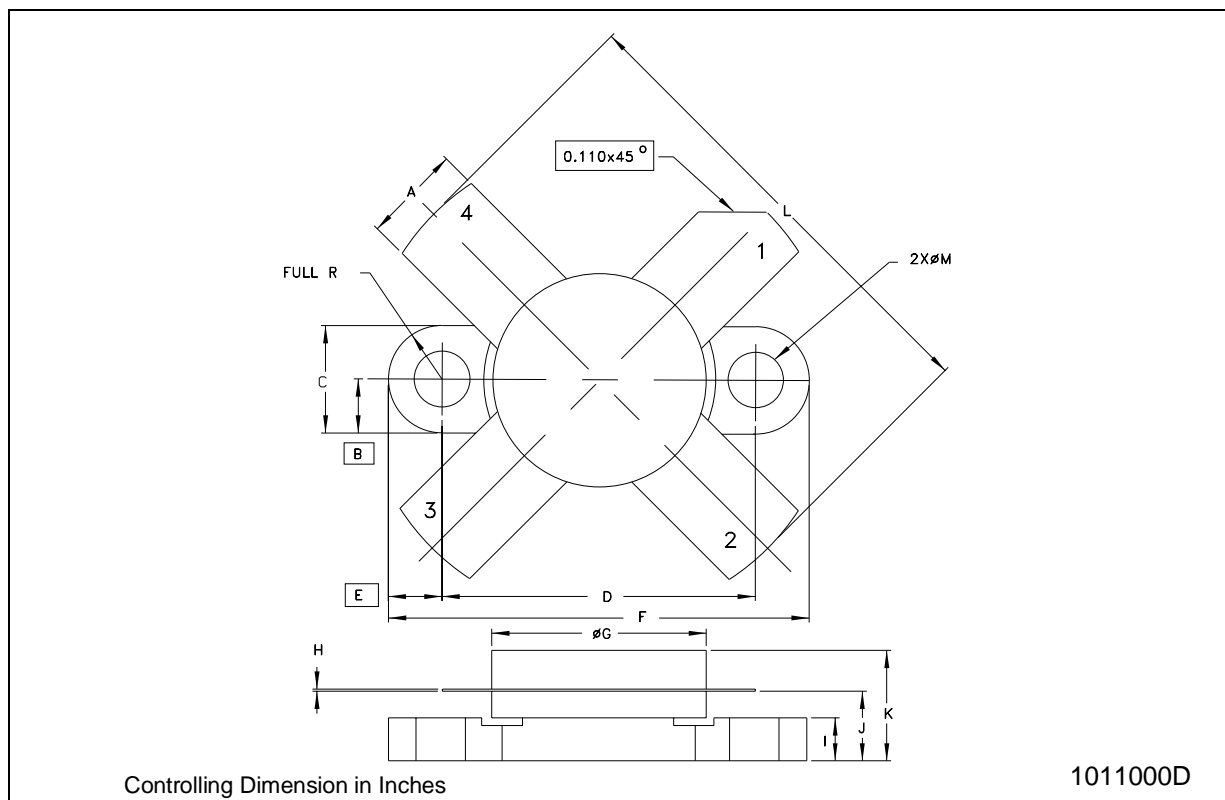

Information furnished is believed to be accurate and reliable. However, STMicroelectronics assumes no responsibility for the consequences of use of such information nor for any infringement of patents or other rights of third parties which may result from its use. No license is granted by implication or otherwise under any patent or patent rights of STMicroelectronics. Specification mentioned in this publication are subject to change without notice. This publication supersedes and replaces all information previously supplied. STMicroelectronics products are not authorized for use as critical components in life support devices or systems without express written approval of STMicroelectronics.

The ST logo is a trademark of STMicroelectronics

© 1999 STMicroelectronics – Printed in Italy – All Rights Reserved
STMicroelectronics GROUP OF COMPANIES

Australia - Brazil - China - Finland - France - Germany - Hong Kong - India - Italy - Japan - Malaysia - Malta - Morocco -
Singapore - Spain - Sweden - Switzerland - United Kingdom - U.S.A.

<http://www.st.com>