

查询SD51供应商 [捷多邦, 专业PCB打样工厂, 24小时加急出货](#)

60 Amp Schottky Rectifier SD51, SD5145

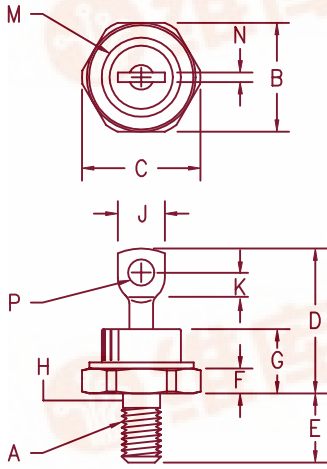

- Notes:
1. Full threads within 2 1/2 threads
 2. Standard Polarity: Stud is Cathode
Reverse Polarity: Stud is Anode

Dim.	Inches		Millimeter		Notes
	Minimum	Maximum	Minimum	Maximum	
A	---	---	---	---	1/4-28
B	.669	.688	17.00	17.47	
C	---	.794	---	20.16	
D	.750	1.00	19.05	25.40	
E	.422	.453	10.72	11.50	
F	.115	.200	2.93	5.08	
G	---	.450	---	11.43	
H	.220	.249	5.59	6.32	1
J	---	.375	---	9.52	
K	.156	---	3.97	---	
M	---	.510	---	12.95	Dia
N	---	.080	---	2.03	
P	.140	.175	3.56	4.44	Dia

DO-203AB (DO-5)

Microsemi Catalog Number	Working Peak Reverse Voltage	Repetitive Peak Reverse Voltage
SD51*	35V	35V
SD5145*	45V	45V

*Add the Suffix R for Reverse Polarity

- Schottky Barrier Rectifier
- 150°C Junction Temperature
- Guard Ring Protection
- VRRM - 35 to 45 Volts
- Reverse Energy Tested

Electrical Characteristics

Average forward current	I _{F(AV)} 60 Amps	T _C = 135°C, Square wave, R _{θJC} = 1.0°C/W 8.3 ms, half sine T _J = 175°C
Maximum surge current	I _{FSM} 800 Amps	
Max repetitive peak reverse current	I _{R(OV)} 2 Amps	f = 1 KHz, 25°C, 1 μsec Square wave
Max peak forward voltage	V _{FM} .60 Volts	I _{FM} = 60A: T _J = 125°C*
Max peak forward voltage	V _{FM} .70 Volts	I _{FM} = 60A: T _J = 25°C*
Max peak reverse current	I _{RM} 30 mA	V _R = 5.0V, T _J = 25°C
Max peak reverse current	I _{RM} 2 mA	V _{RRM} , T _J = 125°C*
Typical junction capacitance	C _J 2300 pF	V _{RRM} , T _J = 25°C

*Pulse test: Pulse width 300 μsec, Duty cycle 2%

Thermal and Mechanical Characteristics

Storage temp range	T _{STG}	-65°C to 175°C
Operating junction temp range	T _J	-65°C to 175°C
Max thermal resistance	R _{θJC}	1.0°C/W Junction to case
Typical thermal resistance (greased)	R _{θCS}	0.5°C/W Case to sink
Mounting torque		25-30 inch pounds
Weight		0.54 ounce (15.3 grams) typical

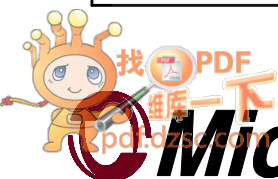

COLORADO

800 Hoyt Street
Broomfield, CO. 80020
PH: (303) 469-2161
FAX: (303) 466-3775

5-1-00 Rev.1

SD51, SD5145

Figure 1
Typical Forward Characteristics

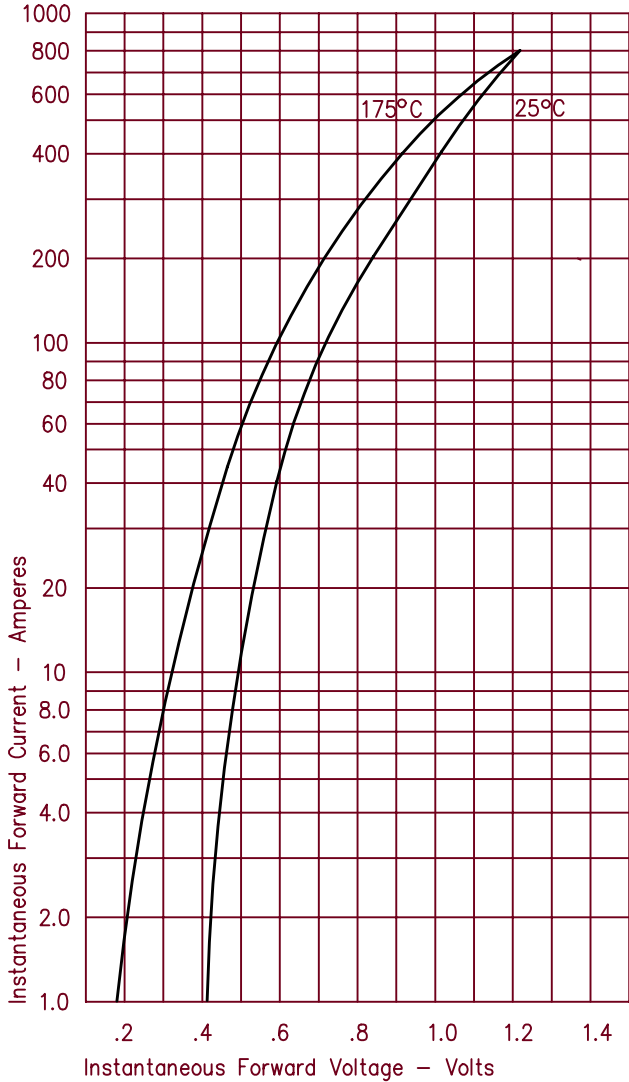

Figure 3
Typical Junction Capacitance

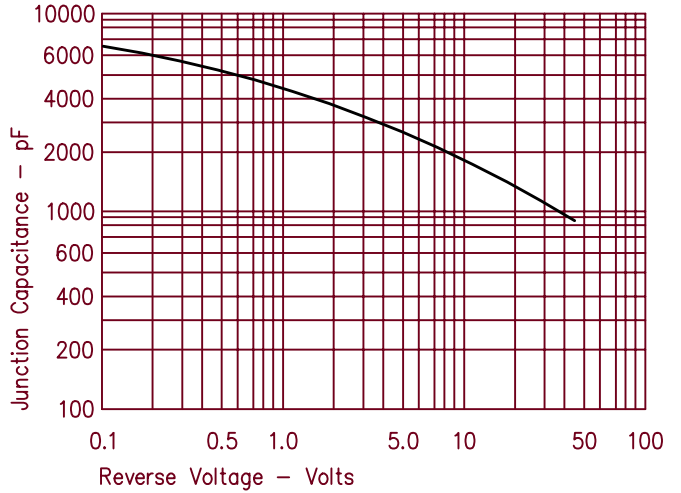

Figure 4
Forward Current Derating

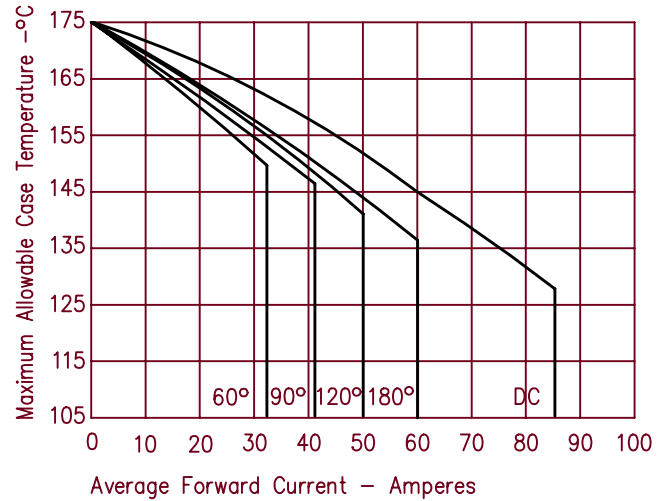

Figure 2
Typical Reverse Characteristics

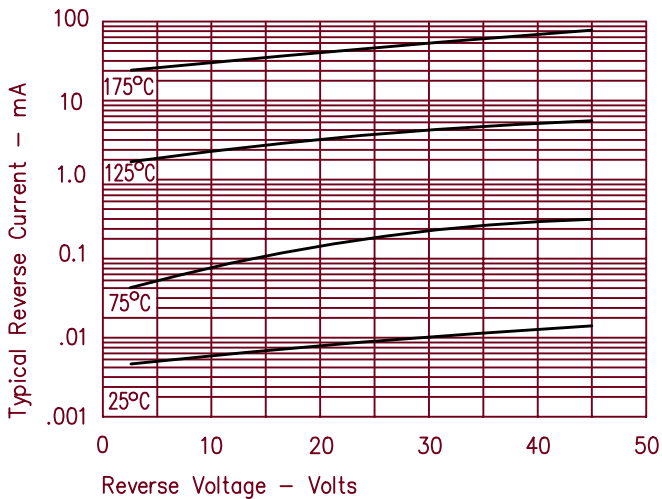

Figure 5
Maximum Forward Power Dissipation

