



SDM10M45SD

SURFACE MOUNT SCHOTTKY BARRIER DIODE

NEW PRODUCT

Features

- Fast Switching Speed
- Ultra-Small Surface Mount Package
- For General Purpose Switching Applications
- High Conductance

Mechanical Data

- Case: SOT-26, Molded Plastic
- Case material - UL Flammability Rating Classification 94V-0
- Moisture sensitivity: Level 1 per J-STD-020A
- Terminals: Solderable per MIL-STD-202, Method 208
- Polarity: See Diagram
- Marking: KLG, See Page 2
- Weight: 0.016 grams (approx.)
- Ordering Information: See Below

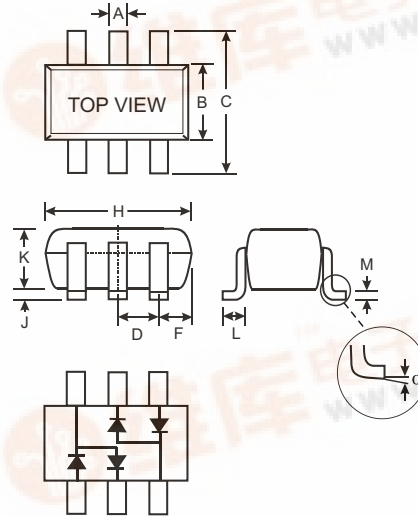

SOT-26			
Dim	Min	Max	Typ
A	0.35	0.50	0.38
B	1.50	1.70	1.60
C	2.70	3.00	2.80
D	—	—	0.95
F	—	—	0.55
H	2.90	3.10	3.00
J	0.013	0.10	0.05
K	1.00	1.30	1.10
L	0.35	0.55	0.40
M	0.10	0.20	0.15
α	0°	8°	—
All Dimensions in mm			

Maximum Ratings @ $T_A = 25^\circ\text{C}$ unless otherwise specified

Characteristic	Symbol	Value	Unit
Peak Repetitive Reverse Voltage Working Peak Reverse Voltage DC Blocking Voltage	V_{RRM} V_{RWM} V_R	45	V
RMS Reverse Voltage	$V_{R(RMS)}$	40	V
Forward Continuous Current (Note 1)	I_{FM}	100	mA
Forward Surge Current @ $t < 8.3\text{ms}$	I_{FSM}	1.0	A
Power Dissipation (Note 1)	P_d	225	mW
Thermal Resistance Junction to Ambient Air (Note 1)	$R_{\theta JA}$	444	$^\circ\text{C/W}$
Operating and Storage Temperature Range	T_j, T_{STG}	-40 to +125	$^\circ\text{C}$

Electrical Characteristics @ $T_A = 25^\circ\text{C}$ unless otherwise specified

Characteristic	Symbol	Min	Typ	Max	Unit	Test Condition
Reverse Breakdown Voltage (Note 2)	$V_{(BR)R}$	45	—	—	—	$I_R = 100\mu\text{A}$
Forward Voltage (Note 2)	V_F	—	370	450	mV	$I_F = 10\text{mA}$
Reverse Leakage Current (Note 2)	I_R	—	0.07	1.0	μA	$V_R = 10\text{V}$
Total Capacitance	C_T	—	6.0	—	pF	$V_R = 10\text{V}, f = 1.0\text{MHz}$

Ordering Information (Note 3)

Device	Packaging	Shipping
SDM10M45SD-7	SOT-26	3000/Tape & Reel

- Note:
1. Device mounted on FR-5 PCB 1.0 x 0.75 x 0.062 inch pad layout as shown on Diodes, Inc. suggested pad layout AP02001, which can be found on our website at <http://www.diodes.com/datasheets/ap02001.pdf>.
 2. Short duration pulse test to minimize self-heating effect.
 3. For packaging details, go to our website at <http://www.diodes.com/datasheets/ap02007.pdf>.



Marking Information

NEW PRODUCT

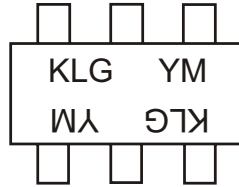

KLG = Product Type Marking Code
 YM = Date Code Marking
 Y = Year ex: P = 2003
 M = Month ex: 9 = September

Date Code Key

Year	2003	2004	2005	2006	2007	2008	2009
Code	P	R	S	T	U	V	W

Month	Jan	Feb	March	Apr	May	Jun	Jul	Aug	Sep	Oct	Nov	Dec
Code	1	2	3	4	5	6	7	8	9	O	N	D

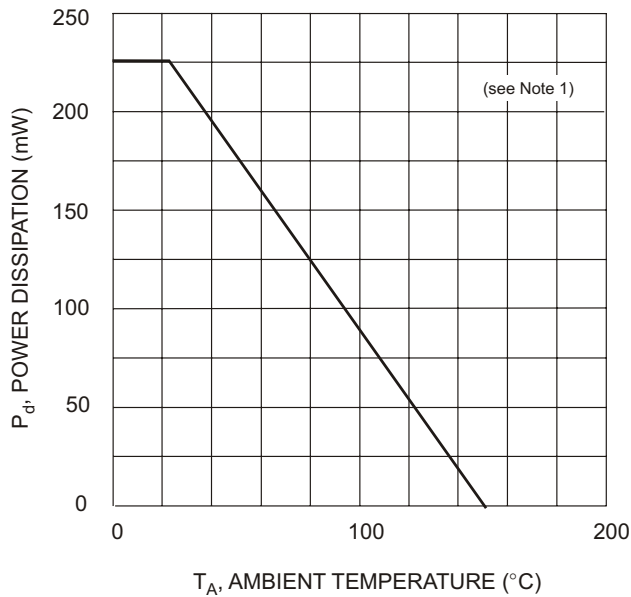

Fig. 1, Power Derating Curve

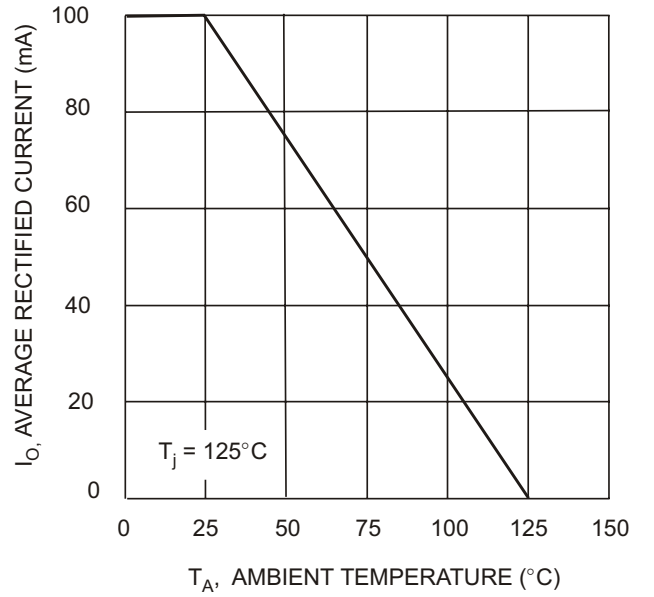

Fig. 2, Forward Current Derating Curve (Per Element)

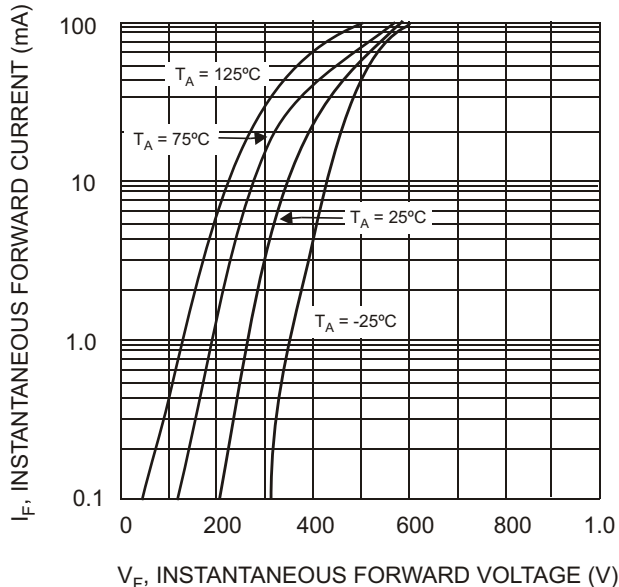

Fig. 3 Typical Forward Characteristics

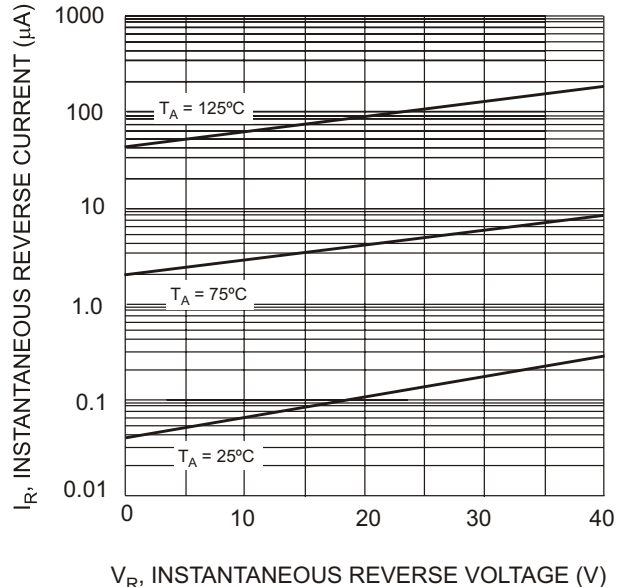

Fig. 4 Typical Reverse Characteristics

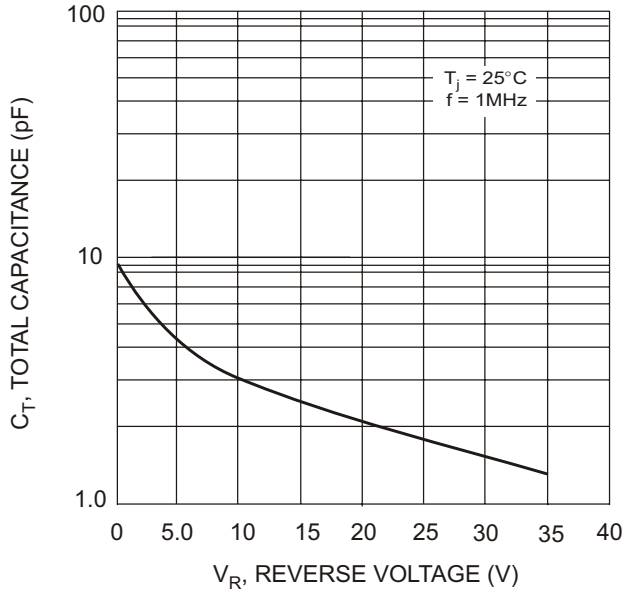

Fig. 5 Total Capacitance vs. Reverse Voltage