



SE1A THRU SE1M

SURFACE MOUNT HIGH EFFICIENCY RECTIFIER

Reverse Voltage - 50 to 1000 Volts

Forward Current - 1.0 Ampere

Features

- For surface mounted applications
- Low profile package
- Built-in strain relief
- Easy pick and place
- Ultrafast recovery times for high efficiency
- Plastic package has Underwriters Laboratory Flammability classification 94V-0
- High temperature soldering: 260°C/10 seconds at terminals

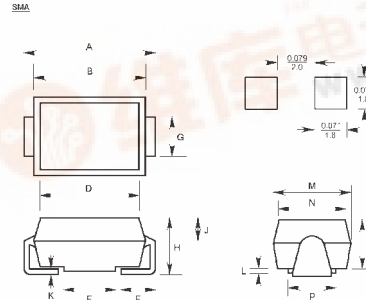

Mechanical Data

- **Case:** SMA, molded plastic
- **Terminals:** Solder plated solderable per MIL-STD-750, method 2026
- **Polarity:** Indicated by cathode band
- **Weight:** 0.004 ounce, 0.11 gram

DIM	DIMENSIONS				Note
	inches		mm		
	Min.	Max.	Min.	Max.	
A	0.216	0.226	5.48	5.74	
B	0.176	0.182	4.48	4.63	
C	0.094	0.100	2.40	2.55	
D	0.170	0.176	4.33	4.48	
E	0.039	0.055	1.00	1.40	
F	0.060	0.081	2.03	2.07	
G	0.068	0.083	1.72	2.10	
H	0.112	0.118	2.85	3.00	
J	0.057	-	1.44	-	
K	-	0.018	-	0.45	
L	0.016	-	0.40	-	
M	0.109	0.115	2.77	2.93	
N	0.105	0.107	2.67	2.73	
P	0.078	0.081	2.00	2.05	

Maximum Ratings and Electrical Characteristics

Ratings at 25°C ambient temperature unless otherwise specified.

Resistive or inductive load.

For capacitive load, derate current by 20%.

	Symbols	SE1A	SE1B	SE1D	SE1E	SE1G	SE1J	SE1K	SE1M	Units	
Maximum repetitive peak reverse voltage	V_{RRM}	50	100	200	300	400	600	800	1000	Volts	
Maximum RMS voltage	V_{RMS}	35	70	140	210	280	420	560	700	Volts	
Maximum DC blocking voltage	V_{DC}	50	100	200	300	400	600	800	1000	Volts	
Maximum average forward rectified current at $T_L=100^\circ\text{C}$	$I_{(AV)}$	1.0								Amp	
Peak forward surge current 8.3mS single half sine-wave superimposed on rated load (MIL-STD-750D 4066 method) $T_A=55^\circ\text{C}$	I_{FSM}	30.0								Amps	
Maximum instantaneous forward voltage at 1.0A	V_F	1.00			1.30		1.50	1.70		Volts	
Maximum DC reverse current at rated DC blocking voltage $T_A=25^\circ\text{C}$ $T_A=100^\circ\text{C}$	I_R	10.0 500.0								μA	
Maximum Reverse recovery time (Note 1) $T_A=25^\circ\text{C}$	T_{rr}	50					100				nS
Typical junction capacitance (Note 2)	C_J	15.0								pF	
Maximum thermal resistance (Note 3)	$R_{\theta JL}$	30.0								$^\circ\text{C/W}$	
Operating and storage temperature range	T_J, T_{STG}	-50 to +150								$^\circ\text{C}$	

Notes:

(1) Reverse recovery test conditions: $I_F=0.5\text{A}$, $I_R=1.0\text{A}$, $I_{RR}=0.25\text{A}$

(2) Measured at 1.0MHz and applied reverse voltage of 4.0 volts



RATINGS AND CHARACTERISTIC CURVES

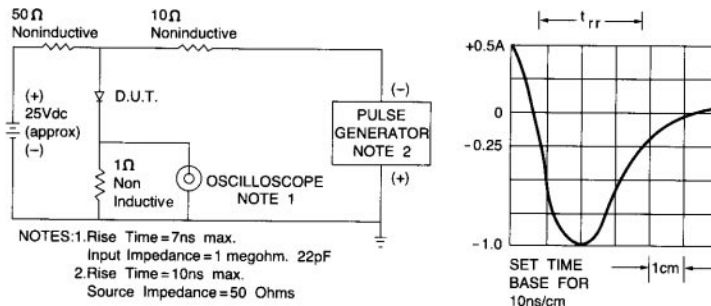

Fig. 1 – REVERSE RECOVERY TIME CHARACTERISTIC AND TEST CIRCUIT DIAGRAM

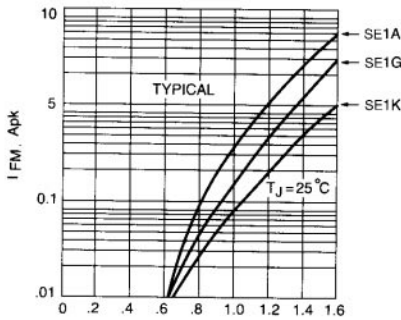

Fig. 2 – FORWARD CHARACTERISTICS

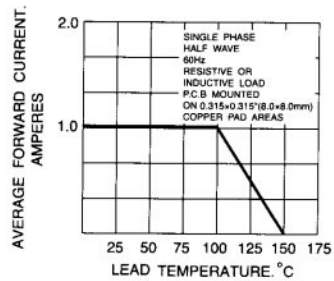

Fig. 3 – FORWARD CURRENT DERATING CURVE

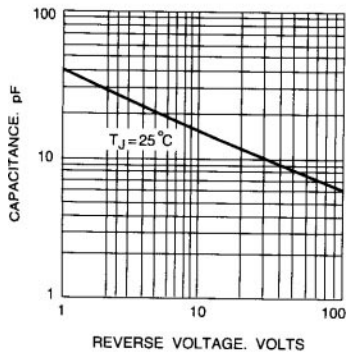

Fig. 4 – TYPICAL JUNCTION CAPACITANCE vs REVERSE VOLTAGE

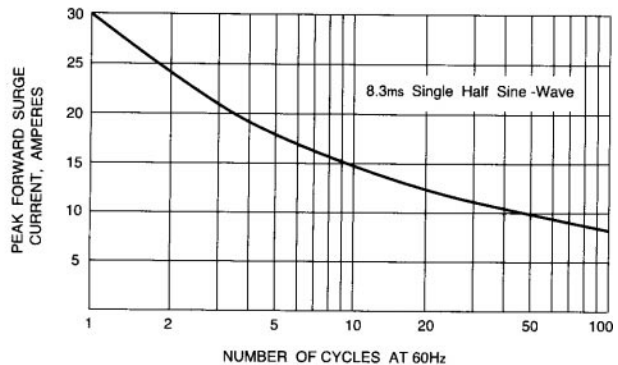

Fig. 5 – PEAK FORWARD SURGE CURRENT