



Description

The SE431 is a low voltage three terminal adjustable shunt regulator with a guaranteed thermal stability over applicable temperature ranges. The output voltage can be set to any value between V_{REF} (approximately 2.5 V) to 18V with two external resistors. This device has a typical output impedance of 0.2Ω . Active output circuitry provides a very sharp turn on characteristic, making this device excellent replacement for Zener diodes in many applications.

The SE431 is characterized for operation from 0°C to 105°C , and five package options (SOT-23-3, SOT-23-5, SOP-8, TO-92 and SOT-89) allow the designer the opportunity to select the proper package for their applications.

Block Diagram

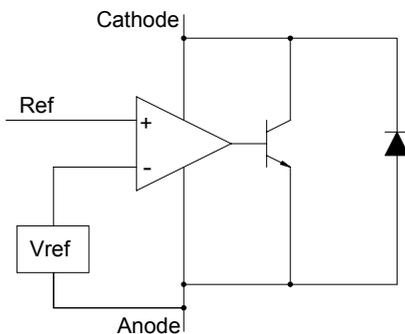

Features

- Low voltage operation (2.5V)
- Adjustable output voltage $V_0 = V_{REF}$ to 18V
- Wide operating current range $120\mu\text{A}$ to 100mA
- Low dynamic output impedance 0.2Ω (Typ.).
- Trimmed bandgap design up to $\pm 0.5\%$.
- ESD rating is 5.5KV(Per MIL-STD-883D).
- Available in Lead Free Packages.

Application

- Linear Regulators
- Adjustable Supplies
- Switching Power Supplies
- Battery Operated Computers
- Instrumentation
- Computer Disk Drives

Symbol Diagram

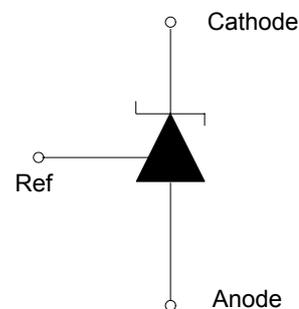



Marking Information

Package	Marking	Production Year Code	Production Week Code	Lead-Free Package
SOT-23-3 SC59-3L	SE431W	Starting with S, a bar on top of S is for production year 2001, and underlined S is for year 2002.	A-Z: 1-26 a-z: 27-52	Lead-free package is indicated by a dot on top of the week code.
SOT-23-3	S431W (SE431S)	The next character is marked on top for 2003, and underlined for 2004. The naming pattern continues		
SOT-23-5L	SE431W	with consecutive characters for later years.		
SOP-8	SE431 YYWW	YY is the year of production. 04 means the product is manufactured in year of 2004.	WW is the week of production. 26 means the product is manufactured in the 26 th week.	Lead-free package is indicated by LF after YYWW.
SOT-89	SE431 YYWW			
TO-92	SE431 YYWW			

Pin Configuration

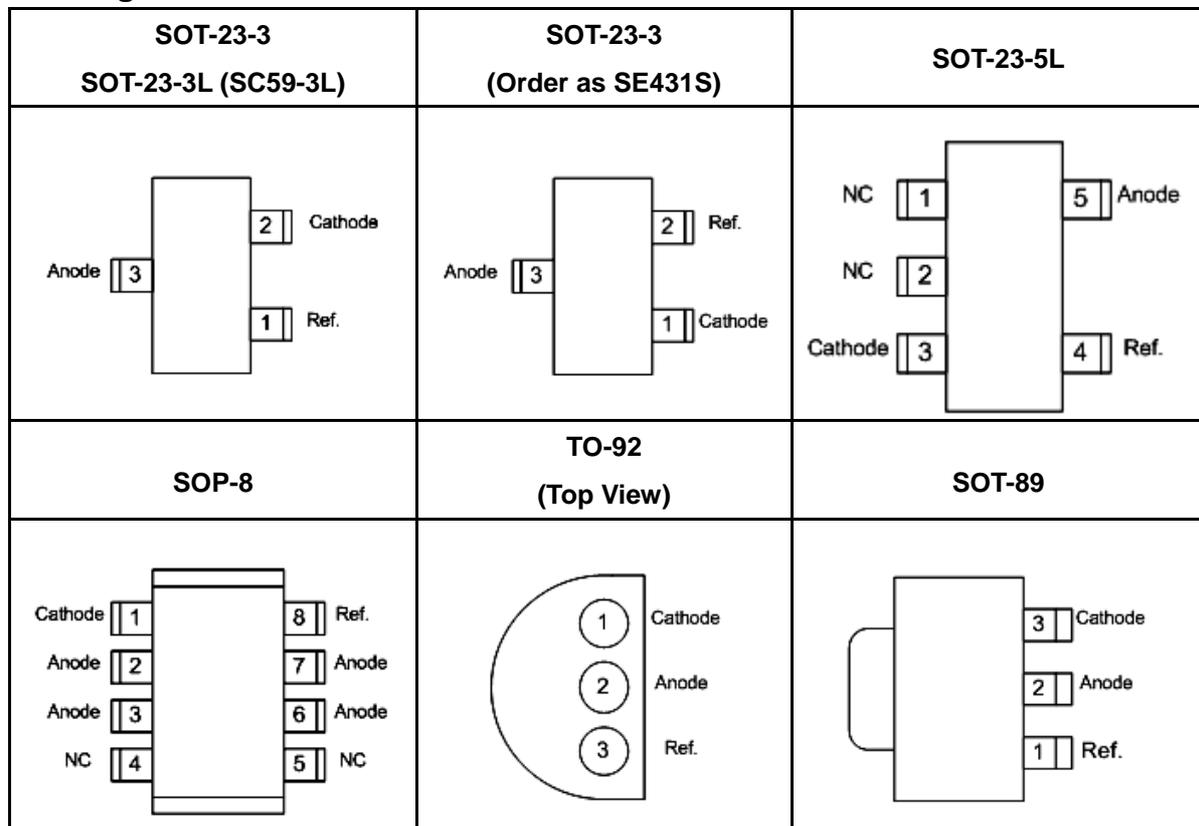



Absolute Maximum Ratings

Parameter	Symbol	Maximum	Units
Cathode Voltage	V_{KA}	18	V
Continuous Cathode Current	I_{KA}	150	mA
Reference Current	I_{REF}	10	mA
Operating Junction Temperature Range	T_J	150	°C
Storage Temperature Range	T_{STG}	-65 to 150	°C
Thermal Resistance	θ_{JA}	120 (SOT-89)	°C/W
		230 (SOT-23-3)	
		230 (SOT-23-5L)	
		150 (SOP-8)	
		220 (TO-92)	
Lead Temperature (Soldering) 10 seconds	T_{LEAD}	260	°C

Electrical Characteristics

PARAMETER	SYMBOL	TEST CIRCUIT	TEST CONDITIONS	MIN	TYP	MAX	UNIT
Reference Voltage	V_{REF}	1	$V_{KA} = V_{REF}, I_{KA} = 10mA$	2483	2495	2507	mV
				2470	2495	2520	
				2445	2495	2545	
Deviation of reference voltage over full temperature range	$V_{I(dev)}$	1	$V_{KA} = V_{REF}, I_{KA} = 10mA$ $T_A = 0^\circ C \text{ to } 105^\circ C$	--	4	25	mV
Ratio of change in reference voltage to the change in cathode voltage	$\frac{\Delta V_{REF}}{\Delta V_{KA}}$	2	$I_{KA} = 10mA,$ $\Delta V_{KA} = 10V - V_{REF}$	--	-1.4	-2.7	mV/V
Reference current	I_{REF}	2	$I_{KA} = 10mA,$ $R1=10k\Omega, R2 = \infty$	--	2	4	μA
Deviation of Reference current over full temperature range	$I_{I(dev)}$	2	$I_{KA} = 10mA, R1=10k\Omega,$ $R2 = \infty, T_A = 0^\circ C \text{ to } 105^\circ C$	--	0.4	1.2	μA
Minimum cathode current for regulation	I_{MIN}	1	$V_{KA} = V_{REF}$	--	0.2	1	mA
Off-state cathode current	I_{OFF}	3	$V_{KA} = 18V, V_{REF} = 0$	--	0.1	1	μA
Dynamic impedance	Z_{KA}	1	$I_{KA} = 1mA \text{ to } 100mA, V_{KA} = V_{REF}, f \leq 1kHz$	--	0.2	0.7	Ω



Typical Performance Characteristics

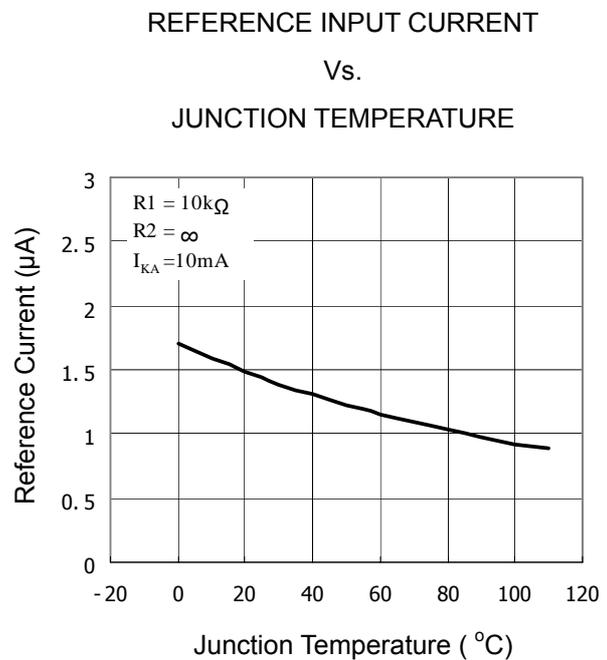
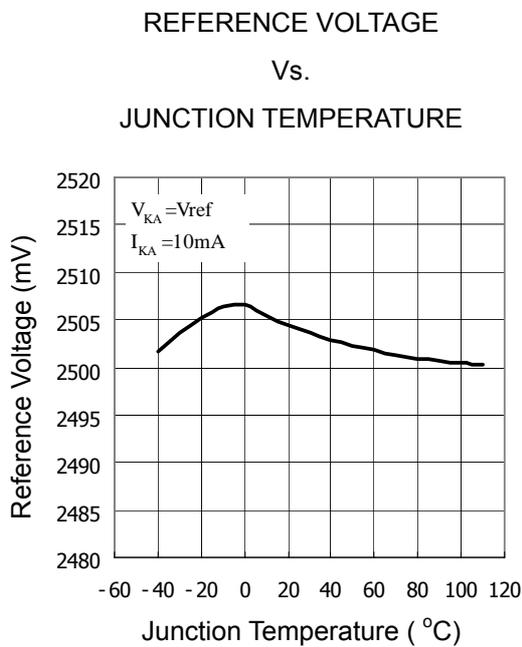
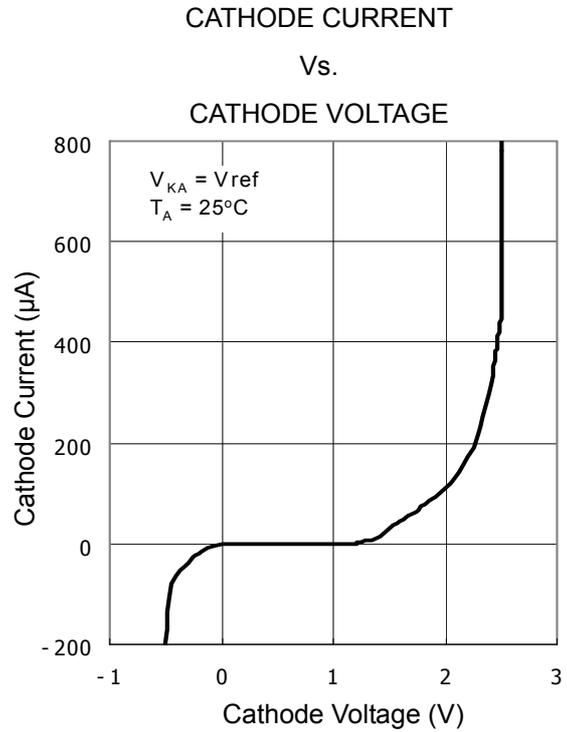
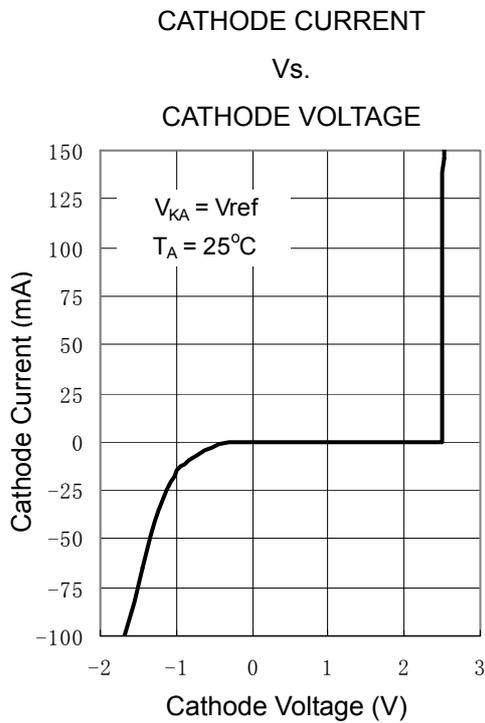



Test Circuits

<p>Test Circuit 1: $V_{KA} = V_{REF}$</p>	<p>Test Circuit 2: $V_{KA} > V_{REF}$</p>	<p>Test Circuit 3: Off State Current</p>

Application Diagram

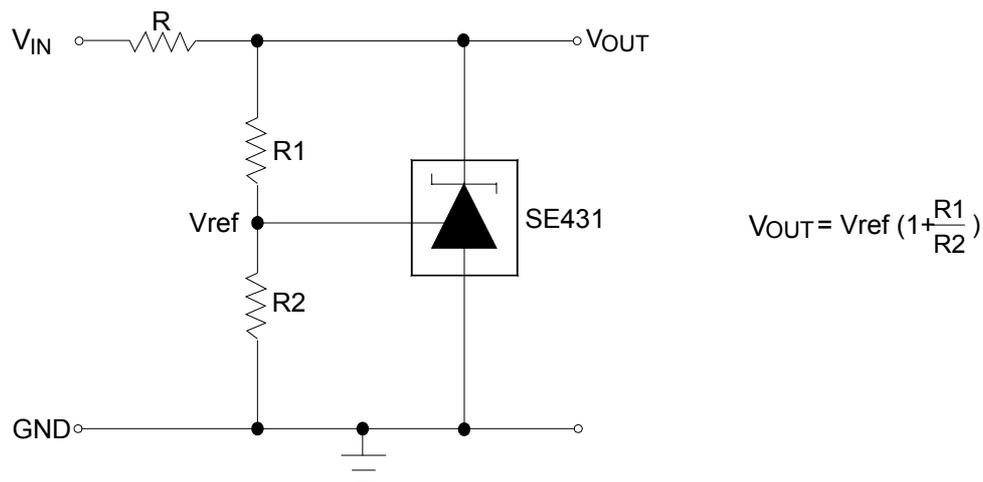

Thermal Consideration

Package	Power Rating ($T_A=25^{\circ}C$)	Power Rating ($T_A=50^{\circ}C$)	Power Rating ($T_A=70^{\circ}C$)
SOT-23-3 ($\theta_{JA}=230^{\circ}C/W$)	435mW	326mW	239mW
SOT-23-5L ($\theta_{JA}=230^{\circ}C/W$)	435mW	326mW	239mW
TO-92 ($\theta_{JA}=220^{\circ}C/W$)	455mW	341mW	250mW

1. Maximum junction temperature is 125°C
2. θ_{JA} is measured with packages mounted onboard under still-air condition with 1W power applied.
3. Power rating is calculated using $P_D = (T_J - T_A) / \theta_{JA}$, where T_J denotes junction temperature and T_A denotes ambient temperature.



OUTLINE DRAWING SOT-23-3

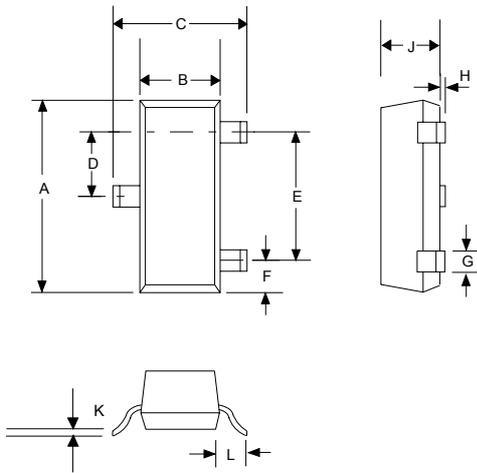

DIMENSIONS				
DIM ^N	INCHES		MM	
	MIN	MAX	MIN	MAX
A	0.110	0.120	2.80	3.04
B	0.047	0.055	1.20	1.40
C	0.083	0.104	2.10	2.64
D	0.035	0.040	0.89	1.03
E	0.070	0.080	1.78	2.05
F	0.018	0.024	0.45	0.60
G	0.015	0.020	0.37	0.51
H	0.0005	0.004	0.013	0.10
J	0.034	0.040	0.887	1.02
K	0.003	0.007	0.085	0.18
L	-	0.027	-	0.69

OUTLINE DRAWING SC59-3L (SOT-23-3L)

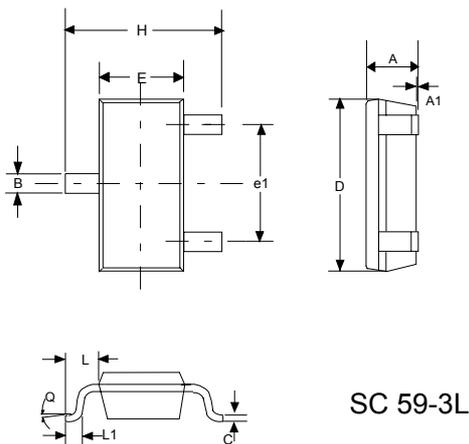

DIMENSIONS				
DIM ^N	INCHE		MM	
	MIN	MAX	MIN	MAX
A	0.035	0.043	0.90	1.10
A1	0.0004	0.005	0.01	0.13
B	0.012	0.020	0.30	0.50
C	0.004	0.008	0.09	0.20
D	0.110	0.122	2.80	3.10
H	0.098	0.122	2.50	3.10
E	0.059	0.067	1.50	1.70
e	0.037REF		0.95REF	
e1	0.075REF		1.90REF	
L1	0.008	0.022	0.20	0.55
L	0.014	0.031	0.35	0.80
Q	0°C	10°C	0°C	10°C

OUTLINE DRAWING SOT-23-5L

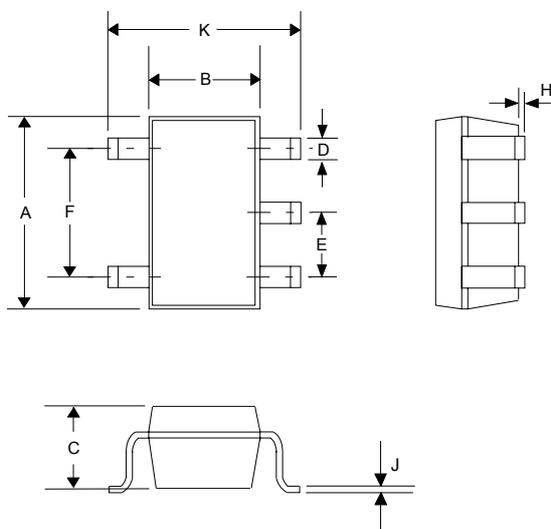

DIMENSIONS				
DIM ^N	INCHES		MM	
	MIN	MAX	MIN	MAX
A	0.110	0.120	2.80	3.05
B	0.059	0.070	1.50	1.75
C	0.036	0.051	0.90	1.30
D	0.014	0.020	0.35	0.50
E	-	0.037	-	0.95
F	-	0.075	-	1.90
H	-	0.006	-	0.15
J	0.0035	0.008	0.090	0.20
K	0.102	0.118	2.60	3.00



OUTLINE DRAWING TO-92

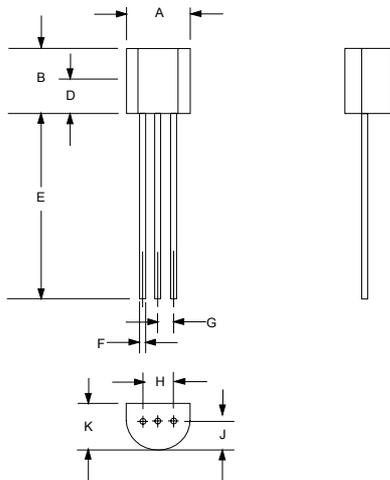

DIMENSIONS				
DIM ^N	INCHES		MM	
	MIN	MAX	MIN	MAX
A	0.175	0.205	4.445	5.207
B	0.170	0.210	4.318	5.334
E	0.500	0.610	12.70	15.50
F	0.016	0.021	0.407	0.533
G	0.045	0.055	1.143	1.397
H	0.095	0.105	2.413	2.667
J	0.080	0.105	2.032	2.667
K	0.125	0.165	3.175	4.191

OUTLINE DRAWING SOP-8

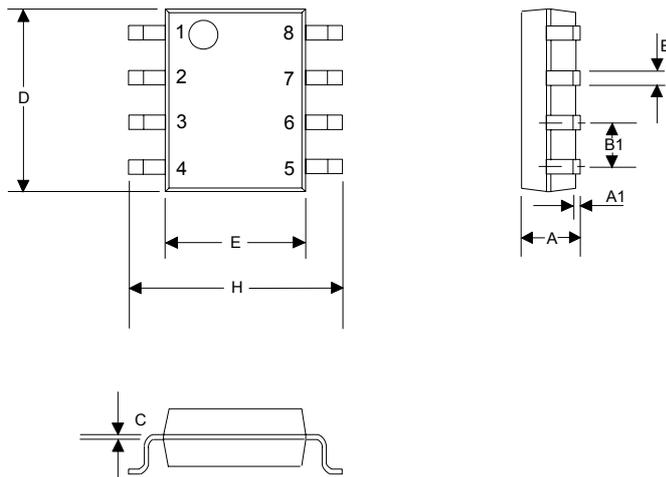

DIMENSIONS				
DIM ^N	INCHES		MM	
	MIN	MAX	MIN	MAX
A	0.0532	0.0688	1.35	1.75
A1	0.0040	0.0098	0.10	0.25
B	0.0130	0.0200	0.33	0.51
B1	0.050 BSC		1.27 BSC	
C	0.0075	0.0098	0.19	0.25
D	0.1890	0.1968	4.80	5.00
H	0.2284	0.2440	5.80	6.20
E	0.1497	0.1574	3.80	4.00

OUTLINE DRAWING SOT-89

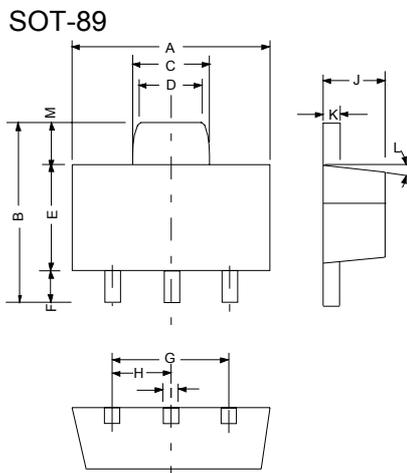

DIMENSIONS				
DIM ^N	INCHES		MM	
	MIN	MAX	MIN	MAX
A	0.173	0.181	4.400	4.600
B	0.159	0.167	4.050	4.250
C	0.067	0.075	1.700	1.900
D	0.051	0.059	1.300	1.500
E	0.094	0.102	2.400	2.600
F	0.035	0.047	0.890	1.200
G	0.118REF		3.00REF	
H	0.059REF		1.50REF	
I	0.016	0.020	0.400	0.520
J	0.055	0.063	1.400	1.600
K	0.014	0.016	0.350	0.410
L	10°TYP		10°TYP	
M	0.028REF		0.70REF	



Customer Support

Seaward Electronics Incorporated – China

Rm 1605, Building 1, International Pioneering Park, #1 Shangdi Xinxu Rd
Haidian District, Beijing 100085, China
Tel: 86-10-8289-5700/01/05
Fax: 86-10-8289-5706

Seaward Electronics Corporation – Taiwan

2F, #181, Sec. 3, Minguan East Rd,
Taipei, Taiwan R.O.C
Tel: 886-2-2712-0307
Fax: 886-2-2712-0191

Seaward Electronics Incorporated – North America

49 Showers Dr. J126
Mountain View, CA 94040, USA
Tel: 1-408-821-6600

Last Updated - 3/23/2005