

Highly-Integrated Green-Mode PWM Controller

SG6846

FEATURES

- Two-level OCP with 96mS delay time
- Peak-current-mode operation with cycle-by-cycle current limiting
- PWM frequency continuously decreasing w/ burst mode at light loads
- Low start-up current (8uA)
- Low operating current (3.7mA)
- VDD over-voltage protection (OVP)
- AC input brownout protection with hysteresis
- Programmable over-temperature protection (OTP)
- Constant power limit over universal AC input range
- Internal latch circuit for OTP, OVP, OCP
- Very few external components

APPLICATIONS

General-purpose switch mode power supplies and flyback power converters, including:

- Power adapters
- Open-frame SMPS
- Specifically fit for SMPS with surge-current output, such as for printers, scanners, motor drivers, etc.

DESCRIPTION

The highly integrated SG6846 series of PWM controllers provides several features to enhance the performance of flyback converters. To minimize standby power consumption, a proprietary green-mode function provides off-time modulation to continuously decrease

the switching frequency under light-load conditions. Under zero-load conditions, the power supply enters burst-mode. This completely shuts off PWM output. The output restarts just before the supply voltage drops below the UVLO lower limit. This green-mode function enables power supplies to easily meet international power conservation requirements.

The SG6846 is especially designed for SMPS with surge-current output. It is incorporated with a two-level OCP function. Besides the cycle-by-cycle current limiting, if the switching current is higher than 2/3 of the peak-current threshold for a delay time, over-current protection will be activated such that the SG6846 will be totally shutdown. Other protection functions include: AC input brownout protection with hysteresis, and VDD over-voltage protection. For over-temperature protection, an external NTC thermistor can be applied to sense the ambient temperature. When OCP, VDD OVP, or OTP are activated, an internal latch circuit is used to latch-off the controller. The latch will reset when the VDD supply is removed.

Other features of this controller include: Built-in synchronized slope compensation, proprietary internal compensation for constant output power limit over universal AC input range. Also, the gate output is clamped at 18V to protect the external MOSFET from over-voltage damage.

The SG6846 series controllers are available in both 8-pin DIP and SO packages.

TYPICAL APPLICATION

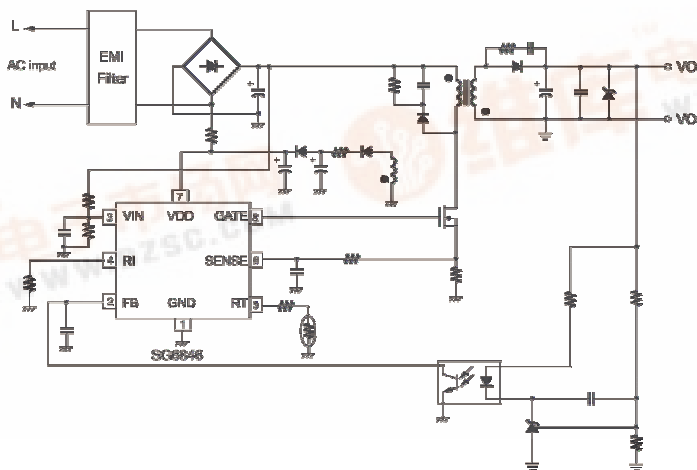

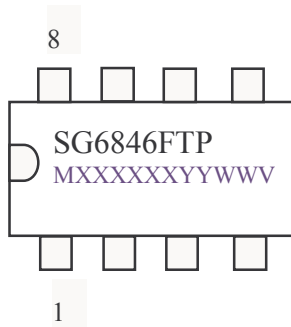
MARKING DIAGRAMS

F: L = OTP Latch
 C = Hysteresis OTP
 T: D = DIP, S = SOP
 P: Null = regular
 Z = Lead free
 M: Mask version
 XXXXXX: Wafer Lot
 YY: Year; WW: Week
 V: Assembly Location

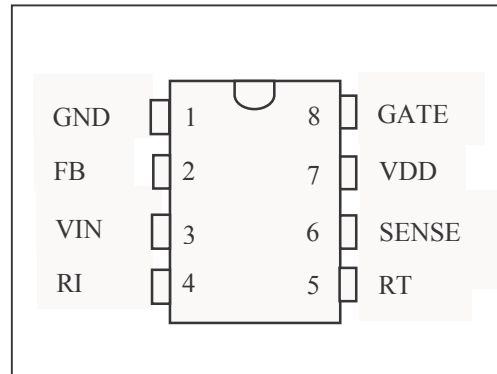
PIN CONFIGURATION

ORDERING INFORMATION

Part Number	Package	OTP Mode
SG6846LS	8-Pin SOP	Latch off
SG6846LD	8-Pin DIP	Latch off
SG6846CS	8-Pin SOP	Hysteresis
SG6846CD	8-Pin DIP	Hysteresis
SG6846LSZ	8-Pin SOP (Lead Free)	Latch off
SG6846LDZ	8-Pin DIP (Lead Free)	Latch off
SG6846CSZ	8-Pin SOP (Lead Free)	Hysteresis
SG6846CDZ	8-Pin DIP (Lead Free)	Hysteresis

PIN DESCRIPTIONS

Pin No.	Symbol	Function	Description
1	GND	Ground	Ground.
2	FB	Feedback	The signal from the external compensation circuit is fed into this pin. This FB pin and the current-sense signal from Pin 6 determine the PWM duty cycle.
3	VIN	Line-voltage Detection	Line-voltage detection. The line-voltage detection is used for brownout protection with hysteresis. Constant output power limit over universal AC input range is also achieved using this VIN signal. It is suggested to add low pass filter to filter out line ripple on bulk capacitor.
4	RI	Reference Setting	A resistor from the RI pin to ground will generate a reference current source inside SG6846. This determines the switching frequency. Increasing the resistance will reduce the switching frequency. Using a 26kΩ resistor Ri results in a 65kHz switching frequency.
5	RT	Temperature Detection	For over-temperature protection. An external NTC thermistor is connected from this pin to GND pin. The impedance of the NTC will decrease at high temperatures. Once the voltage of the RT pin drops below a threshold, PWM output will be disabled.
6	SENSE	Current Sense	Current sense. The sensed voltage is used for peak-current-mode control and cycle-by-cycle current limiting. If the switching current is higher than 2/3 of the peak-current threshold for longer than 96ms, over-current protection will be activated. This two-level OCP feature is especially suitable for SMPS with surge current output.
7	VDD	Power Supply	Power Supply. The internal protection circuit will disable PWM output when VDD over voltage.
8	GATE	Driver Output	The totem-pole output driver for the power MOSFET. A soft driving waveform is implemented for improved EMI.

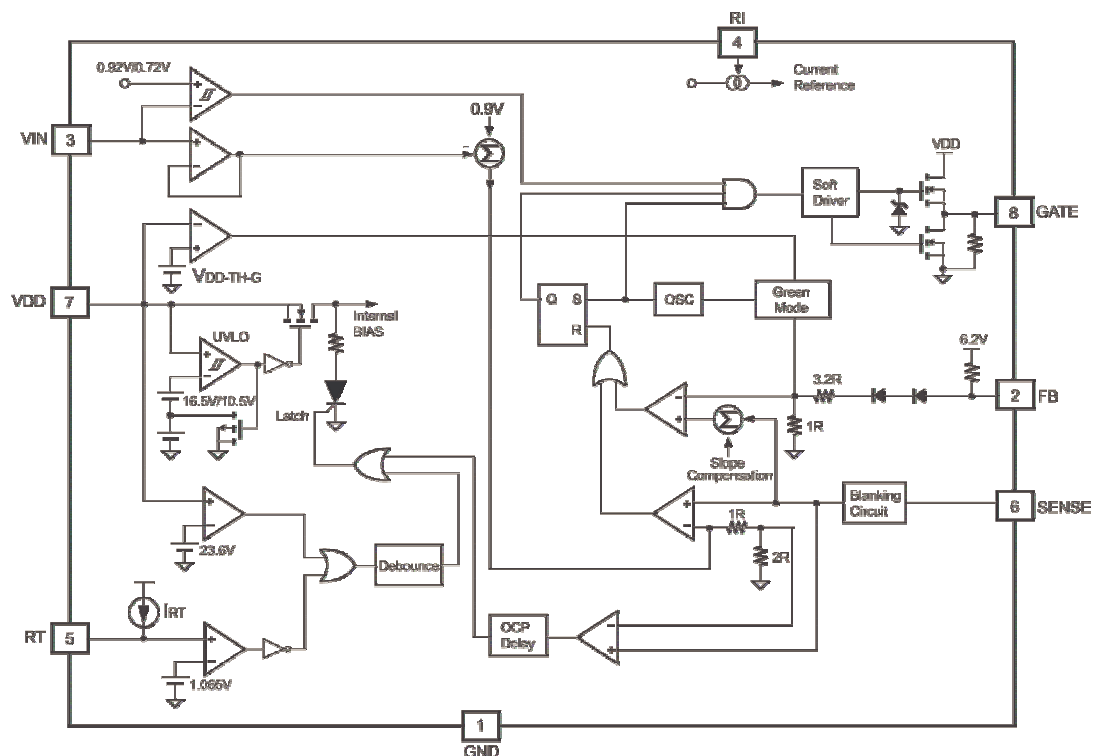
BLOCK DIAGRAM (OTP LATCH VERSION)



Highly-Integrated Green-Mode PWM Controller
SG6846
ABSOLUTE MAXIMUM RATINGS

Symbol	Parameter	Test Condition	Value	Unit
V _{DD}	Supply Voltage		25	V
V _L	Input Voltage to VIN, FB, SENSE, RT, RI Pin		-0.3 to 7V	V
P _D	Power Dissipation	at T _A < 50°C	DIP 800 SOP 400	mW
R _{θ J-C}	Thermal Resistance	Junction-Case	DIP 67.1 SOP 41.2	°C/W
T _J	Operating Ambient Temperature		-40 to 125	°C
T _{STG}	Storage Temperature Range		-65 to +150	°C
T _L	Lead Temperature (Soldering)	10 sec	DIP 260	°C
		10 sec	SOP 230	

*All voltage values, except differential voltages, are given with respect to GND pin.

*Stresses beyond those listed under "absolute maximum ratings" may cause permanent damage to the device.

RECOMMENDED OPERATING JUNCTION TEMPERATURE: -30°C ~ 85°C*

*For proper operation

ELECTRICAL CHARACTERISTICS (V_{DD} = 15V, T_A = 27°C, unless noted)
VDD Section

Symbol	Parameter	Test Condition	Min.	Typ.	Max.	Unit
V _{OP}	Continuously Operating Voltage				20	V
V _{TH-ON}	On Threshold Voltage		15.5	16.5	17.5	V
V _{TH-OFF}	Off Threshold Voltage		9.5	10.5	11.5	V
I _{DD-ST}	Start-Up Current	V _{DD} = 15V		8	30	uA
I _{DD-OP}	Operating Supply Current	GATE Open		3.7	5	mA
V _{DD-OVP}	VDD Over Voltage Protection (Latch off)		22.6	23.6	24.6	V
T _{VDD-OVP}	VDD OVP Debounce Time	RI = 26KΩ		100		usec
I _{DD-OVP}	VDD OVP Latch-up Holding Current	V _{DD} = 5V, T _A = 27°C		45		uA
V _{DD-TH-G}	VDD Low-threshold Voltage to Exit Green-OFF Mode			V _{TH(OFF)} + 1.25		V

VIN Section

Symbol	Parameter	Test Condition	Min.	Typ.	Max.	Unit
V _{IN-OFF}	PWM Turn-off Threshold Voltage		0.67	0.72	0.77	V
V _{IN-ON}	PWM Turn-on Threshold Voltage			V _{IN-OFF} + 0.2		V

Feedback Input Section

Symbol	Parameter	Test Condition	Min.	Typ.	Max.	Unit
A _V	Input-Voltage to Current-Sense Attenuation			1/4.2		V/V
Z _{FB}	Input Impedance		4	5.5	7	KΩ
V _{FB0}	FB Pin open voltage			6.2		V

Highly-Integrated Green-Mode PWM Controller

SG6846

Current Sense Section

Symbol	Parameter	Test Condition	Min.	Typ.	Max.	Unit
Z_{CS}	Input Impedance			12		$k\Omega$
T_{PD}	Delay to Output			100	200	nsec
B_{NK}	Leading Edge Blanking Time			360		nsec
$V_{TH-P} @ V_{IN}=1V$	Threshold Voltage for Current Limit	$V_{IN} = 1V, R_I = 26k\Omega$		0.83		V
$V_{TH-P} @ V_{IN}=3V$	Threshold Voltage for Current Limit	$V_{IN} = 3V, R_I = 26k\Omega$		0.70		V
$V_{TH-O} @ V_{IN}=1V$	2/3 Threshold Voltage for Current Limit	$V_{IN} = 1V, R_I = 26k\Omega$		0.61		V
$V_{TH-O} @ V_{IN}=3V$	2/3 Threshold Voltage for Current Limit	$V_{IN} = 3V, R_I = 26k\Omega$		0.51		V
$T_{DELAY-OCF}$	The Delay Time for Over-current Protection	$R_I = 26K\Omega$		96		msec

Oscillator Section

Symbol	Parameter	Test Condition	Min.	Typ.	Max.	Unit
F_{OSC}	PWM Frequency	$R_I = 26k\Omega$	60	65	70	KHz
$F_{OSC-GREEN}$	Green-mode Frequency	$R_I = 26k\Omega$	20	22.5	25	KHz
V_N	FB Pin Threshold for the Beginning of Green Mode			2.1		V
V_G	Green-OFF Mode Voltage at FB pin			1.6		V
S_G	Slope for Green-Mode Modulation	$R_I = 26k\Omega$		85		Hz/mV
F_{DV}	Frequency Variation Versus VDD Deviation	$V_{DD} = 11.5V \text{ to } 20V$			5	%
F_{DT}	Frequency Variation Versus Temp. Deviation	$T_A = -30 \text{ to } 85^\circ C$		1.5	5	%

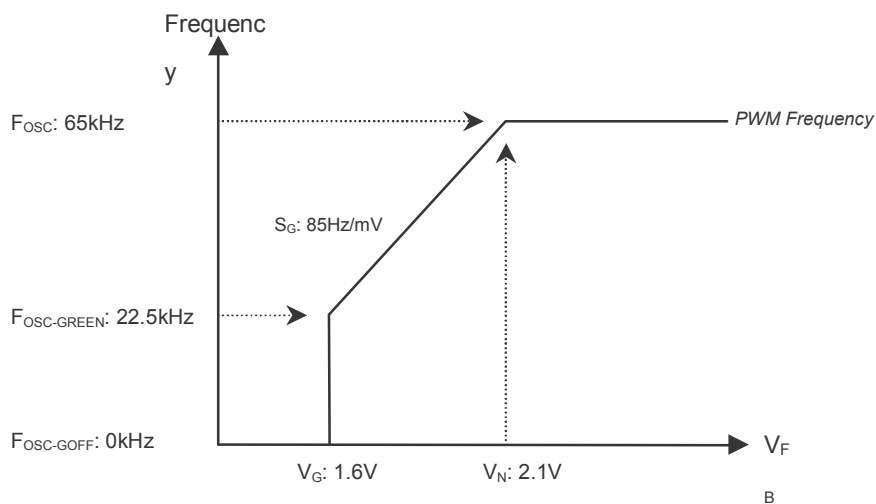

Highly-Integrated Green-Mode PWM Controller
SG6846
PWM Section

Symbol	Parameter	Test Condition	Min.	Typ.	Max.	Unit
D _{MAX}	Maximum Duty Cycle		80	85	90	%
V _{OL}	Output Voltage Low	VDD = 15V, I _o = 50mA			1.5	V
V _{OH}	Output Voltage High	VDD = 12V, I _o = 50mA	8V			V
T _R	Rising Time	VDD = 15V, CL=1nF		350		nsec
T _F	Falling Time	VDD = 15V, CL=1nF		50		nsec
V _{CLAMP}	Gate Output Clamping Voltage	VDD = 20V		18		V

Over Temperature Protection Section

Symbol	Parameter	Test Condition	Min.	Typ.	Max.	Unit
I _{RT}	Output Current of RT Pin	R _I = 26kΩ	64	70	76	uA
V _{OTP-LATCH-OFF}	Threshold Voltage for Over-Temperature Protection.		1.015	1.065	1.115	V
T _{DOTP-LATCH}	Over-Temperature Latch-Off Debounce.	R _I = 26kΩ		100		usec
V _{OTP-RESET}	OTP Release Voltage (for non-latch-off version)			V _{OTP-LATCH-OFF} + 0.1		V

RI Section

Symbol	Parameter	Test Condition	Min.	Typ.	Max.	Unit
R _I NOR	R _i Operating Range		15.5		36	kΩ
R _I MAX	Max. R _i value for Protection			216		kΩ
R _I MIN	Min. R _i value for Protection			6		kΩ

TYPICAL CHARACTERISTICS

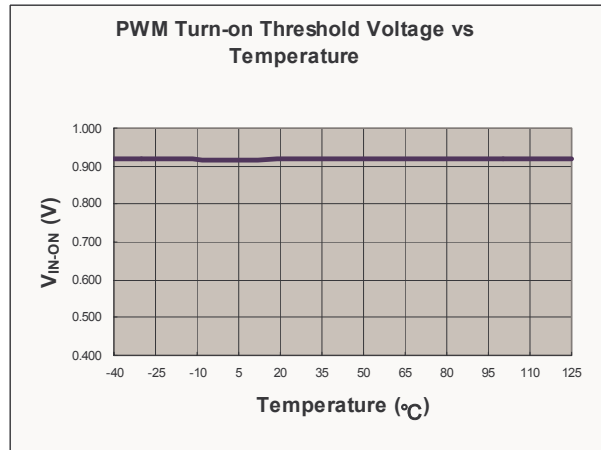
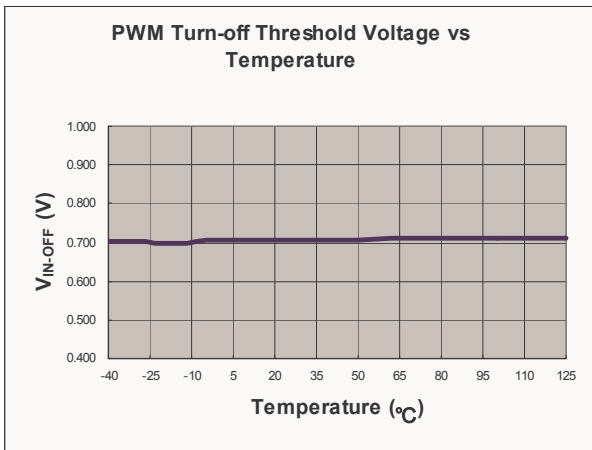
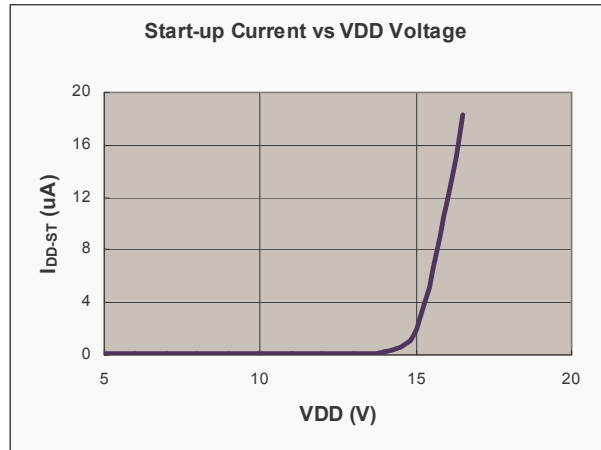
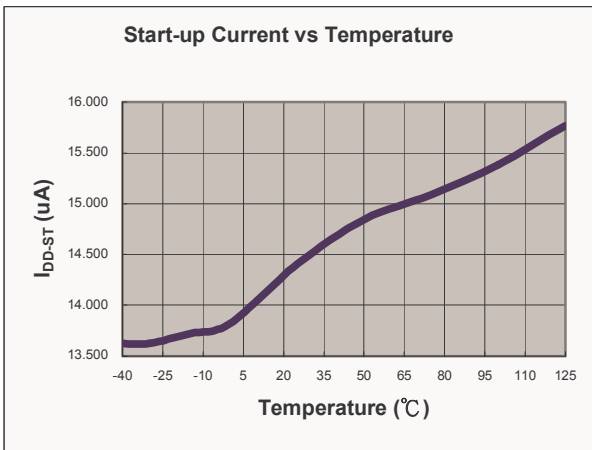
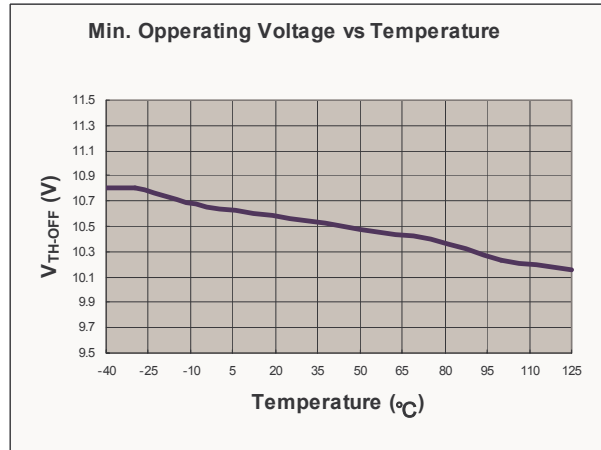
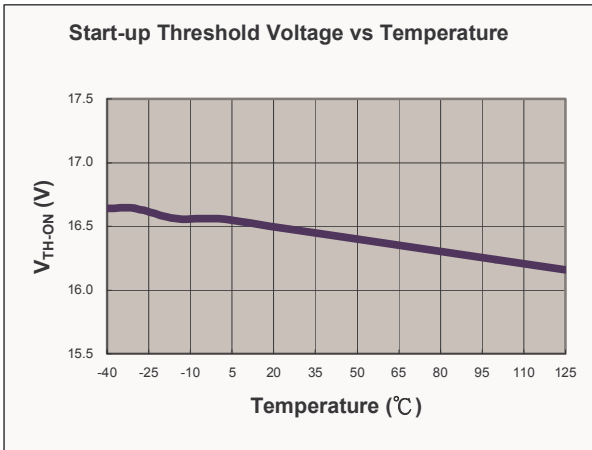

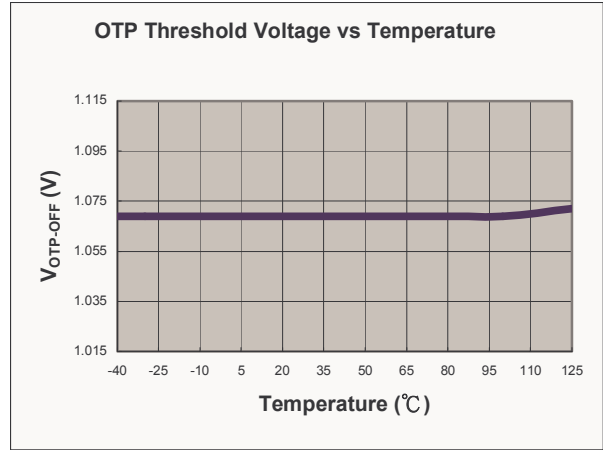
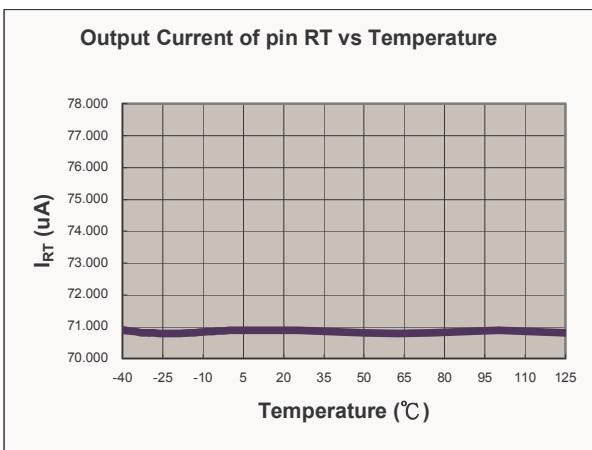
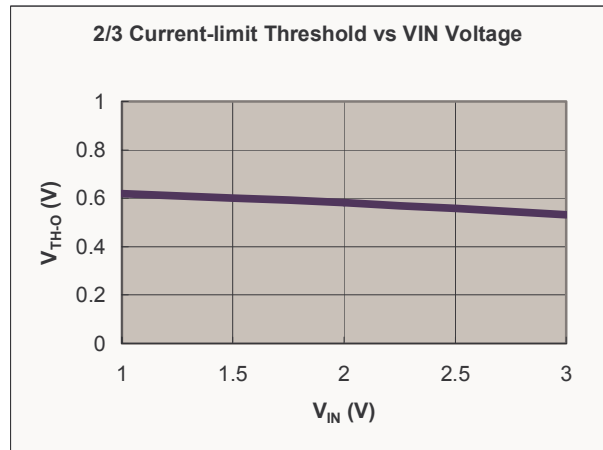
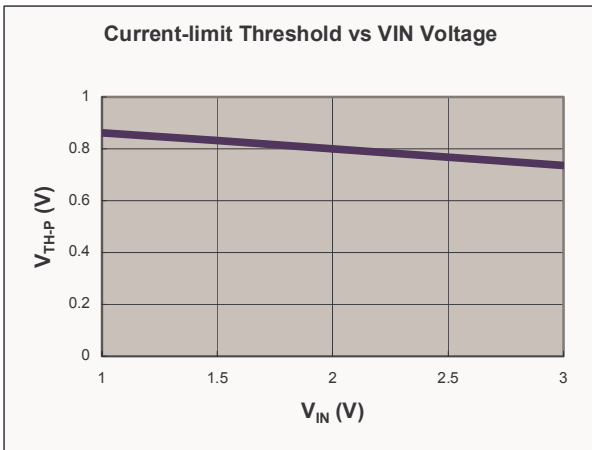
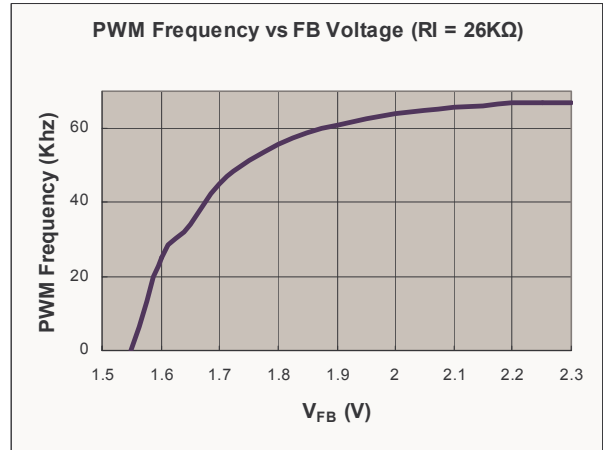
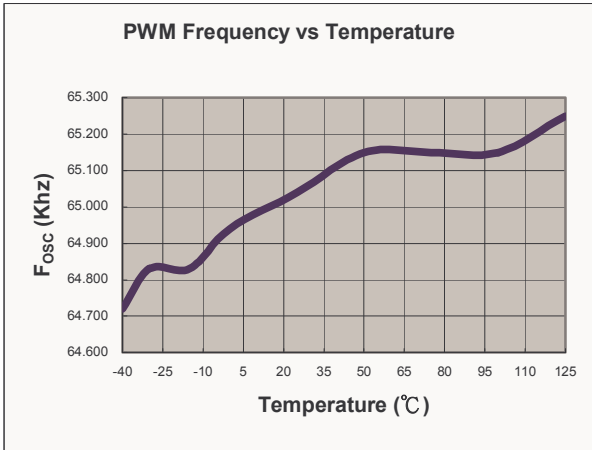

Highly-Integrated Green-Mode PWM Controller

SG6846

OPERATION DESCRIPTION

Start-up Operation

The turn-on/turn-off thresholds are fixed internally at 16.5V/10.5V. To enable the SG6846 during start-up, the hold-up capacitor must first be charged to 16.5V through the start-up resistor.

The hold-up capacitor will continue to supply VDD before energy can be delivered from the auxiliary winding of the main transformer. The VDD must not drop below 10.5V during this start-up process. This UVLO hysteresis window ensures that the hold-up capacitor can adequately supply VDD during start-up.

The typical start-up current is only 8uA. This allows a high resistance, low-wattage start-up resistor to be used, to minimize power loss. A 1.5 MΩ/0.25W, start-up resistor and a 10uF/25V VDD hold-up capacitor would be sufficient for a universal input range.

The required operating current has been reduced to 3.7mA. This enables higher efficiency and reduces the VDD hold-up capacitance requirement.

Green-Mode Operation

The proprietary green-mode function provides off-time modulation to continuously decrease the switching frequency under light-load conditions. Maximum on time is limited to provide protection against abnormal conditions. To further reduce power consumption under zero-load condition, the PWM oscillator will be completely turned off, and the power supply will enter burst-mode. After the PWM oscillator is turned off, the IC’s supply voltage VDD will drop gradually. Before the VDD voltage drops below the UVLO threshold, the PWM oscillator will be turned on again. This green-mode function dramatically reduces power consumption under light-load and zero-load conditions. Power supplies using the SG6846 can easily meet even the most restrictive international regulations regarding standby power consumption.

Oscillator Operation

A resistor connected from the RI pin to GND generates a reference current source inside the SG6846.

This current is used to determine the PWM frequency. Increasing the resistance will decrease the amplitude of the current source and reduce the PWM frequency. Using a 26kΩ resistor Ri results in a corresponding 65kHz switching frequency. The relationship between Ri and the switching frequency is:

$$f_{PWM}(kHz) = \frac{1690}{R_i (k\Omega)} \text{----- (1)}$$

If an open circuit or short circuit to ground occurs at the RI pin, the internal protection circuit will immediately shut down the controller.

Two-level Over-current Protection

The cycle-by-cycle current limiting will shut down the PWM immediately when the switching current is over the peak-current threshold. Additionally, when the switching current is higher than 2/3 of the peak-current threshold, the internal counter starts counting up. When the switching current is lower than 2/3 of the peak current threshold, the internal counter will count down. When the total accumulated counting time is more than about 96ms (Ri = 26kohm), the controller will be latched off.

This two-level OCP protection and up/down counter are especially designed for SMPS with surge current output such as those for printers, scanners, motor drivers, etc.

Constant Output Power Limit

For constant output power limit over universal input-voltage range, the peak-current threshold is adjusted by the voltage of the VIN pin. Since the VIN pin is connected to the rectified AC input line voltage through the resistive divider, a higher line voltage will generate a higher VIN voltage. The threshold voltage decreases as the VIN voltage increases, making the max. output power at high line input voltage equal to that at low line input.

Brownout Protection

Since the VIN pin is connected through a resistive divider to the rectified AC input line voltage, it can also be used for brownout protection. If the VIN voltage is less than 0.72V, the PWM output will be shut off. As the VIN

Highly-Integrated Green-Mode PWM Controller**SG6846**

voltage over 0.92V, the PWM output will be turned on again. The hysteresis window for ON/OFF is around 0.2V.

RT pin drops below 1.065V, the SG6846 will be turned off. There are two options for the protection modes, please see ORDER INFORMATION.

VDD Over-voltage Protection

VDD over-voltage protection is built in to prevent the controller from over-voltage destruction. When VDD voltage is over 23.6V, the SG6846 is latched off.

Over-temperature Protection

An external NTC thermistor can be connected from the RT pin to GND. The impedance of the NTC will decrease at high temperatures. When the voltage of the

Noise immunity

Noise from the current sense or the control signal may cause significant pulse width jitter, particularly in continuous-conduction mode. Slope compensation helps alleviate this problem. Good placement and layout practices should be followed. The designer should avoid long PCB traces and component leads. Compensation and filter components should be located near the SG6846.

PACKAGE INFORMATION

DIP-8 Outline Dimensions

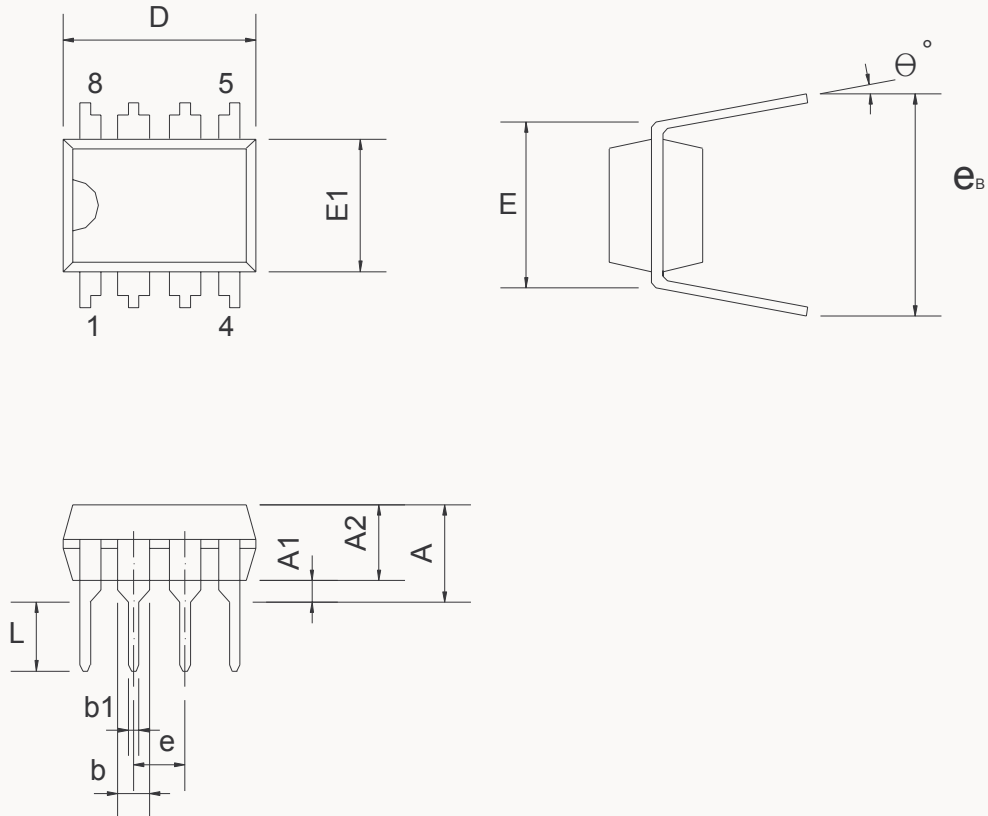

Dimension

Symbol	Millimeter			Inch		
	Min.	Typ.	Max.	Min.	Typ.	Max.
A			5.334			0.210
A1	0.381			0.015		
A2	3.175	3.302	3.429	0.125	0.130	0.135
b		1.524			0.060	
b1		0.457			0.018	
D	9.017	9.271	10.160	0.355	0.365	0.400
E		7.620			0.300	
E1	6.223	6.350	6.477	0.245	0.250	0.255
e		2.540			0.100	
L	2.921	3.302	3.810	0.115	0.130	0.150
e _B	8.509	9.017	9.525	0.335	0.355	0.375
θ°	0°	7°	15°	0°	7°	15°

SOP-8 Outline Dimensions

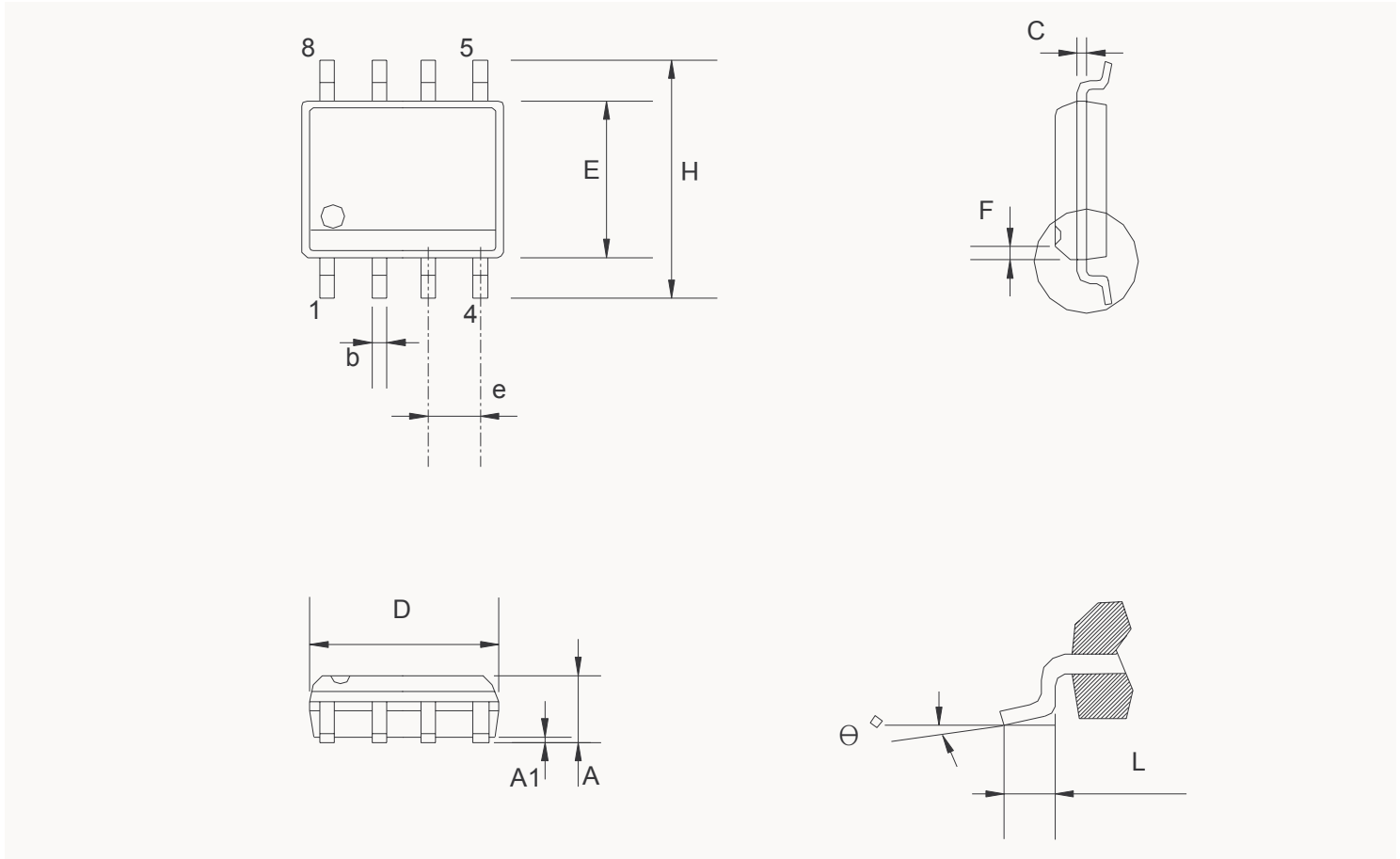

Dimension:

Symbol	Millimeter			Inch		
	Min.	Typ.	Max.	Min.	Typ.	Max.
A	1.346		1.752	0.053		0.069
A1	0.101		0.254	0.004		0.010
b		0.406			0.016	
c		0.203			0.008	
D	4.648		4.978	0.183		0.196
E	3.810		3.987	0.150		0.157
e		1.270			0.050	
F		0.381X45°			0.015X45°	
H	5.791		6.197	0.228		0.244
L	0.406		1.270	0.016		0.050
θ°	0°		8°	0°		8°

DISCLAIMERS

LIFE SUPPORT

System General's products are not designed to be used as components in devices intended to support or sustain human life. Use of System General's products in components intended for surgical implant into the body, or other applications in which failure of System General's products could create a situation where personal death or injury may occur, is not authorized without the express written approval of System General's Chief Executive Officer. System General will not be held liable for any damages or claims resulting from the use of its products in medical applications.

MILITARY

System General's products are not designed for use in military applications. Use of System General's products in military applications is not authorized without the express written approval of System General's Chief Executive Officer. System General will not be held liable for any damages or claims resulting from the use of its products in military applications.

RIGHT TO MAKE CHANGES

System General reserves the right to change this document and/or this product without notice. Customers are advised to consult their System General sales representative before ordering.