

FEATURES

- Green-Mode PWM
- Supports the “Blue Angel” Standard
- Low Start-up Current (5uA)
- Low Operating Current (2mA)
- Leading-Edge Blanking
- Constant Output Power Limit
- Universal Input
- Built-in Synchronized Slope Compensation
- Current Mode Operation
- Cycle-by-cycle Current Limiting
- Under Voltage Lockout (UVLO)
- Programmable PWM Frequency
- Gate Output Voltage Clamped at 15V
- Low Cost
- Few External Components Required
- Small SOT-26 Package

APPLICATIONS

General-purpose switching mode power supplies and flyback power converters, such as

- Battery chargers for cellular phones, cordless phones, PDAs, digital cameras, and power tools
- Power adapters for ink jet printers, video game consoles, and portable audio players
- Open-frame SMPS for TV/DVD standby and other auxiliary supplies, home appliances, and consumer electronics
- Replacements for linear transformers and RCC SMPS
- PC 5V standby power.

DESCRIPTION

This highly-integrated PWM controller provides several special enhancements designed to meet the low standby-power needs of low-power SMPS. To minimize standby power consumption, the proprietary green-mode function provides off-time modulation to linearly decrease the switching frequency under light-load conditions. This green-mode function enables the power supply to easily meet even the strictest power conservation requirements.

The BiCMOS fabrication process enables reducing the start-up current to 5uA, and the operating current to 2mA. To further improve power conservation, a large start-up resistance can be used. Built-in synchronized slope compensation ensures the stability of peak current mode control. Proprietary internal compensation provides a constant output power limit over a universal AC input range (90VAC to 264VAC). Pulse-by-pulse current limiting ensures safe operation even during short-circuits.

To protect the external power MOSFET from being damaged by supply over voltage, the SG6848’s output driver is clamped at 15V. SG6848 controllers can be used to improve the performance and reduce the production cost of power supplies. The SG6848 is the best choice for replacing linear and RCC-mode power adapters. It is available in 8-pin DIP and 6-pin SOT-26 packages.

TYPICAL APPLICATION

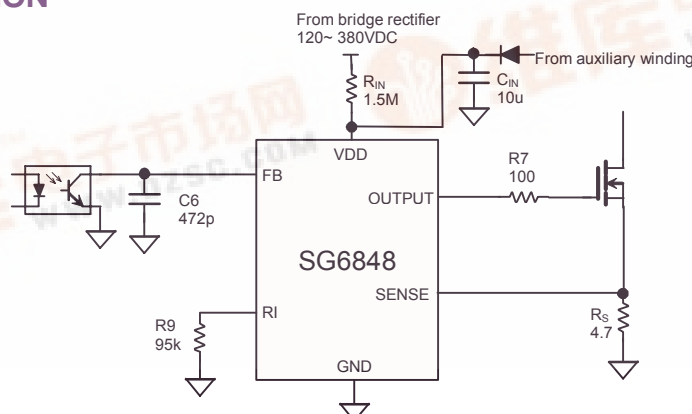

MARKING DIAGRAMS

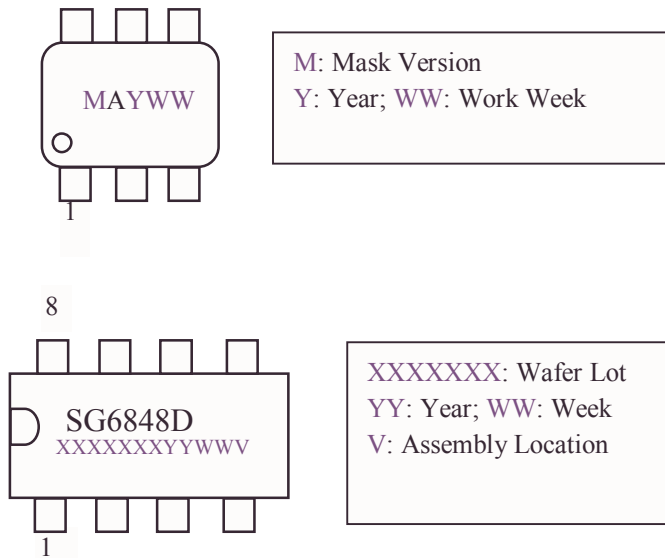

PIN CONFIGURATION

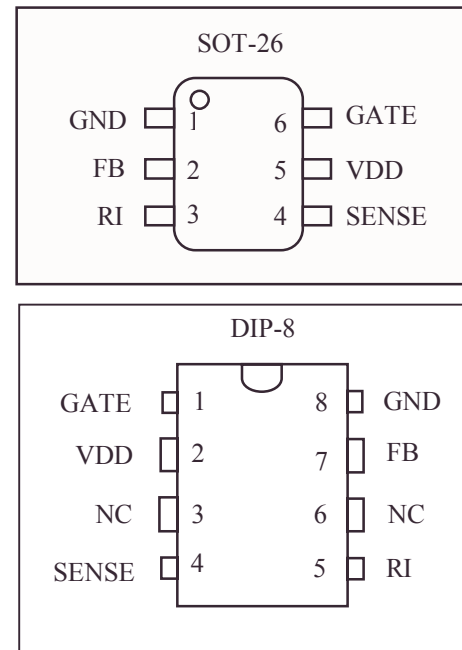

ORDERING INFORMATION

Part Number	PWM Frequency	Package
SG6848T	70kHz	6-Pin SOT-26
SG6848D	70kHz	8-pin DIP-8

PIN DESCRIPTIONS

Name	Pin No.	Type	Function
	DIP-8 / (SOT-26)		
GATE	1 / (6)	Driver Output	The totem-pole output driver for driving the power MOSFET.
VDD	2 / (5)	Supply	Power supply.
NC	3		NC pin.
SENSE	4 / (4)	Analog Input	Current sense. This pin senses the voltage across a resistor. When the voltage reaches the internal threshold, PWM output is disabled. This activates over-current protection. This pin also provides current amplitude information for current-mode control.
RI	5 / (3)	Analog Input/Output	A resistor connected from the RI pin to ground will generate a constant current source for the SG6848. This current is used to charge an internal capacitor, to determine the switching frequency. Increasing the resistance will reduce the amplitude of the current source and reduce the switching frequency. A 95kΩ resistor R _i results in a 50uA constant current I _i and a 70kHz switching frequency.
NC	6		NC pin.
FB	7 / (2)	Analog Input	Feedback. The FB pin provides the output voltage regulation signal. It provides feedback to the internal PWM comparator, so that the PWM comparator can control the duty cycle.
GND	8 / (1)	Supply	Ground.

BLOCK DIAGRAM

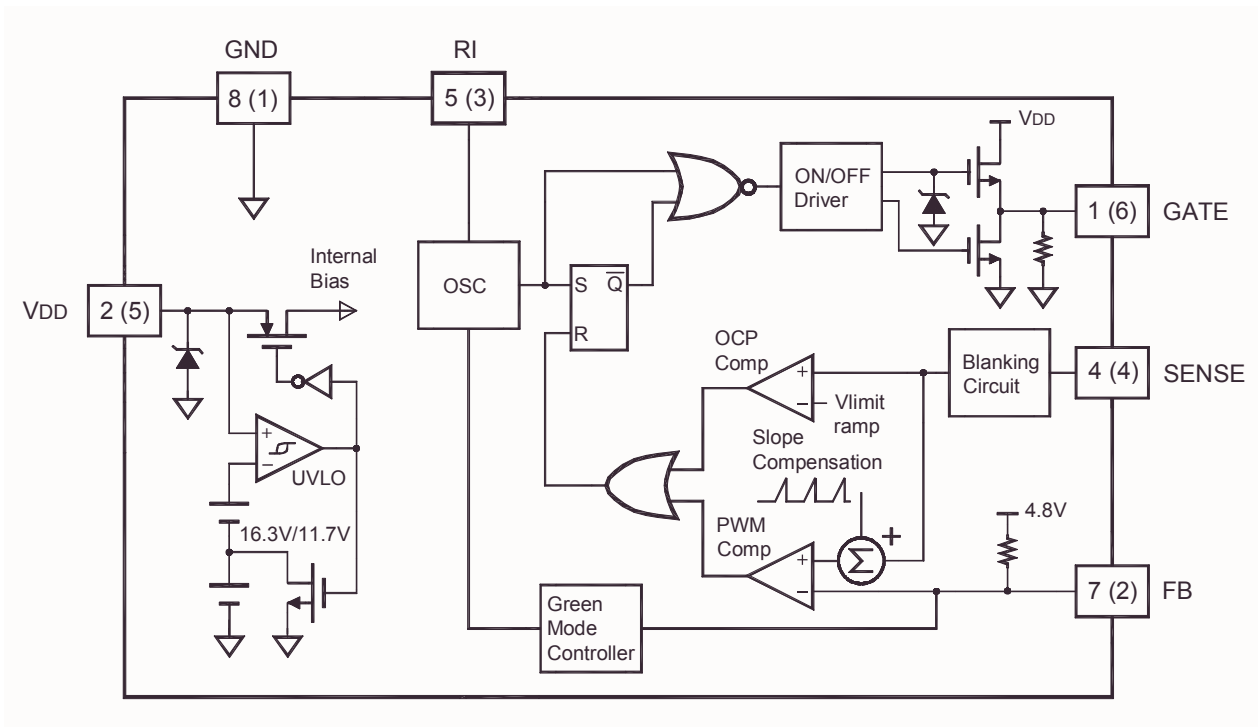

ABSOLUTE MAXIMUM RATINGS

Symbol	Parameter	Value	Unit	
V _{DD}	DC Supply Voltage *	25	V	
	Zener Clamp	26	V	
	Zener Current	10	mA	
V _{FB}	Input Voltage to FB Pin	-0.3 to 6 V	V	
V _{Sense}	Input Voltage to Sense Pin	-0.3 to 6V	V	
P _d	Power Dissipation	300	mW	
T _J	Operating Junction Temperature	150	°C	
R _{θJA}	Thermal Resistance (Junction to Air)	SOT-26	208.4	°C/W
		DIP-8	82.5	°C/W
T _{stg}	Storage Temperature Range	-55 to +150	°C	
T _L	Lead Temperature (Soldering)	20 sec SOT-26	220	°C
		10 sec DIP-8	260	°C
	ESD Capability, HBM Model	3.0	kV	
	ESD Capability, Model	300	V	

* All voltage values, except differential voltages, are given with respect to the network ground terminal.

RECOMMENDED OPERATING CONDITIONS

Symbol	Parameter	Value	Unit
V _{DD}	DC Supply Voltage	≤ 20	V
T _a	Operating Ambient Temperature	-30 to +85	°C

ELECTRICAL CHARACTERISTICS (T_A = 25°C, V_{DD}=15V)

Feedback Input Section

Symbol	Parameter	Test Condition	Min.	Typ.	Max.	Unit
I _{oz}	Zero Duty Cycle Input Current			1.3	2.0	mA
V _{op}	Open Loop Voltage			4.5		V

Current Sense Section

Symbol	Parameter	Test Condition	Min.	Typ.	Max.	Unit
Z _{cs}	Input Impedance		10			kΩ
T _{PD}	Delay to Output			150	200	nsec
V _{TH,FLT}	Current Limit Flatten Threshold Voltage			1.0		V
V _{TH,VALLEY}	Current Limit Valley Threshold Voltage		0.80	0.85	0.90	V

Oscillator Section

Symbol	Parameter	Test Condition	Min.	Typ.	Max.	Unit
F _{osc}	Frequency	R _f =95kΩ	65	70	75	kHz
F _{osc-green}	Green-Mode Frequency	R _f =95kΩ		13	15	kHz
I _g	Green-Mode FB Input Current			1.16		mA
I _n	Green-Mode Start Threshold FB Input Current I _n = 0.3mA for a Maximum Duty Cycle			1		mA
S _g	Green-Mode Modulation Slope	R _f =95kΩ		300		Hz/uA
F _{dv}	Frequency Variation versus V _{DD} Deviation	V _{DD} =12 to 20V		0.02	2	%
F _{dt}	Frequency Variation versus Temp. Deviation	T _A =-30 to 85 °C			2	%

PWM Section

Symbol	Parameter	Test Condition	Min.	Typ.	Max.	Unit
DC _(MAX)	Maximum Duty Cycle		70	75	80	%
DC _(MIN)	Minimum Duty Cycle		-	1	2	%
Bnk	Leading-Edge Blanking Time			250		nsec

Output Section

Symbol	Parameter	Test Condition	Min.	Typ.	Max.	Unit
V _{ol}	Output Voltage Low	V _{DD} =15V, I _o =20mA			1.5	V
V _{oh}	Output Voltage High	V _{DD} =15V, I _o =20mA	8			V
t _r	Rising Time	V _{DD} =15V, C _L =1nF		50	200	nsec
t _f	Falling Time	V _{DD} =15V, C _L =1nF		30	150	nsec
V _{CLAMP}	Output Clamp Voltage	V _{DD} =20V		15	17	V

Under Voltage Lockout Section

Symbol	Parameter	Test Condition	Min.	Typ.	Max.	Unit
$V_{TH(ON)}$	Start Threshold Voltage	$T_A=25^{\circ}C$	15.3	16.3	17.3	V
$V_{DD(min)}$	Min. Operating Voltage	$T_A=25^{\circ}C$	10.9	11.7	12.5	V

Total Standby Current Section

Symbol	Parameter	Test Condition	Min.	Typ.	Max.	Unit
$I_{DD\ ST}$	Start-up Current	$V_{DD}=15V$		5	30	μA
$I_{DD\ OP}$	Operating Supply Current	$V_{DD}=15V$		2	5	mA

TYPICAL CHARACTERISTICS

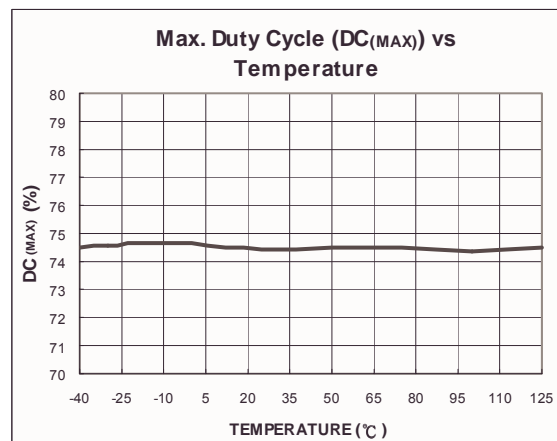
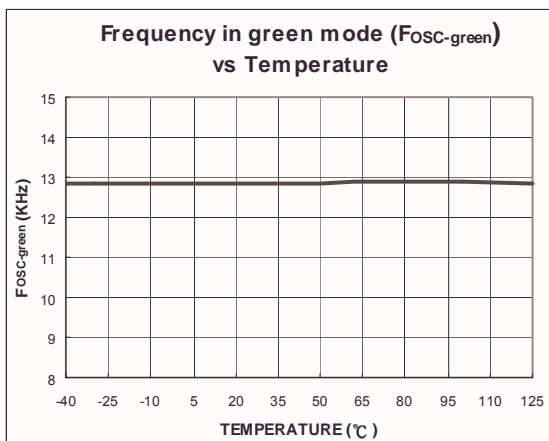
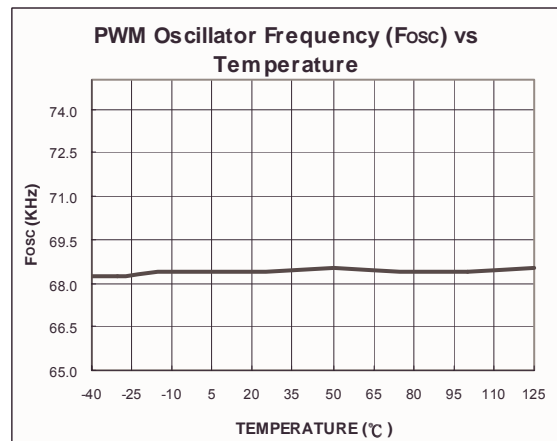
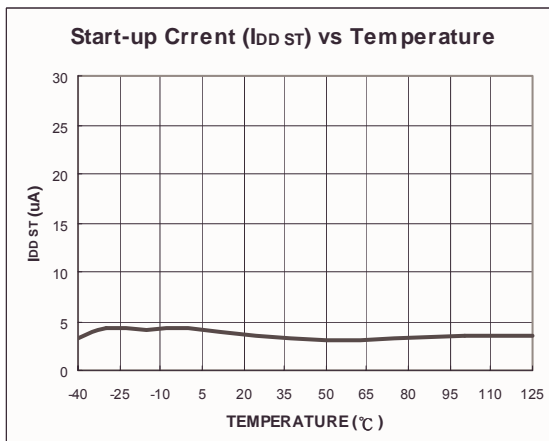
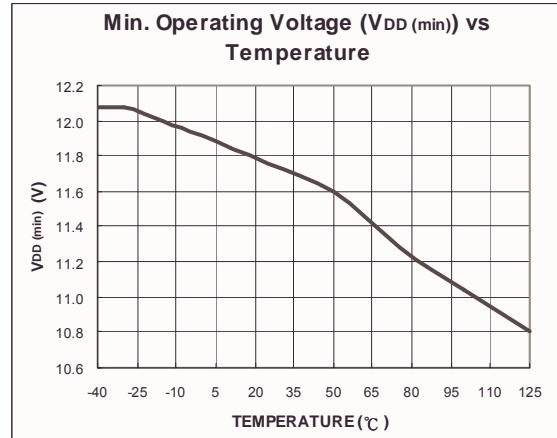
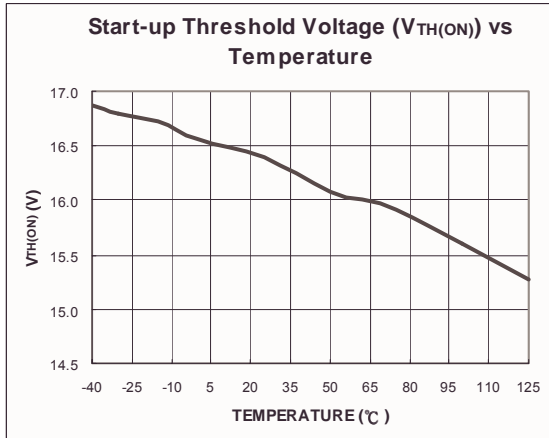

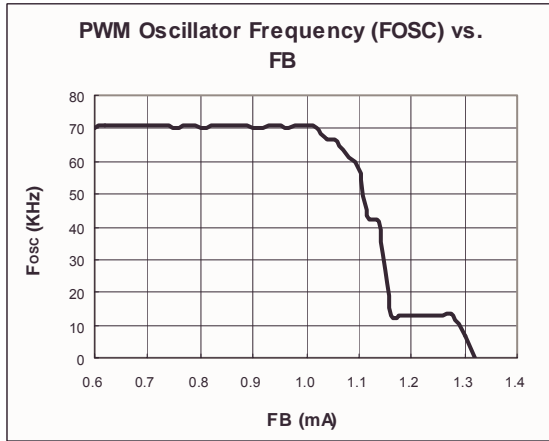

OPERATION DESCRIPTION

SG6848 devices integrate many useful designs into one controller for low-power switch-mode power supplies. The following descriptions highlight some of the features of the SG6848 series.

Start-up Current

The start-up current is only 5uA. Low start-up current allows a start-up resistor with a high resistance and a low-wattage to supply the start-up power for the controller. A 1.5 MΩ, 0.25W, start-up resistor and a 10uF/25V V_{DD} hold-up capacitor would be sufficient for an AC-to-DC power adapter with a wide input range (100V_{AC} to 240V_{AC}).

Operating Current

The operating current has been reduced to 2mA. The low operating current results in higher efficiency and reduces the V_{cc} hold-up capacitance requirement.

Green-Mode Operation

The proprietary green-mode function provides off-time modulation to linearly decrease the switching frequency under light-load conditions. On-time is limited to provide stronger protection against brownouts and other abnormal conditions. The feedback current, which is sampled from the voltage feedback loop, is taken as the reference. Once the feedback current exceeds the threshold current, the switching frequency starts to decrease. This green-mode function dramatically reduces power consumption under light-load and zero-load conditions. Power supplies using the SG6848 can easily meet even the strictest regulations regarding standby power consumption.

Oscillator Operation

A resistor connected from the RI pin to ground will generate a constant current source for the SG6848. This current is used to charge an internal capacitor. The charge-time determines the internal clock speed and the

switching frequency. Increasing the resistance will reduce the amplitude of the input current and reduce the switching frequency. A 95kΩ resistor R_i results in a 50uA constant current I_i and a 70kHz switching frequency. The relationship between R_i and the switching frequency is:

$$f_{\text{PWM}} = \frac{6650}{R_i \text{ (k}\Omega\text{)}} \text{ (kHz)}$$

The range of the oscillation frequency is designed to be within 50kHz ~ 100kHz.

Leading-Edge Blanking

Each time the power MOSFET is switched on, a turn-on spike will inevitably occur at the sense-resistor. To avoid premature termination of the switching pulse, a 250 nsec leading-edge blanking time is built in. Conventional RC filtering can therefore be omitted. During this blanking period, the current-limit comparator is disabled and it cannot switch off the gate driver.

Constant Output Power Limit

When the SENSE voltage across the sense resistor R_s reaches the threshold voltage (around 1.0V), the output GATE drive will be turned off following a short propagation delay t_D. This propagation delay will introduce an additional current proportional to t_D*V_{in}/L_p. The propagation delay is nearly constant regardless of the input line voltage V_{IN}. Higher input line voltages will result in larger additional currents. At high input line voltages, the output power limit will be higher than at low input line voltages.

To compensate for this output power limit variation across a wide AC input range, the threshold voltage is adjusted by adding a positive ramp. This ramp signal rises from 0.85V to 1.0V, and then flattens out at 1.0V. A smaller threshold voltage forces the output GATE drive to terminate earlier. This reduces the total PWM turn-on time and makes the output power equal to that of low line input. This proprietary internal compensation ensures a constant output power limit for a wide AC input voltage range (90VAC to 264VAC).

Under Voltage Lockout (UVLO)

The turn-on and turn-off thresholds of the SG6848 are fixed internally at 16.3V/11.7V. During start-up, the hold-up capacitor must be charged to 16.3V through the start-up resistor, so that the SG6848 will be enabled. The hold-up capacitor will continue to supply V_{DD} until power can be delivered from the auxiliary winding of the main transformer. V_{DD} must not drop below 11.7V during this start-up process. This UVLO hysteresis window ensures that hold-up capacitor will be adequate to supply V_{DD} during start-up.

Gate Output

The SG6848 BiCMOS output stage is a fast totem pole gate driver. Cross conduction has been avoided to minimize heat dissipation, increase efficiency, and enhance reliability. The output driver is clamped by an internal 15V Zener diode in order to protect power MOSFET transistors against undesired over-voltage gate signals.

Built-in Slope Compensation

The sensed voltage across the current sense resistor is used for current mode control and pulse-by-pulse current limiting. Built-in slope compensation will improve stability and prevent sub-harmonic oscillations due to peak-current mode control. The SG6848 has a synchronized, positively-sloped ramp built-in at each switching cycle. The slope of the ramp is:

$$\frac{0.33 \times Duty}{Duty(max)}$$

Noise Immunity

Noise from the current sense or the control signal can cause significant pulse width jitter, particularly in continuous-conduction mode. While slope compensation helps alleviate these problems, further precautions should still be taken. Good placement and layout practices should be followed. Avoiding long PCB traces and component leads, locating compensation and filter components near the SG6848, and increasing the power MOS gate resistance is advised.

REFERENCE CIRCUIT

Circuit

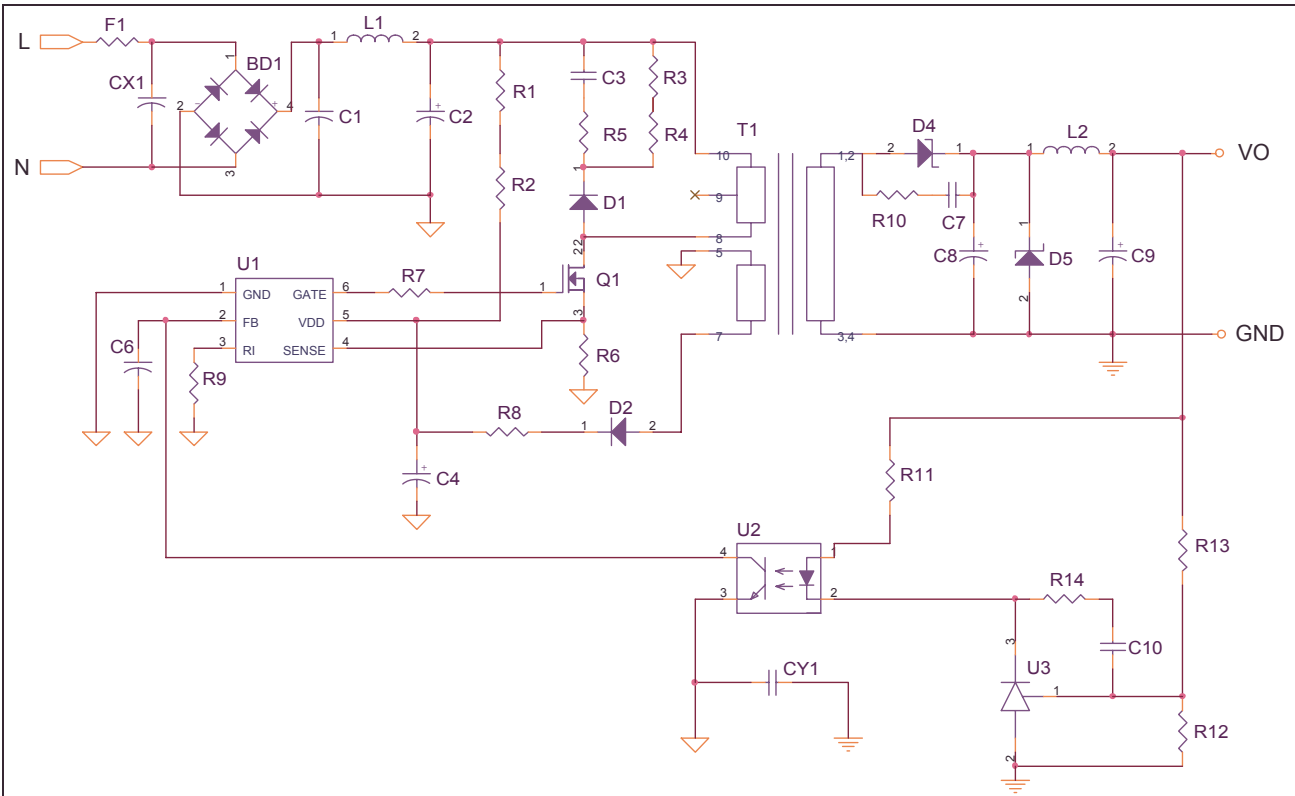

BOM

Reference	Component	Reference	Component
BD1	BD 1A/500V	L2	10uH 6mm
CX1 (Optional)	YC 472P/400V (Y1)	Q1	MOSFET 1A/600V
CY1 (Optional)	YC 102P/400V (Y1)	R1,R2	R 750KΩ 1206
C2	EC 10uF/400V 105°C	R4,R3	R 47KΩ 1206
C1	CC 103P/500V	R5	R 47Ω 1206
C3	CC 1000P/500V	R6	R 4.7Ω 1206
C4	EC 10u/50V	R7	R 100Ω 0805
C6	CC 472P 0805	R8	R 10Ω 1206
C7 (Optional)	CC 102P/100V 1206	R10 (Optional)	R 10Ω 1206
C8	EC 470u/10V 105°C	R9	R 100KΩ 0805
C9	EC 220u/10V 105°C	R11	R 100Ω 1/8W
C10	CC 222P 0805	R12	R 33KΩ 0805
D1	Diode FRI07	R13	R 33KΩ 1/8W
D2	Diode FR102	R14	R 4.7KΩ 0805
D4	Diode SB360	T1	EE-16
D5 (Optional)	ZD 6.8V 0.5W	U1	IC SG6848 (Green PWM IC)
F1	R 1Ω/0.5W	U2	PC817
L1	20mH 6*8mm	U3	TL431

PACKAGE INFORMATION

8 PINS -- DIP (D)

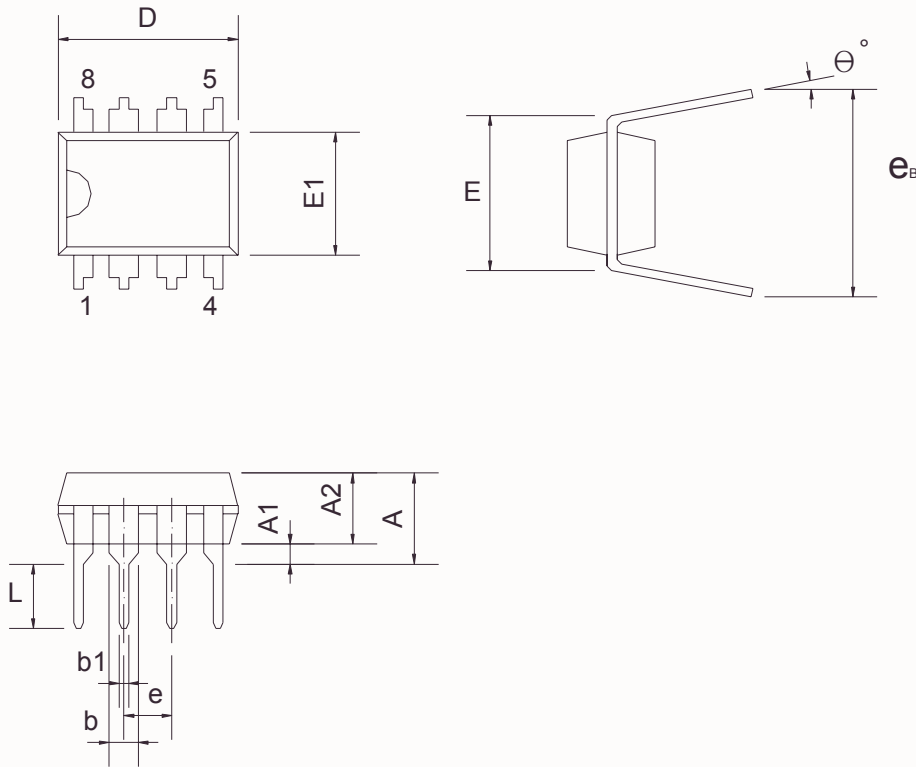

Dimensions

Symbol	Millimeters			Inches		
	Min.	Typ.	Max.	Min.	Typ.	Max.
A			5.334			0.210
A1	0.381			0.015		
A2	3.175	3.302	3.429	0.125	0.130	0.135
b		1.524			0.060	
b1		0.457			0.018	
D	9.017	9.271	10.160	0.355	0.365	0.400
E		7.620			0.300	
E1	6.223	6.350	6.477	0.245	0.250	0.255
e		2.540			0.100	
L	2.921	3.302	3.810	0.115	0.130	0.150
e _B	8.509	9.017	9.525	0.335	0.355	0.375
θ°	0°	7°	15°	0°	7°	15°

SOT-26 (S)

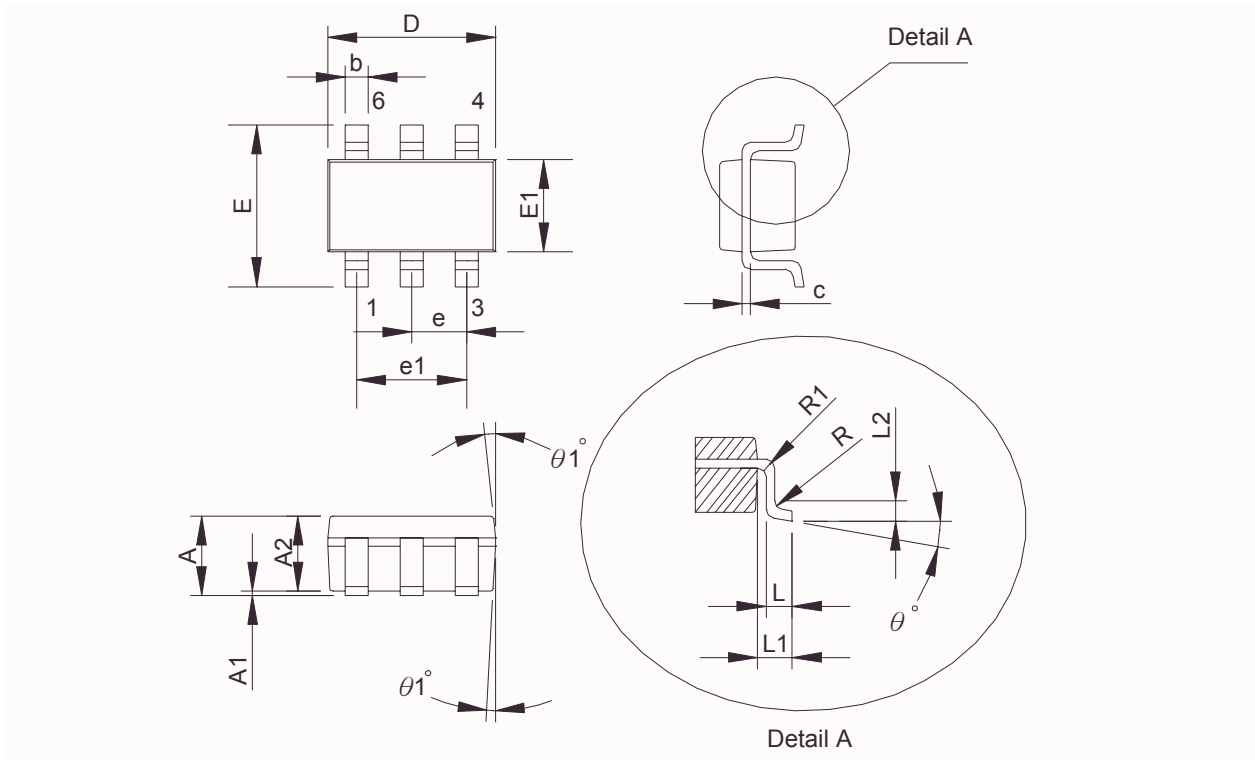

Dimensions

Symbol	Millimeters			Inches		
	Min.	Typ.	Max.	Min.	Typ.	Max.
A			1.45			0.057
A1			0.15			0.006
A2	0.90	1.15	1.30	0.036	0.045	0.051
b	0.30		0.50	0.011		0.020
c	0.08		0.22	0.003		0.009
D		2.90			0.114	
E		2.80			0.110	
E1		1.60			0.063	
e		0.95			0.037	
e1		1.90			0.075	
L	0.30	0.45	0.60	0.020	0.018	0.024
L1		0.60			0.024	
L2		0.25			0.010	
R	0.10			0.004		
R1	0.10		0.25	0.004		0.010
theta°	0°	4°	8°	0°	4°	8°
theta 1°	5°	10°	15°	5°	10°	15°

DISCLAIMERS

LIFE SUPPORT

System General's products are not designed to be used as components in devices intended to support or sustain human life. Use of System General's products in components intended for surgical implant into the body, or other applications in which failure of System General's products could create a situation where personal death or injury may occur, is not authorized without the express written approval of System General's Chief Executive Officer. System General will not be held liable for any damages or claims resulting from the use of its products in medical applications.

MILITARY

System General's products are not designed for use in military applications. Use of System General's products in military applications is not authorized without the express written approval of System General's Chief Executive Officer. System General will not be held liable for any damages or claims resulting from the use of its products in military applications.

RIGHT TO MAKE CHANGES

System General reserves the right to change this document and/or this product without notice. Customers are advised to consult their System General sales representative before ordering.