

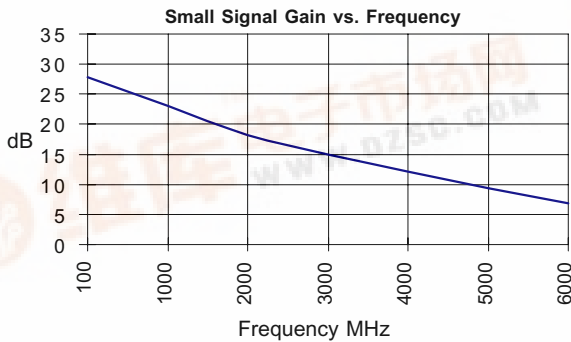

Product Description

Stanford Microdevices' SGA-6586 is a high performance cascadeable 50-ohm amplifier housed in a low-cost surface-mountable plastic package. Designed for operation at voltages as low as 5.0V, this RFIC uses the latest Silicon Germanium Heterostructure Bipolar Transistor (SiGe HBT) process featuring 1 micron emitters with F_T up to 50 GHz.

This circuit uses a darlington pair topology with resistive feedback for broadband performance as well as stability over its entire temperature range. Internally matched to 50 ohm impedance, the SGA-6586 requires only DC blocking and bypass capacitors for external components.



Preliminary

SGA-6586

DC-2500 MHz Silicon Germanium HBT Cascadeable Gain Block



Product Features

- DC-2500 MHz Operation
- Single Voltage Supply
- High Output Intercept: +34.0 dBm typ. at 850 MHz
- High Output Power : 21.5 dBm typ. at 850 MHz
- High Gain : 24.0 dB typ. at 850 MHz
- Internally Matched to 50 Ohms Input & Output

Applications

- Oscillator Amplifiers
- Final PA for Low Power Applications
- IF/RF Buffer Amplifier
- Drivers for CATV Amplifiers

Symbol	Parameters: Test Conditions: Z ₀ = 50 Ohms, I _d = 80 mA, T = 25°C		Units	Min.	Typ.	Max.
P _{1dB}	Output Power at 1dB Compression	f = 850 MHz f = 1950 MHz	dBm dBm		21.5 18.1	
S ₂₁	Small Signal Gain	f = DC - 1000 MHz f = 1000 - 2000 MHz f = 2000 - 2500 MHz	dB dB dB		25.6 20.3 17.2	
S ₁₂	Reverse Isolation	f = DC - 1000 MHz f = 1000 - 2000 MHz f = 2000 - 2500 MHz	dB dB dB		27.8 23.3 20.2	
S ₁₁	Input VSWR	f = DC - 2500 MHz	-		1.1:1	
S ₂₂	Output VSWR	f = DC - 2500 MHz	-		1.2:1	
IP ₃	Third Order Intercept Point Power out per tone = 3 dBm	f = 850 MHz f = 1950 MHz	dBm dBm		33.8 32.5	
NF	Noise Figure	f = DC - 1000 MHz f = 1000 - 2500 MHz	dB dB		2.6 3.4	
T _D	Group Delay	f = 1000 MHz	pS		163	
V _D	Device Voltage		V	4.6	5.0	5.4

The information provided herein is believed to be reliable at press time. Stanford Microdevices assumes no responsibility for inaccuracies or omissions. Stanford Microdevices assumes no responsibility for the use of this information, and all such information shall be entirely at the user's own risk. Prices and specifications are subject to change without notice. No patent rights or licenses to any of the circuits described herein are implied or granted to any third party. Stanford Microdevices does not authorize or warrant any Stanford Microdevices product for use in life-support devices and/or systems. Copyright 1999 Stanford Microdevices, Inc. All worldwide rights reserved.

522 Almanor Ave., Sunnyvale, CA 94086

Phone: (800) SMI-MMIC

http://www.stanfordmicro.com
EDS-101160 Rev B





Preliminary
SGA-6586 DC-2500 MHz 5.0V SiGe Amplifier

Parameter	Specification			Unit	Test Condition
	Min	Typ.	Max.		
Device Bias					T= 25C
Operating Voltage	4.6	5.0	5.4	V	
Operating Current		80.0		mA	
500 MHz					T= 25C
Gain	21.5	25.8		dB	
Noise Figure		2.5		dB	
Output IP3		32.2		dBm	
Output P1dB		20.9		dBm	
Input Return Loss		19.9		dB	
Isolation		28.0		dB	
850 MHz					T= 25C
Gain		23.8		dB	
Noise Figure		2.7		dB	
Output IP3		33.8		dBm	
Output P1dB		21.5		dBm	
Input Return Loss		23.3		dB	
Isolation		26.5		dB	
1950 MHz					T= 25C
Gain		18.4		dB	
Noise Figure		3.1		dB	
Output IP3		32.2		dBm	
Output P1dB		18.0		dBm	
Input Return Loss		23.7		dB	
Isolation		21.4		dB	
2400 MHz					T= 25C
Gain		16.7		dB	
Noise Figure		3.7		dB	
Output IP3		30.2		dBm	
Output P1dB		16.8		dBm	
Input Return Loss		18.2		dB	
Isolation		19.7		dB	

The information provided herein is believed to be reliable at press time. Stanford Microdevices assumes no responsibility for inaccuracies or omissions. Stanford Microdevices assumes no responsibility for the use of this information, and all such information shall be entirely at the user's own risk. Prices and specifications are subject to change without notice. No patent rights or licenses to any of the circuits described herein are implied or granted to any third party. Stanford Microdevices does not authorize or warrant any Stanford Microdevices product for use in life-support devices and/or systems.
Copyright 1999 Stanford Microdevices, Inc. All worldwide rights reserved.

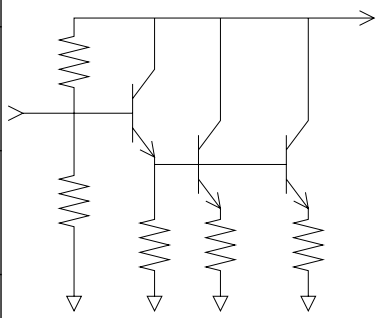
Pin #	Function	Description	Device Schematic
1	RF IN	RF input pin. This pin requires the use of an external DC blocking capacitor chosen for the frequency of operation.	
2	GND	Connection to ground. Use via holes for best performance to reduce lead inductance as close to ground leads as possible.	
3	RF OUT/ BIAS	RF output and bias pin. DC voltage is present on this pin, therefore a DC blocking capacitor is necessary for proper operation.	
4	GND	Sames as Pin 2	

Application Schematic for Operation at 900 MHz

Recommended Bias Resistor Values				
Supply Voltage(Vs)	6V	8V	9V	12V
Rbias (Ohms)	12	36	51	91

For 8V operation or higher, a resistor with a power handling capability of 1/2W or greater is recommended.

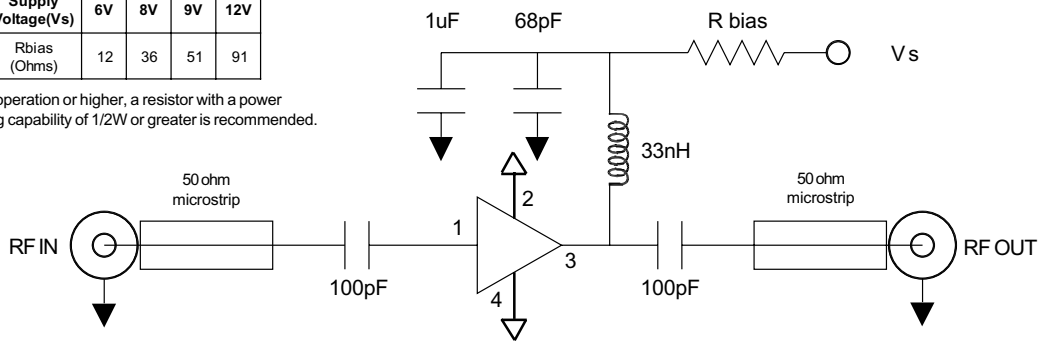

Application Schematic for Operation at 1900 MHz

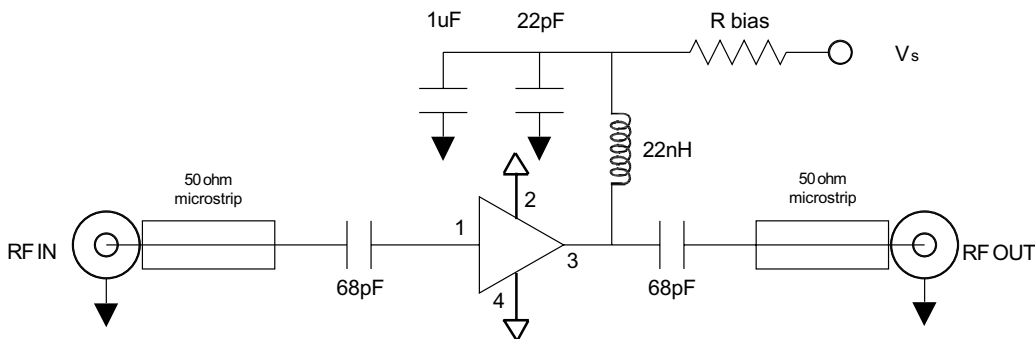

The information provided herein is believed to be reliable at press time. Stanford Microdevices assumes no responsibility for inaccuracies or omissions. Stanford Microdevices assumes no responsibility for the use of this information, and all such information shall be entirely at the user's own risk. Prices and specifications are subject to change without notice. No patent rights or licenses to any of the circuits described herein are implied or granted to any third party. Stanford Microdevices does not authorize or warrant any Stanford Microdevices product for use in life-support devices and/or systems. Copyright 1999 Stanford Microdevices, Inc. All worldwide rights reserved.



Preliminary
SGA-6586 DC-2500 MHz 5.0V SiGe Amplifier

S21, Id = 80mA, T=25C

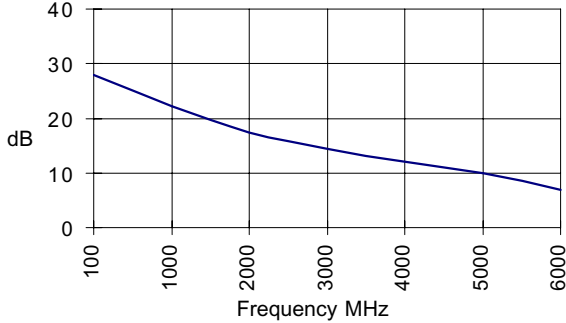

S12, Id = 80mA, T=25C

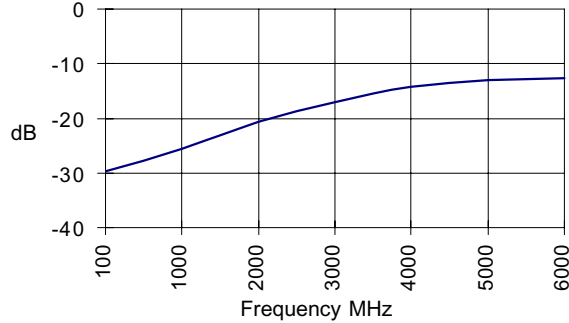

S11, Id = 80mA, T=25C

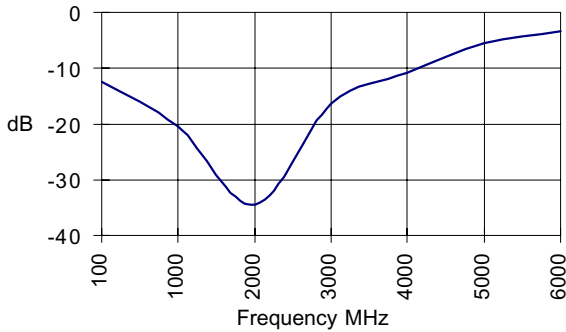

S22, Id = 80mA, T=25C

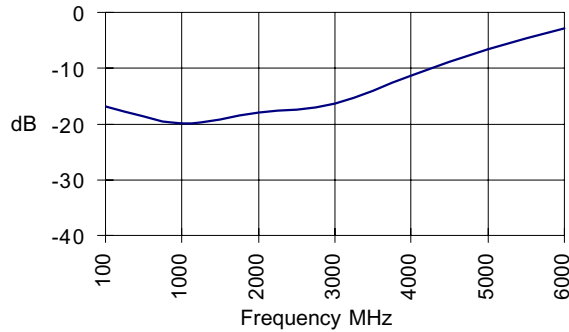

S11, Id=80mA, Ta=25C

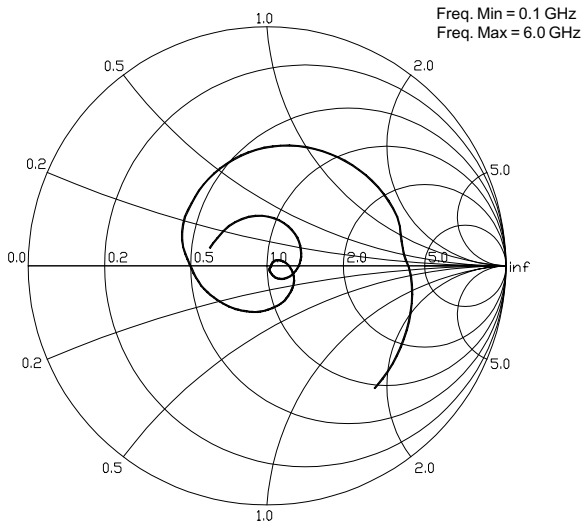

S22, Id=80mA, Ta=25C

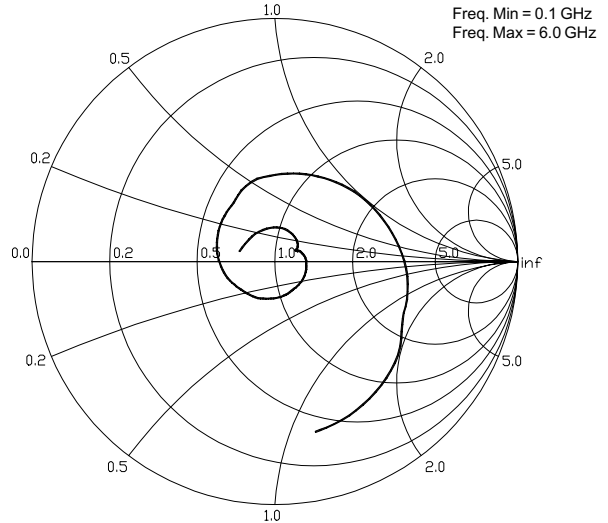

The information provided herein is believed to be reliable at press time. Stanford Microdevices assumes no responsibility for inaccuracies or omissions. Stanford Microdevices assumes no responsibility for the use of this information, and all such information shall be entirely at the user's own risk. Prices and specifications are subject to change without notice. No patent rights or licenses to any of the circuits described herein are implied or granted to any third party. Stanford Microdevices does not authorize or warrant any Stanford Microdevices product for use in life-support devices and/or systems. Copyright 1999 Stanford Microdevices, Inc. All worldwide rights reserved.



Preliminary
SGA-6586 DC-2500 MHz 5.0V SiGe Amplifier

S21, Id=80mA, T=-40C

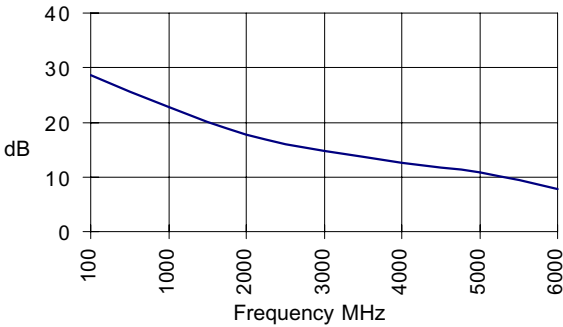

S12, Id=80mA, T=-40C

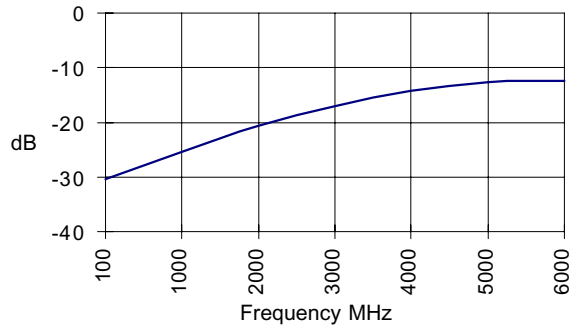

S11, Id=80mA, T=-40C

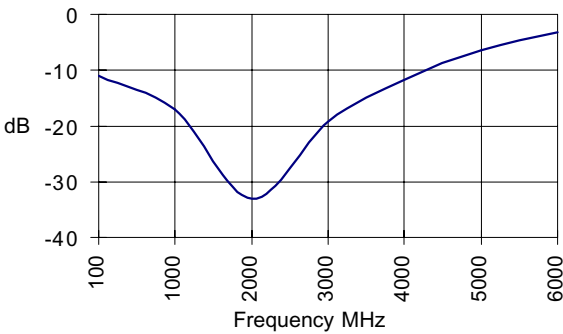

S22, Id=80mA, T=-40C

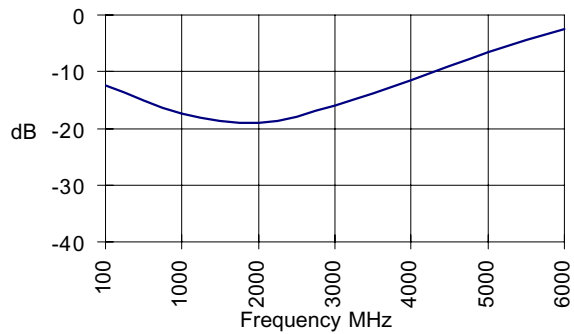

S11, Id=80mA, Ta=-40C

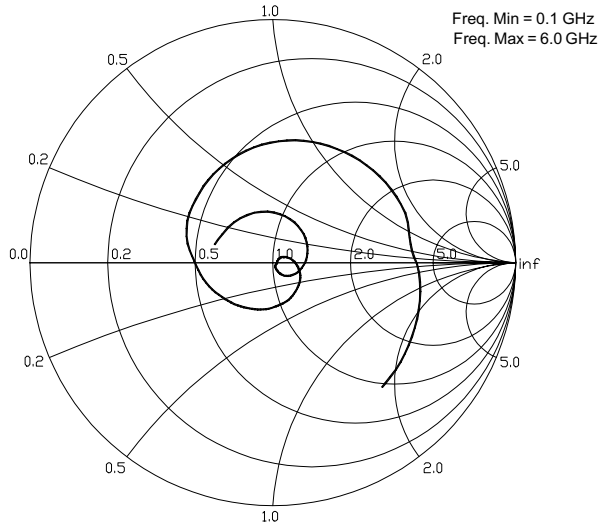

S22, Id=80mA, Ta=-40C

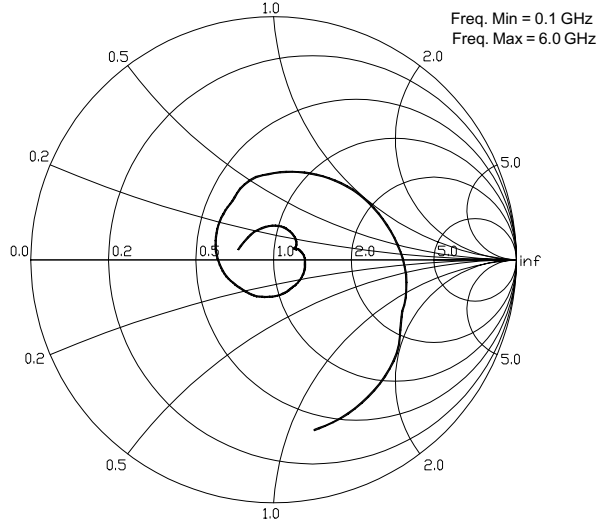

The information provided herein is believed to be reliable at press time. Stanford Microdevices assumes no responsibility for inaccuracies or omissions. Stanford Microdevices assumes no responsibility for the use of this information, and all such information shall be entirely at the user's own risk. Prices and specifications are subject to change without notice. No patent rights or licenses to any of the circuits described herein are implied or granted to any third party. Stanford Microdevices does not authorize or warrant any Stanford Microdevices product for use in life-support devices and/or systems. Copyright 1999 Stanford Microdevices, Inc. All worldwide rights reserved.



Preliminary
SGA-6586 DC-2500 MHz 5.0V SiGe Amplifier

S21, Id =80mA, T=85C

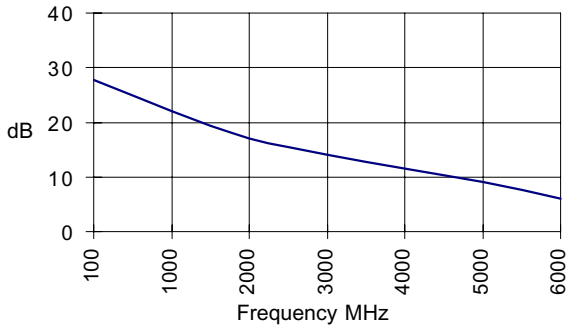

S12, Id =80mA, T=85C

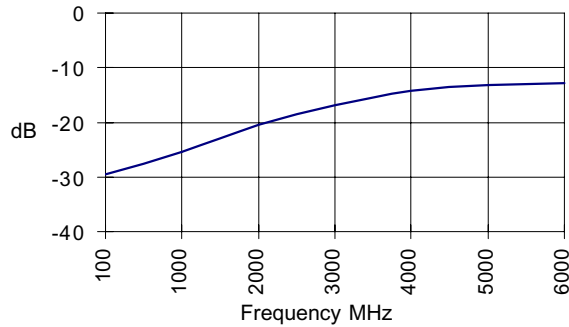

S11, Id =80mA, T=85C

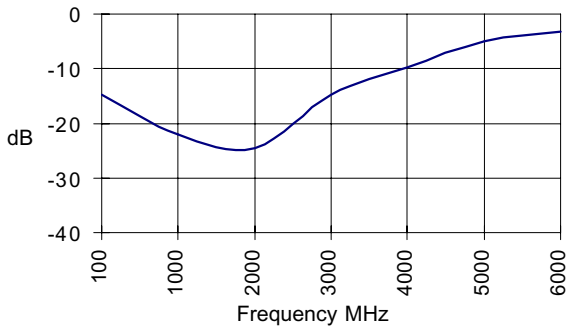

S22, Id =80mA, T=85C

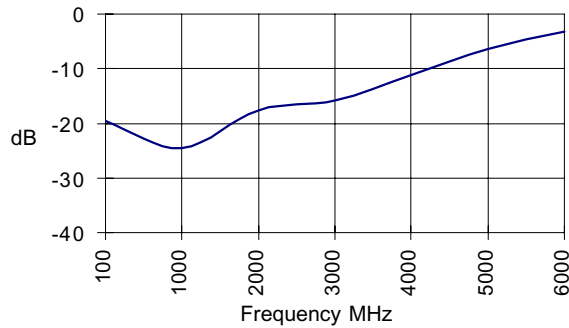

S11, Id=80mA, Ta=85C

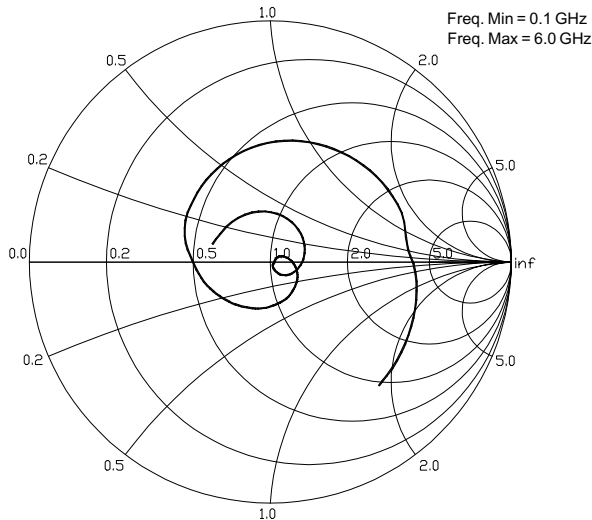

S22, Id=80mA, Ta=85C

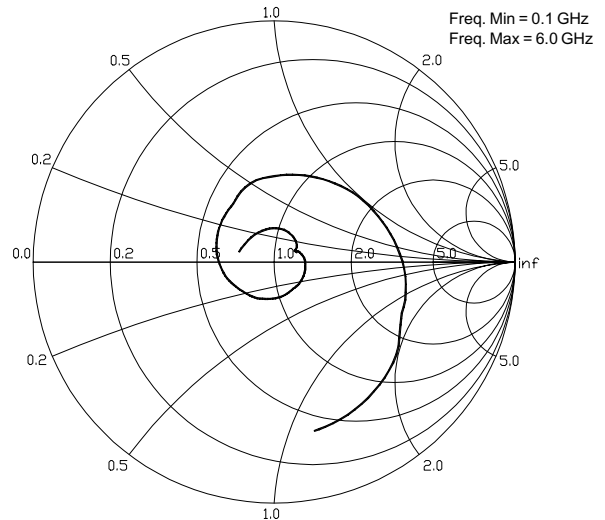

The information provided herein is believed to be reliable at press time. Stanford Microdevices assumes no responsibility for inaccuracies or omissions. Stanford Microdevices assumes no responsibility for the use of this information, and all such information shall be entirely at the user's own risk. Prices and specifications are subject to change without notice. No patent rights or licenses to any of the circuits described herein are implied or granted to any third party. Stanford Microdevices does not authorize or warrant any Stanford Microdevices product for use in life-support devices and/or systems. Copyright 1999 Stanford Microdevices, Inc. All worldwide rights reserved.



Preliminary
SGA-6586 DC-2500 MHz 5.0V SiGe Amplifier

Absolute Maximum Ratings

Parameter	Value	Unit
Supply Current	160	mA
Operating Temperature	-40 to +85	C
Maximum Input Power	+6	dBm
Storage Temperature Range	-40 to +150	C
Operating Junction Temperature	+150	C

Part Number Ordering Information

Part Number	Reel Size	Devices/Reel
SGA-6586	13"	3000



Caution:

Operation of this device above any one of these parameters may cause permanent damage. Appropriate precautions in handling, packaging and testing devices must be observed.

Thermal Resistance (Lead-Junction):
 97° C/W

Package Dimensions

Pin Designation	
1	RF in
2	GND
3	RF out and Bias
4	GND

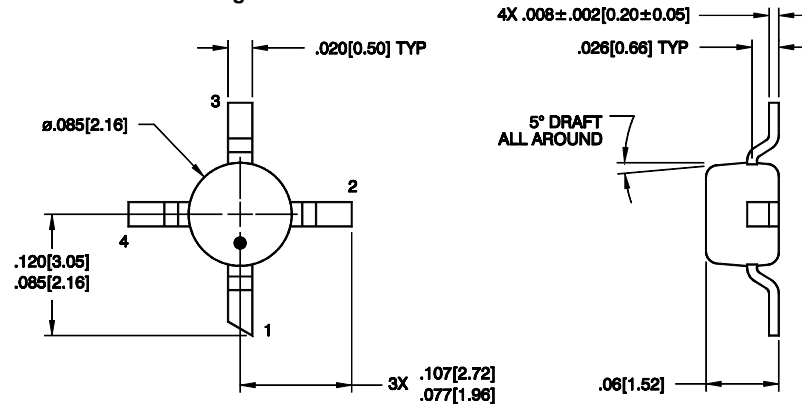

PCB Pad Layout

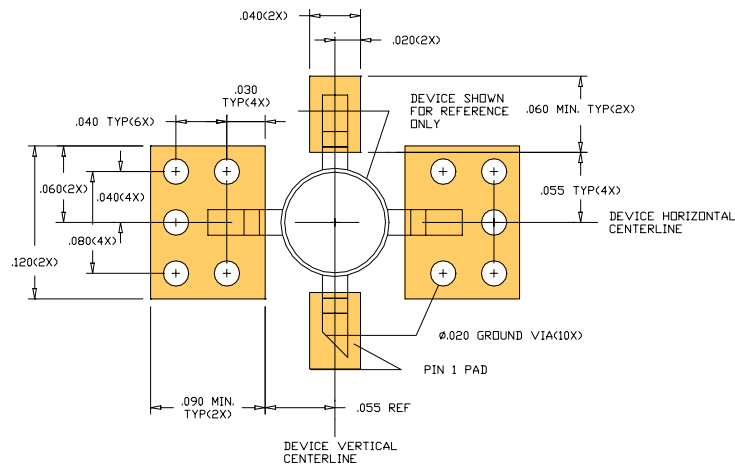

The information provided herein is believed to be reliable at press time. Stanford Microdevices assumes no responsibility for inaccuracies or omissions. Stanford Microdevices assumes no responsibility for the use of this information, and all such information shall be entirely at the user's own risk. Prices and specifications are subject to change without notice. No patent rights or licenses to any of the circuits described herein are implied or granted to any third party. Stanford Microdevices does not authorize or warrant any Stanford Microdevices product for use in life-support devices and/or systems. Copyright 1999 Stanford Microdevices, Inc. All worldwide rights reserved.