

SONY

SGM2013N

GaAs N-channel Dual-Gate MES FET

Description

The SGM2013N is an N-channel dual-gate GaAs MES FET for UHF-band low-noise amplification. This FET is suitable for a wide range of applications including cellular/cordless phone.

Features

- Ultra-small package
- Low voltage operation
- Low noise NF = 1.4dB (Typ) at 900MHz, NF = 1.7dB (Typ) at 1.5GHz
- High gain Ga = 18dB (Typ) at 900MHz, Ga = 16dB (Typ) at 1.5GHz
- High stability
- Built-in gate protection diode

Application

UHF-band high-frequency amplifier and mixer

Structure

GaAs, N-channel, dual-gate metal semiconductor field-effect transistor

Absolute Maximum Ratings (Ta = 25°C)

• Drain to source voltage	V _{DSX}	6	V
• Gate 1 to source voltage	V _{G1S}	-4	V
• Gate 2 to source voltage	V _{G2S}	-4	V
• Drain current	I _D	18	mA
• Allowable power dissipation	P _D	100	mW
• Channel temperature	T _{ch}	125	°C
• Storage temperature	T _{stg}	-55 to +150	°C

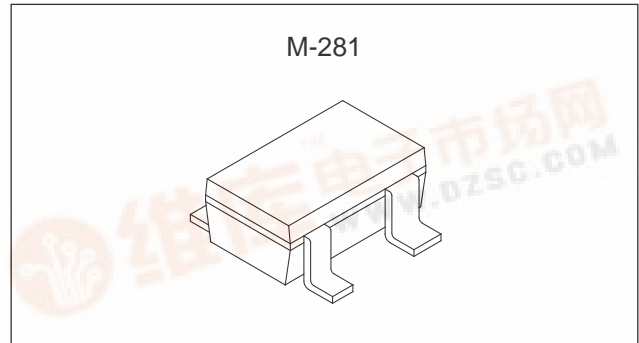

Sony reserves the right to change products and specifications without prior notice. This information does not convey any license by any implication or otherwise under any patents or other right. Application circuits shown, if any, are typical examples illustrating the operation of the devices. Sony cannot assume responsibility for any problems arising out of the use of these circuits.



Electrical Characteristics

(Ta = 25°C)

Item	Symbol	Conditions	Min.	Typ.	Max.	Unit
Gate 1 to source current	I _{G1SS}	V _{G1S} = -3V V _{G2S} = 0V V _{DS} = 0V			-4	μA
Gate 2 to source current	I _{G2SS}	V _{G2S} = -3V V _{G1S} = 0V V _{DS} = 0V			-4	μA
Drain saturation current	I _{DSS}	V _{DS} = 2V V _{G1S} = 0V V _{G2S} = 0V	4		16	mA
Gate 1 to source cut-off voltage	V _{G1S} (OFF)	V _{DS} = 2V I _D = 100μA V _{G2S} = 0V			-1.5	V
Gate 2 to source cut-off voltage	V _{G2S} (OFF)	V _{DS} = 2V I _D = 100μA V _{G1S} = 0V			-1.5	V
Forward transfer admittance	g _m	V _{DS} = 2V I _D = 2mA V _{G2S} = 0.5V f = 1kHz	8	11		ms
Input capacitance	C _{iss}	V _{DS} = 2V I _D = 2mA		0.55	1	pF
Feedback capacitance	C _{rss}	V _{G2S} = 0.5V f = 1MHz		15	30	fF
Noise figure	NF	V _{DS} = 2V I _D = 2mA		1.4	2.5	dB
NF associated gain	G _a	V _{G2S} = 0.5V f = 900MHz	15	18		dB

Typical Characteristics (Ta = 25°C)

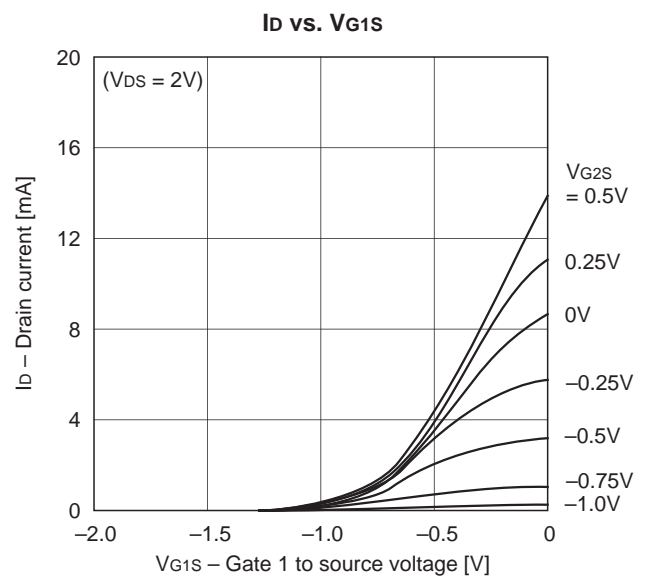
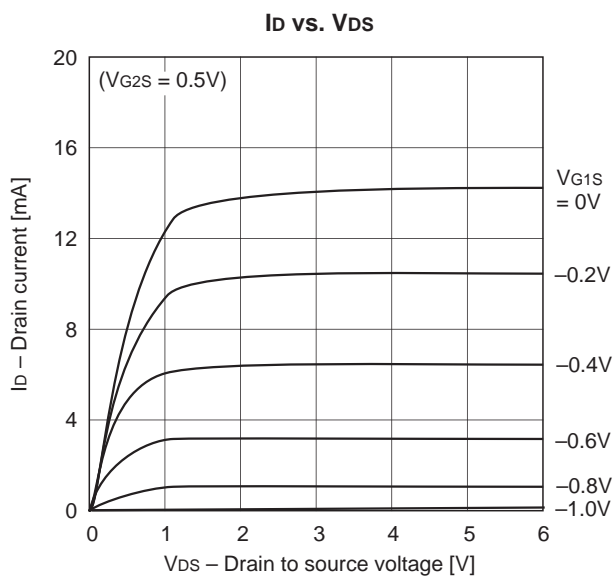

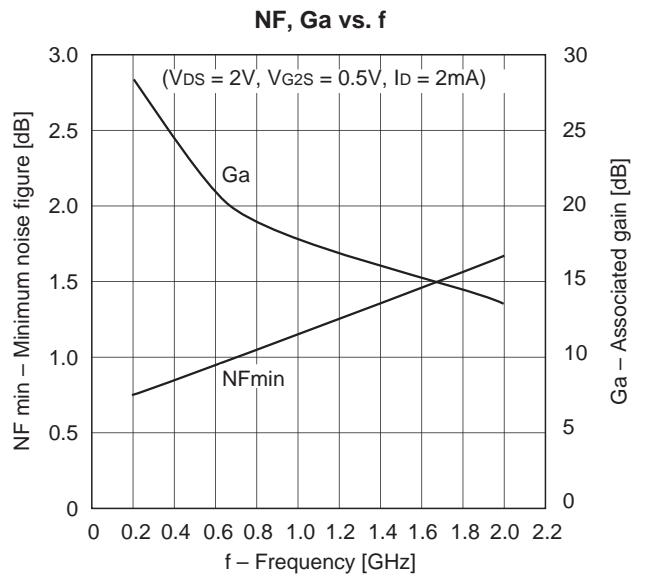
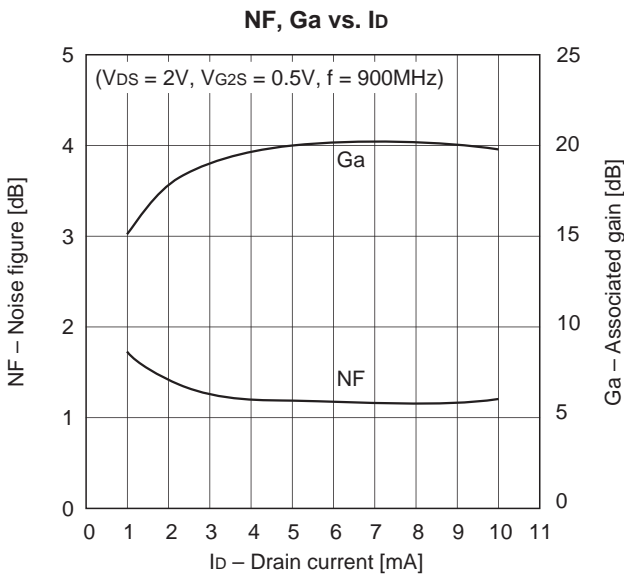
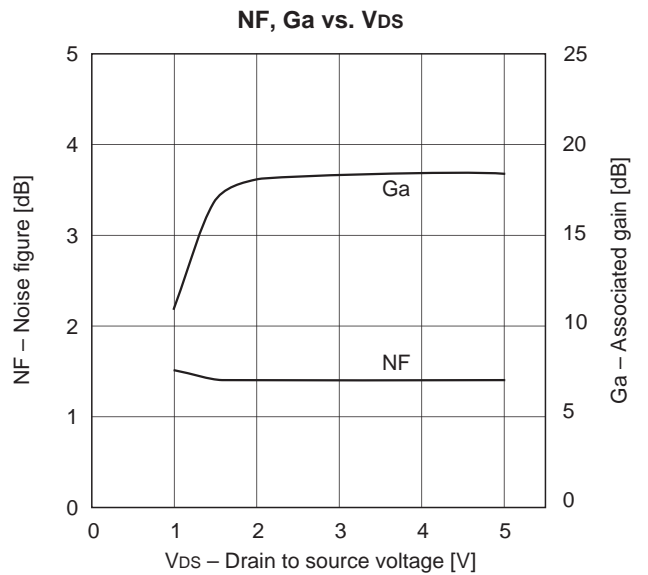
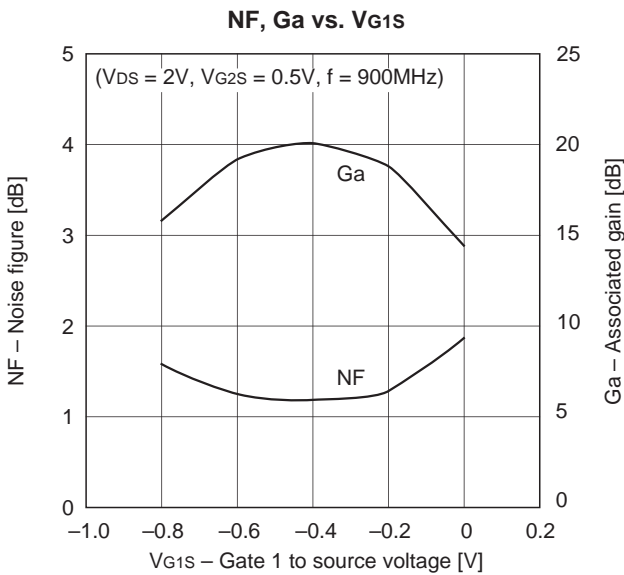
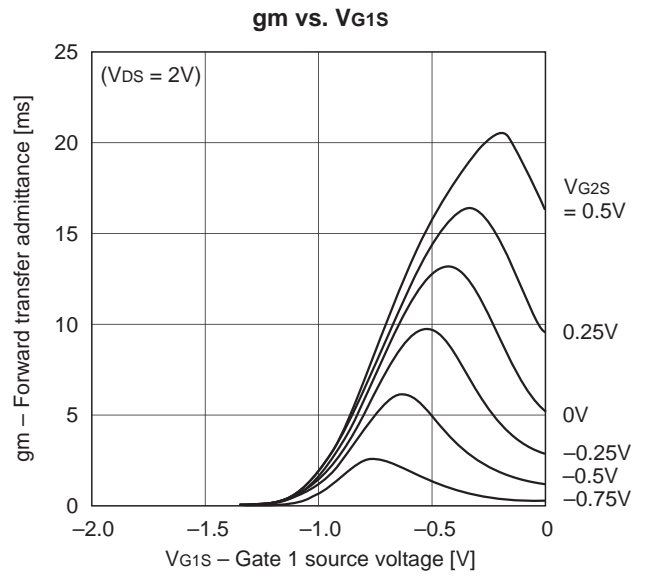
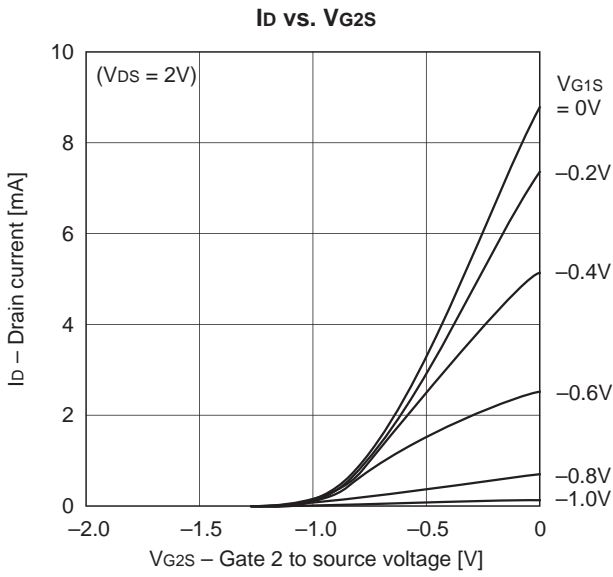

S-parameter vs. Frequency Characteristics ($V_{DS} = 2V$, $V_{G2S} = 0.5V$, $I_D = 2mA$)

f (MHz)	S11		S21		S12		S22	
	MAG	ANG	MAG	ANG	MAG	ANG	MAG	ANG
200	0.99	-4.3	1.01	172.8	0.00	87.0	0.98	-2.0
300	0.99	-6.4	1.01	169.3	0.00	85.4	0.98	-3.1
400	0.99	-8.5	1.01	165.9	0.00	84.7	0.98	-4.0
500	0.99	-10.7	1.01	162.2	0.00	83.0	0.98	-5.2
600	0.98	-12.8	1.01	158.7	0.00	81.9	0.98	-6.1
700	0.98	-15.0	1.01	155.1	0.01	80.3	0.98	-7.2
800	0.97	-17.2	1.01	151.5	0.01	78.9	0.98	-8.3
900	0.96	-19.3	1.01	147.8	0.01	77.8	0.98	-9.7
1000	0.96	-21.5	1.01	144.3	0.01	76.9	0.97	-10.5
1100	0.95	-23.7	1.00	140.6	0.01	75.8	0.97	-11.7
1200	0.94	-26.0	1.00	137.2	0.01	75.0	0.96	-12.7
1300	0.93	-28.1	1.00	133.6	0.01	73.8	0.96	-13.8
1400	0.92	-30.3	0.99	130.0	0.01	72.9	0.96	-14.8
1500	0.91	-32.6	0.99	126.5	0.01	72.8	0.96	-15.9
1600	0.90	-34.9	0.99	122.8	0.01	72.5	0.96	-16.9
1700	0.89	-37.0	0.98	119.4	0.01	71.5	0.96	-18.0
1800	0.88	-39.0	0.98	115.7	0.01	70.9	0.95	-19.0
1900	0.86	-41.4	0.97	112.1	0.01	69.7	0.95	-20.0
2000	0.85	-43.6	0.97	108.8	0.01	68.6	0.95	-20.6

Noise Figure Characteristics ($V_{DS} = 2V$, $V_{G2S} = 0.5V$, $I_D = 2mA$)

f (MHz)	NFmin (dB)	Gamma Optimum		Rn (Ω)
		ANG	MAG	
200	0.76	0.99	4.2	85.0
300	0.80	0.99	6.1	83.9
400	0.85	0.99	8.0	82.9
500	0.90	0.98	9.8	81.9
600	0.96	0.96	11.5	80.9
700	1.01	0.95	13.2	79.9
800	1.06	0.93	14.8	79.0
900	1.11	0.91	16.4	78.1
1000	1.16	0.89	18.0	77.2
1100	1.21	0.87	19.6	76.3
1200	1.26	0.85	21.1	75.5
1300	1.31	0.84	22.6	74.7
1400	1.36	0.82	24.2	74.0
1500	1.41	0.81	25.8	73.3
1600	1.45	0.80	27.4	72.6
1700	1.51	0.80	29.1	71.9
1800	1.56	0.80	30.8	71.3
1900	1.61	0.80	32.5	70.7
2000	1.67	0.80	34.4	70.1

Package Outline

Unit: mm

M-281

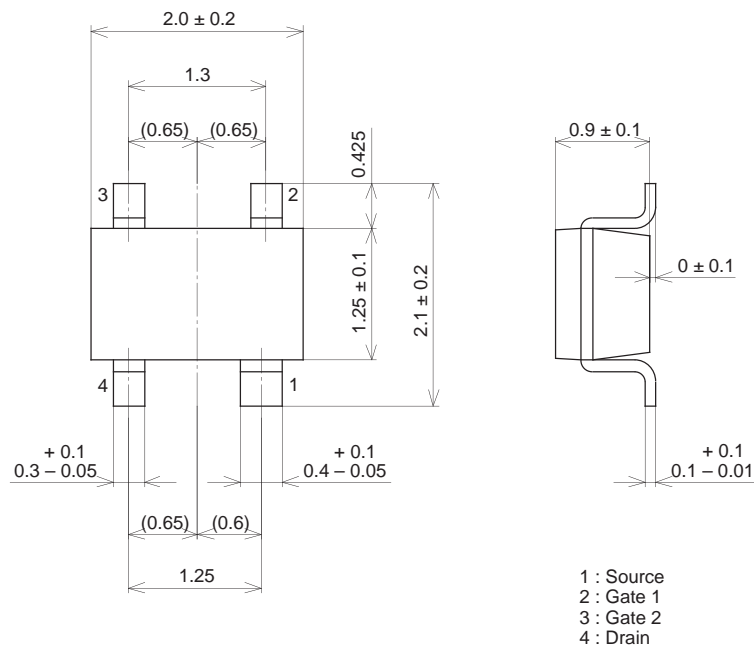

SONY CODE	M-281
EIAJ CODE	—
JEDEC CODE	—

PACKAGE MATERIAL	EPOXY RESIN
LEAD TREATMENT	SOLDER PLATING
LEAD MATERIAL	COPPER
PACKAGE WEIGHT	0.1g