

# SI-7200E, SI-7230E Series

## Stepping Motor Driver

### Features:

Effective power saving, high torque and fast transient response.

- 1) Chopped constant current drive made it unnecessary to put series resistor.
- 2) Full bridge bipolar driver made it possible to use the coils of motor effectively.
- 3) Surge voltage utilization reuses the inductive energy by charging it to capacitor, which does not require damping circuit.

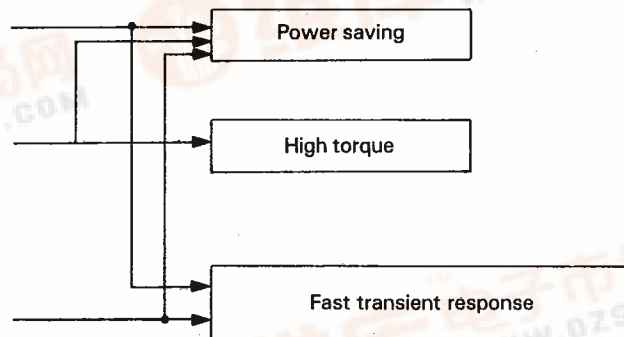

The IC makes total system compact because of low power dissipation and because of integrated circuit utilization. Output torque can be controlled easily by PWM circuit. It can be applied to the double1-2 phase excitation motors.

Outline Drawings Unit: mm

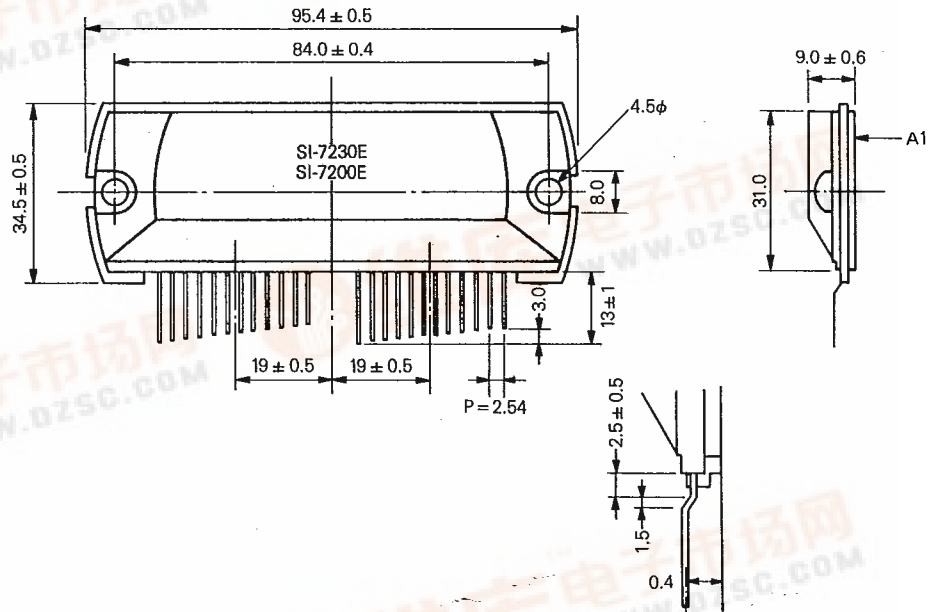

### Absolute Maximum Ratings (Ta = 25°C)

Description	Symbol	Unit	Rating	
			SI-7200E	SI-7230E
Supply Voltage	Vcc	V	60	
Surge Voltage	Vcc	V	70(Surge)	
Output Current	Io	A	1.2	3.0
Junction Temperature	Tj	°C	125	
Operating Temperature	Top	°C	-20 ~ +80	
Storage Temperature	Tstg	°C	-30 ~ +100	

T-52-13-25

# SI-7200E, SI-7230E Series

Electrical Characteristics (Ta=25°C)

Description	Symbol	Unit	Rating					
			SI-7200E			SI-7230E		
			MIN	TYP	MAX	MIN	TYP	MAX
Supply Voltage	Vcc	V	20		50	20		50
Output Current	Io	A			1.0			2.5
Input Current	IIN	mA			1.6			1.6

SI-7200E Equivalent Circuit

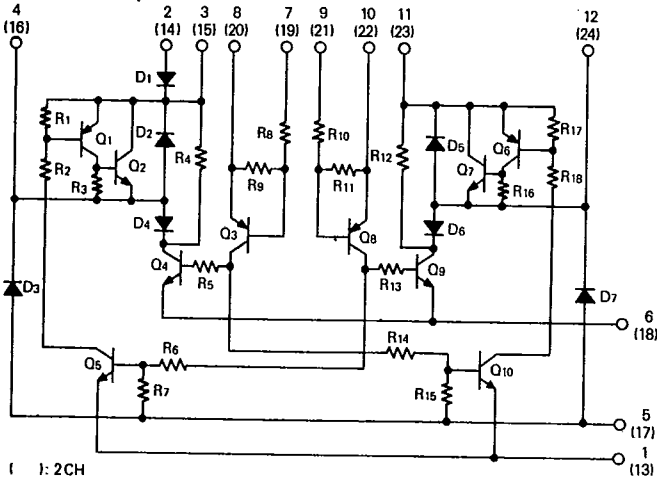

SI-7230E Equivalent Circuit

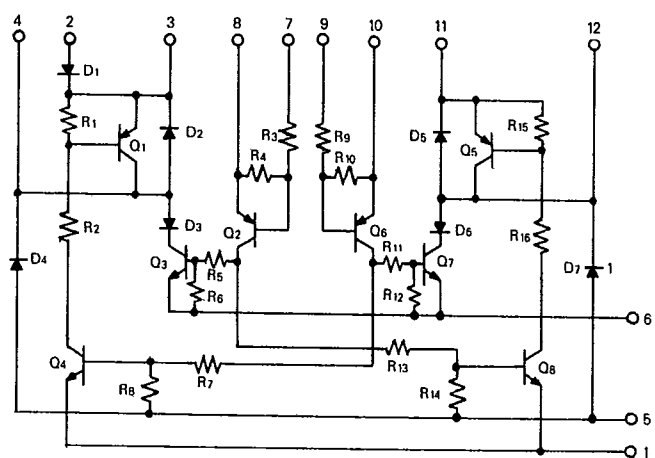

SI-7200E, SI-7230E Connections

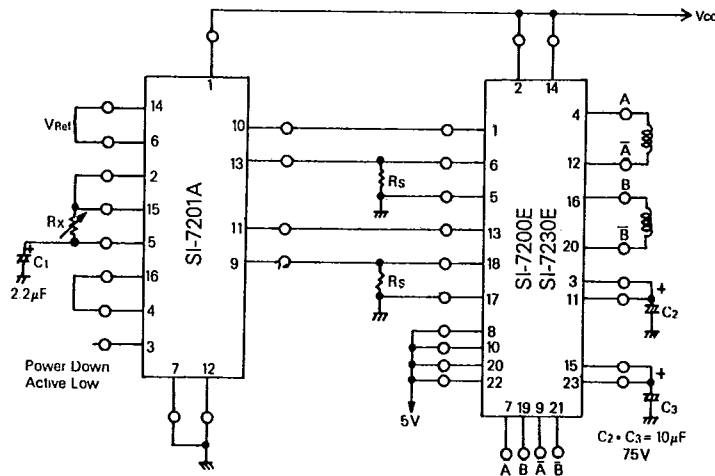

Vref = Reference Voltage (0.8V) Rx = 0  
Coil Current =  $\frac{V_{ref}}{R_x}$

1-phase, 2-phase or 1/2 phase  
Active Low

T-52-13-25  
Stepping Motor Driver

SI-7200E Derating

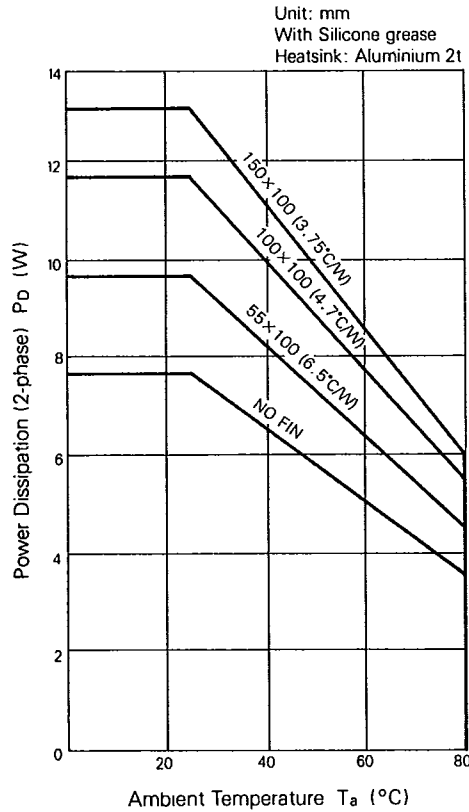

SI-7230E Derating

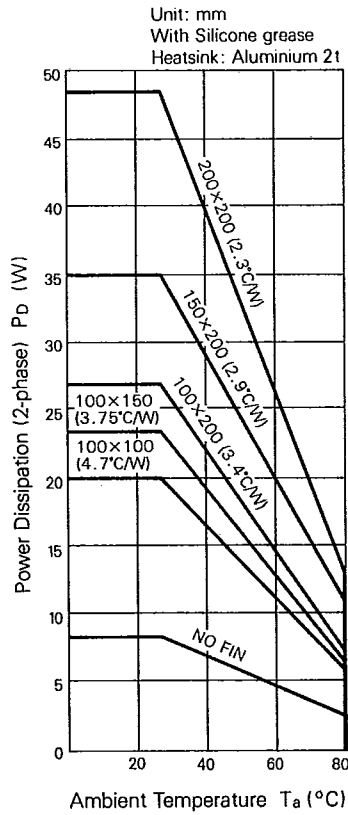

SI-7200E  
Power Dissipation (1-phase) vs.  
Coil Current Characteristics

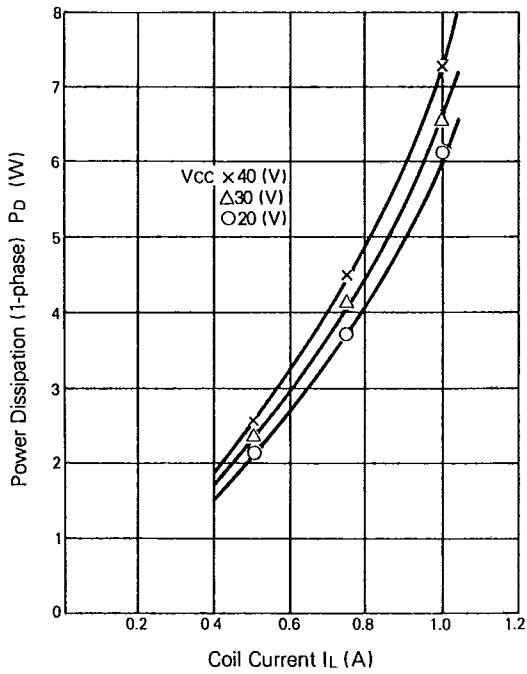

SI-7230E  
Power Dissipation (1-phase) vs.  
Coil Current Characteristics

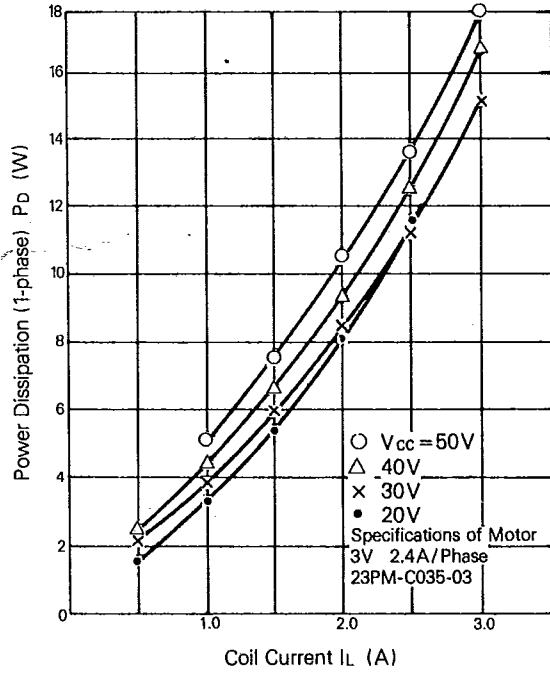

T-52-13-25

# SI-7200E, SI-7230E Series

SI-7200E Power Dissipation (1-phase) vs. Supply Voltage Characteristics

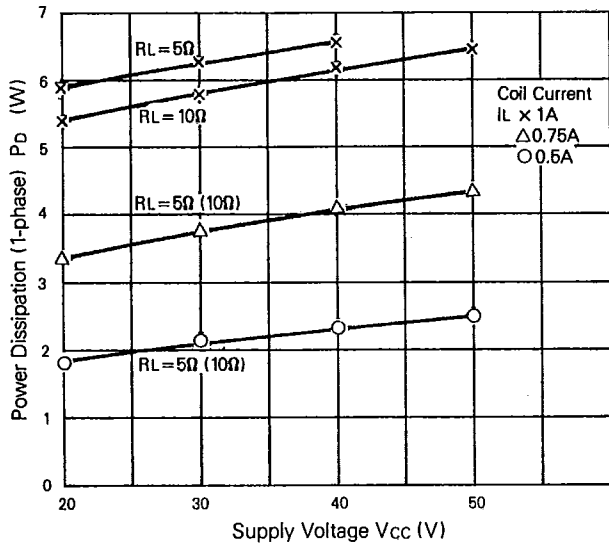

SI-7200E Power Dissipation (1-phase) vs. Coil Resistance Characteristics

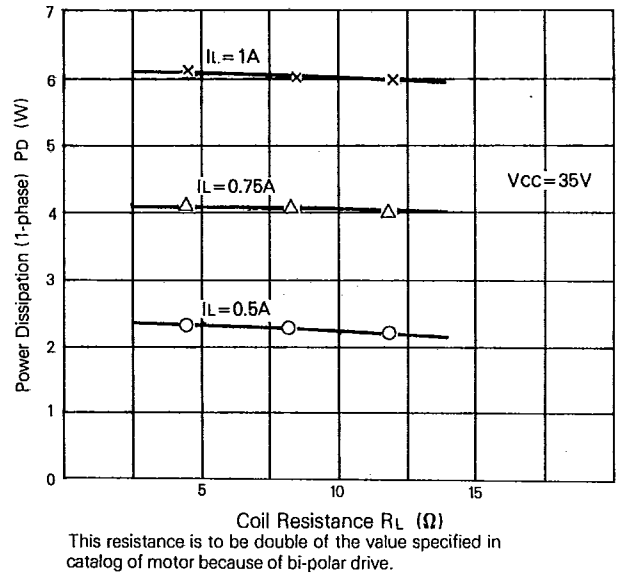

SI-7200E Operating Voltage Range

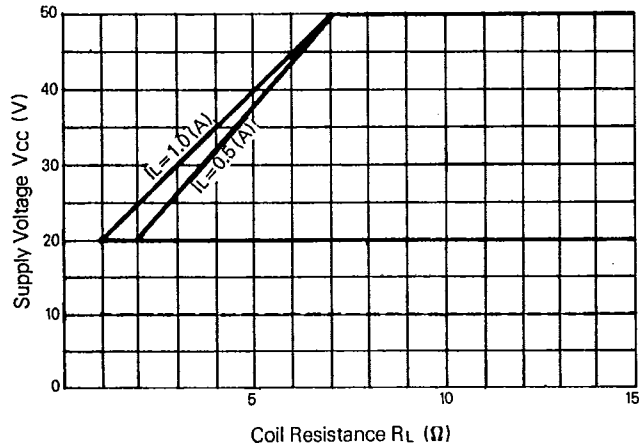

SI-7200E Thermal Resistance vs. Fin Characteristics

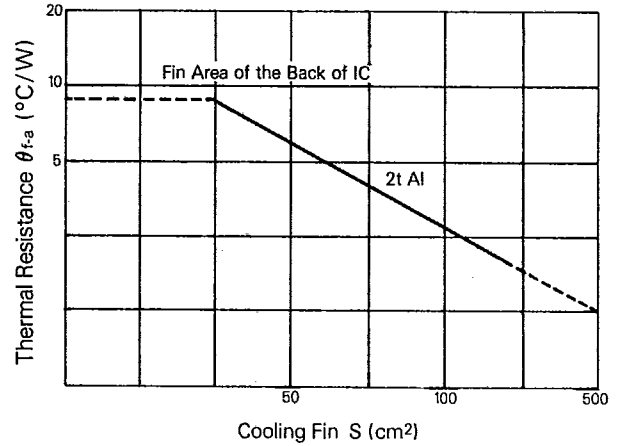

Single-Dual Phase Excitation Time Chart

	A	B	$\bar{A}$	$\bar{B}$	Ad	Bd
1	0	1	1	1	1	1
2	0	0	1	1	1	0
3	0	0	1	1	0	1
4	0	0	1	1	0	1
5	1	0	1	1	1	1
6	1	0	0	1	0	1
7	1	0	0	1	1	1
8	1	0	0	1	1	0
9	1	1	0	1	1	1
10	1	1	0	0	1	0
11	1	1	0	0	1	1
12	1	1	0	0	0	1
13	1	1	1	0	1	1
14	0	1	1	0	0	1
15	0	1	1	0	1	1
16	0	1	1	0	1	0
17	1	0	1	1	1	1

