

Bipolar Driver IC

捷多邦, 专业PCB打样工厂, 24小时加急出货

SI-7230M

■ Ratings

(Ta = 25°C)

Type No.	Supply voltage (V)		Peak voltage of pins CA and Cb (V)	Output current (A)		Junction temperature (°C)	Operating ambient temperature (°C)	Storage temperature (°C)
	Vcc1	Vcc2	Vsp	Io	Iom	Tj	Top	Tstg
SI-7230M	50	7	70	3.2		+125	-20 to +80	-30 to +100

■ Characteristics

Type No.	Supply voltage (V)						Output current (mA/ø)						*Comparator threshold voltage (V)						Excitation signal input voltage (V)				Excitation signal input current (mA)	Oscillation frequency (kHz)				Vcc2 input current (mA)
	Vcc1			Vcc2			Io		Iom				VTHF			VTHPD			VIL(ON)		VIH(OFF)		IIL	F				Icc2
	min	typ	max	min	typ	max	min	max	min	typ	max	min	typ	max	min	typ	max	min	max	min	max	max	min	typ	max	max		
SI-7230M	15	30	45	4.5	5	5.5	200	3000	535	580	625	1.025	1.125	1.225	0.515	0.555	0.595	0	0.5	Vcc2 -0.4	Vcc2 +2	1.6	19	21	25	150		

*V_{THF} : Conditions shown in the standard external connection diagram with V_{CC2} = 5V and R_S = 1Ω

V_{THPD} : Conditions shown in the standard external connection diagram with R_X = 1kΩ, V_{CC2} = 5V and R_S = 1Ω

■ Block diagram

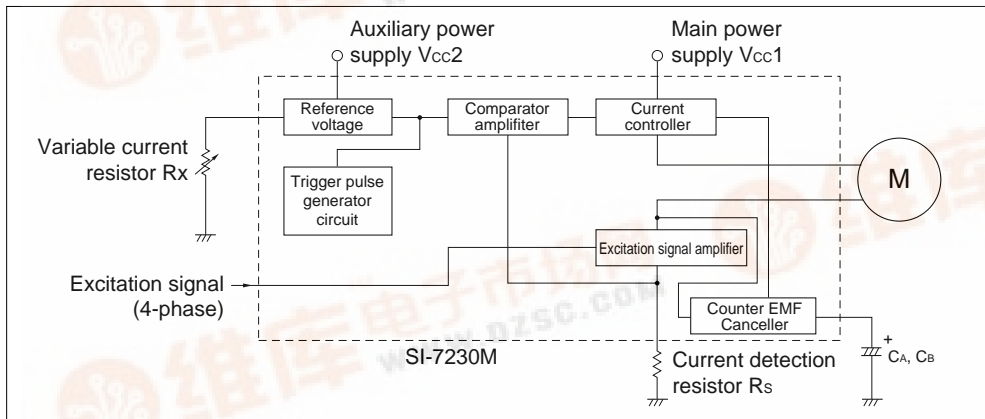

■ Equivalent circuit diagram

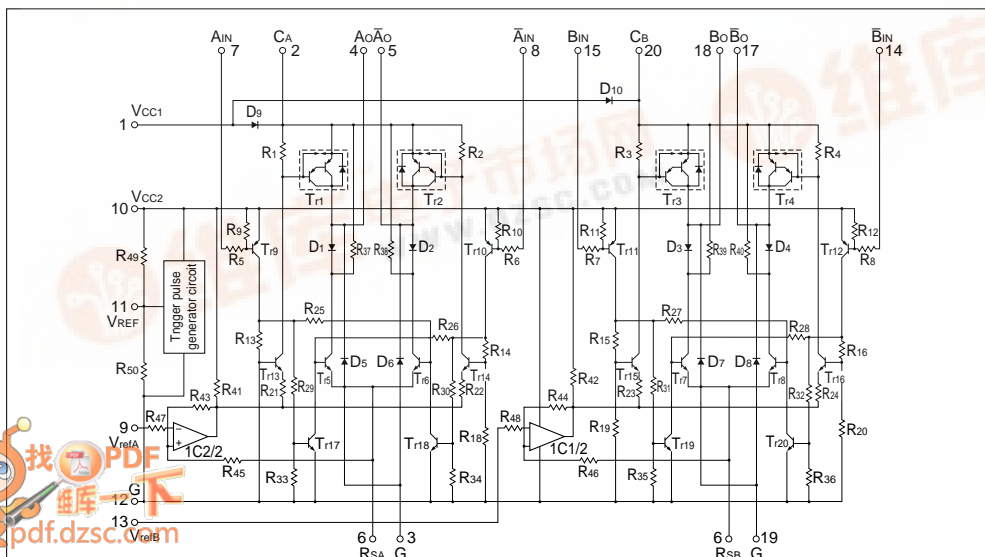

SI-7230M

External dimensions (Unit: mm)

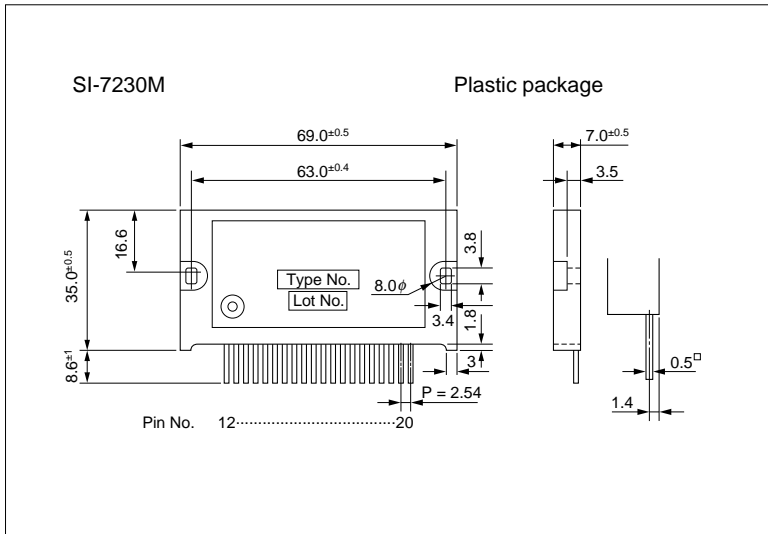

Standard external connection diagram

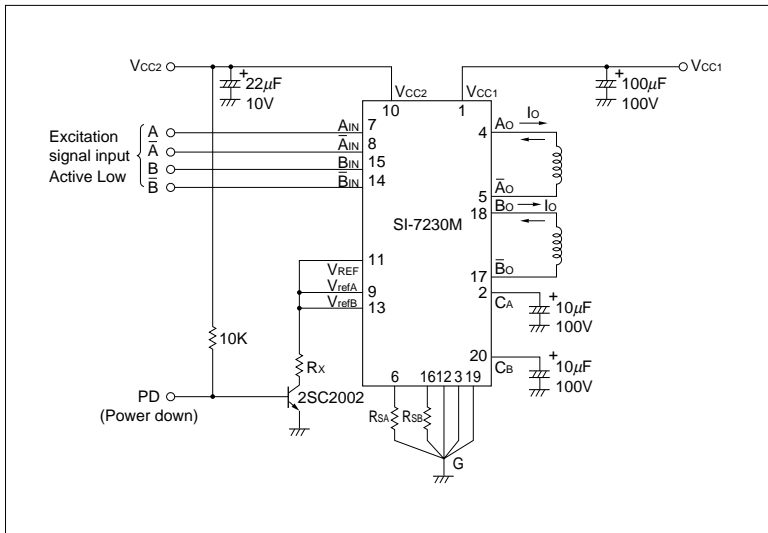

* For details on the characteristics and thermal design, refer to the technical manual.

SI-7230M

Application Note

■ Determining the output current I_o (motor coil current)

The output current, I_o is fixed by the following elements:

- R_s : Current detection resistor
- V_{CC2} : Supply voltage
- R_x : Variable current resistor

To operate a motor at maximum current level, set R_x to infinity (open).

To compute I_o when different values are used for R_s and V_{CC2} , use the approximation formula below. The maximum ripple value I_{OH} of the output current waveform can be computed as follows:

$$I_{OH(max)} = \frac{1}{R_s} (0.233 \cdot V_{CC2} - 0.026) \text{ [A]}$$

$$I_{OH(min)} = \frac{1}{R_s} (0.214 \cdot V_{CC2} - 0.021) \text{ [A]}$$

The graph of the equations above is shown below.

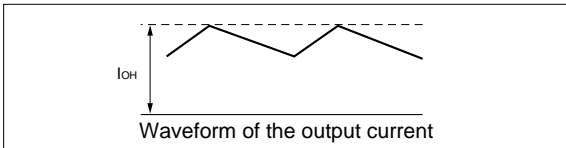

SI-7230M Output current I_{OH} vs. Current detection resistor R_s

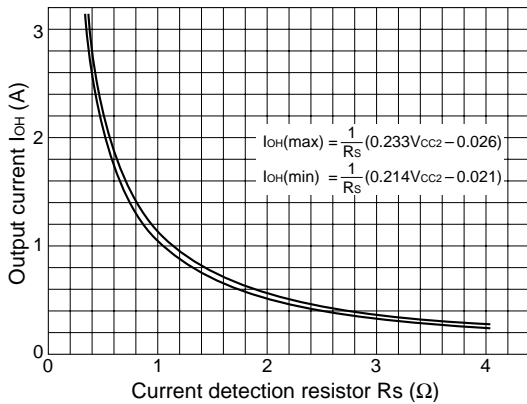

SI-7230M Output current I_{OH} vs. Variable current resistor R_x

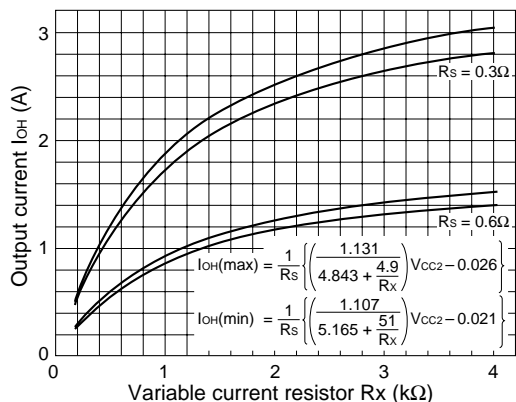

■ Power down mode

SI-7230M can be operated in power down mode. The circuit is shown below. When transistor T_r is switched on, the reference voltage drops and the output current can be decreased.

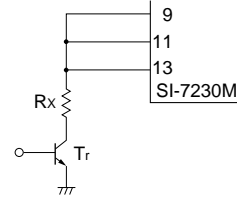

■ Surge absorption capacitor C_A and C_B and capacitance

The upper diagram shown on the next page is the flow of the counter EMF produced by the motor coils when it charges C_A and C_B and the lower diagram shows the direction of the energy discharged by C_A and C_B . When phase \bar{A} shown in the figure is off, the counter EMF (energy built-up by the coil inductance) produced by the motor coils passes through the path shown by the dotted lines and charges C_A and C_B . When phase \bar{A} is on, the energy stored by the capacitors are discharged in the direction shown by the dotted lines in the lower left diagram on the next page. The capacitors are discharged until the voltage across their pins equal the supply voltage V_{CC} . The peak voltage V_{SP} across the capacitors is given by the equation:

$$V_{SP} = \sqrt{\frac{L}{C}} \cdot I_o + V_{CC}$$

- where, L : Motor coil inductance between pins 4 and 5 or pins 18 and 17
- C : Capacitance of C_A and C_B
- I_o : Output current

An example waveform of V_{SP} is shown in the middle figure on the next page.

A V_{SP} that can be obtained when high voltage is applied can also be produced by using the counter EMF when the coil current rises.

Notes in selecting C_A and C_B .

- (1) V_{SP} must not exceed the breakdown voltage of the hybrid IC (70V).
- (2) C_A and C_B are charged/discharged in the same rate as the phase is switched. Hence, a capacitor with excellent anti-ripple characteristics should be selected.

SI-7230M

Application Note

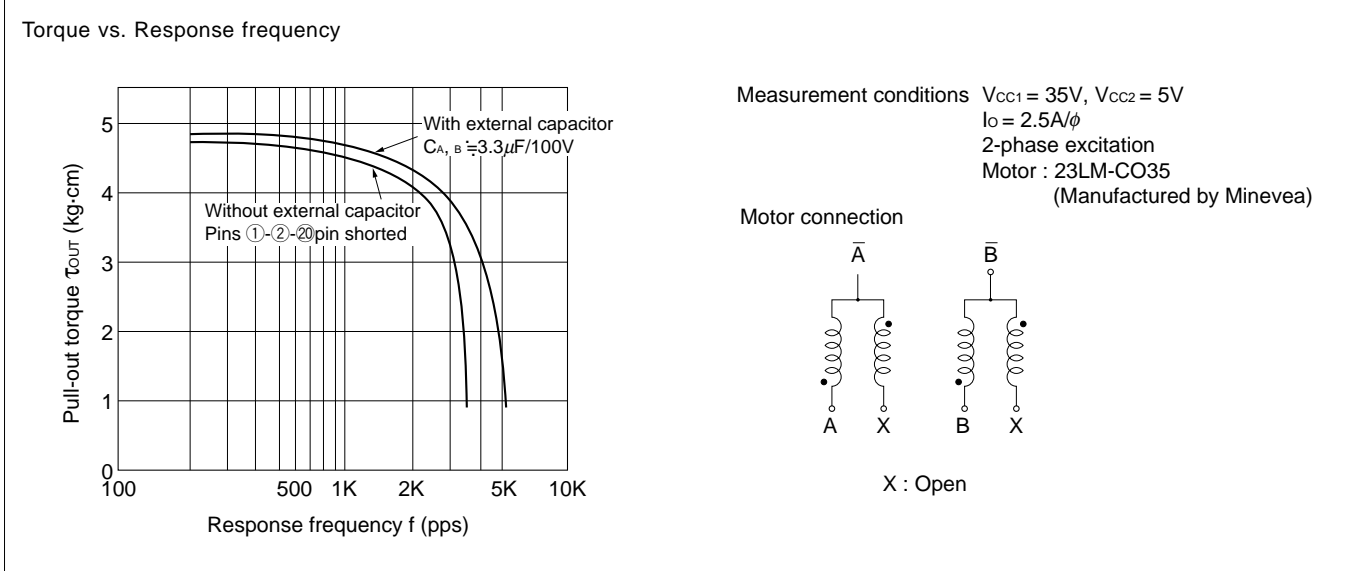
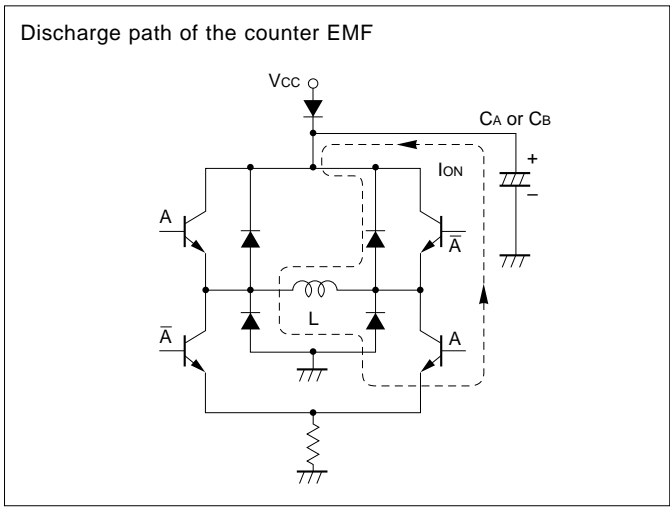
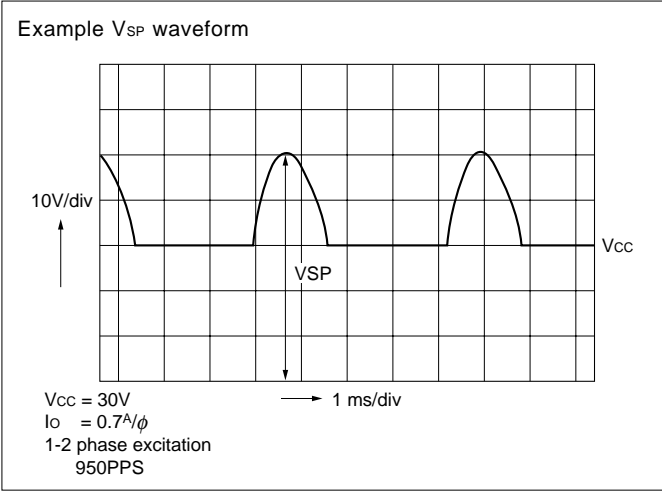
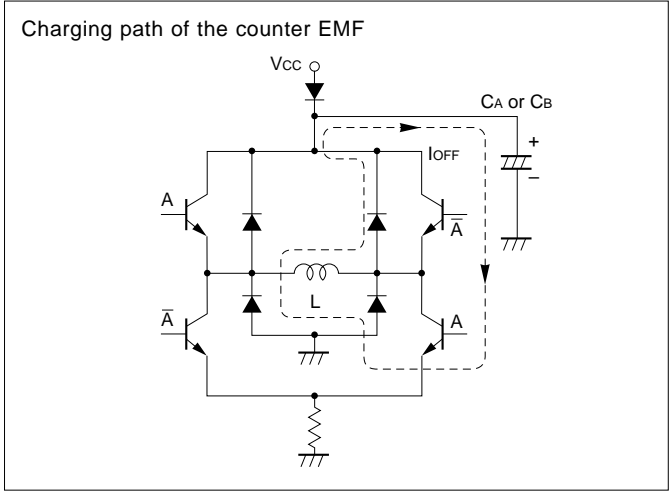

SI-7200M, SI-7230M, SI-7115B, SI-7300A, SI-7330A, SI-7500A and SI-7502

Handling Precautions

(Note: The SI-7502 is applicable for item (2) only.)

For details, refer to the relevant product specifications.

(1) Tightening torque:

The torque to be applied in tightening screws when mounting the IC on a heatsink should be below 49N•m.

(2) Solvent:

Do not use the following solvents:

Substances that dissolve the package	Chlorine-based solvents : Trichloroethylene, Trichloroethane, etc. Aromatic hydrogen compounds: Benzene, Toluene, Xylene, etc. Ketone and Acetone group solvents
Substances that weaken the package	Gasoline, Benzine and Kerosene

(3) Silicone grease:

The silicone grease to be used between the aluminum base plate of the hybrid IC and the heatsink should be any of the following:

- G-746 SHINETSU CHEMICAL INDUSTRIES CO., LTD.
- YG6260 TOSHIBA SILICONE CO., LTD.
- SC102 DOW CORNING TORAY SILICONE CO., LTD.

Please pay sufficient attention in selecting silicone grease since oil in some grease may penetrate the product, which will result in an extremely short product life.

Others

• Resistance against radiation

Resistance against radiation was not considered in the development of these ICs because it is assumed that they will be used in ordinary environment.