

# 5-phase Stepper Motor Star Connection Unipolar Driver IC

## SI-7500A

### ■ Ratings

(Ta = 25°C)

Type No.	Supply voltage (V)		Output current (A)	Junction temperature (°C)	Operating ambient temperature (°C)	Storage temperature (°C)
	Vcc	Vb	Io	Tj	Top	Tstg
SI-7500A	40	8	1.2	+125	-20 to +80	-30 to +100

### ■ Characteristics

(Ta = 25°C)

Type No.	Operating supply voltage (V)						Output current (mA/ø)			Power down Ratio (%)			Vb input current (mA)	External zener diode breakdown voltage (V)			*Input voltage (V)			*Input current (mA)		Trigger pulse voltage (V)		Trigger pulse time (µs)		Trigger pulse frequency (kHz)	
	Vcc		Vb		Io		Iopd/Io			Ib	Vz		VIH1	VIH2	VIL	IiH1	IiH2	Vtrig	Ttrig	Ftrig							
	min	typ	max	min	typ	max	min	typ	max	min	typ	max	min	max	min	max	min	max	min	max	min	typ	typ	max	min	max	
SI-7500A	17	24	30	4.5	5	5.5	200	750	1000	35	50	100	15	Vcc x1.5	50	3.9	1.3	0.6	0.21	0.22	4.0	Vb	1.0	2.0	20	25	

### ■ Block diagram

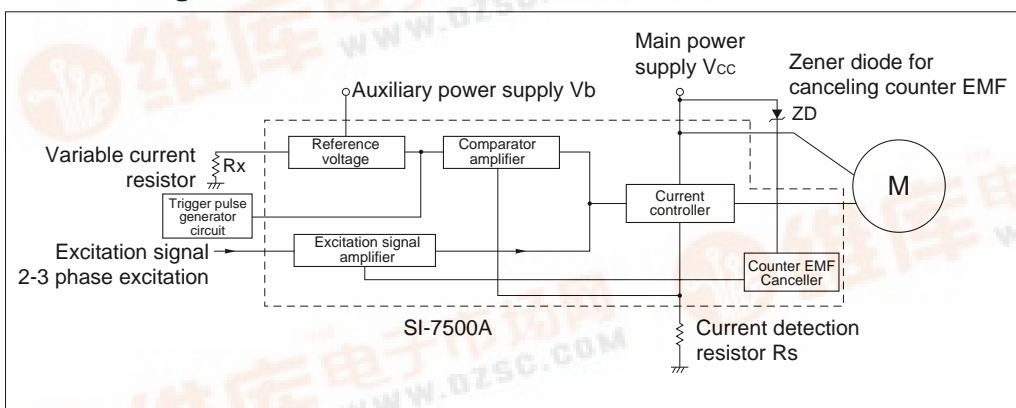

\* Input voltage and input current conditions

- VIH1 : Vb = 5V, Q1 to Q5ON  
Rx = ∞, IIN = 0.2mA
- VIH2 : Vb = 5V, Q1 to Q5OFF,  
IIN = 0.22mA
- IiH1 : Vb = 5V, Q1 to Q5ON,  
VIN = 3.7V
- IiH2 : Vb = 5V, Q1 to Q5OFF,  
VIN = 0.9V

### ■ Equivalent circuit diagram

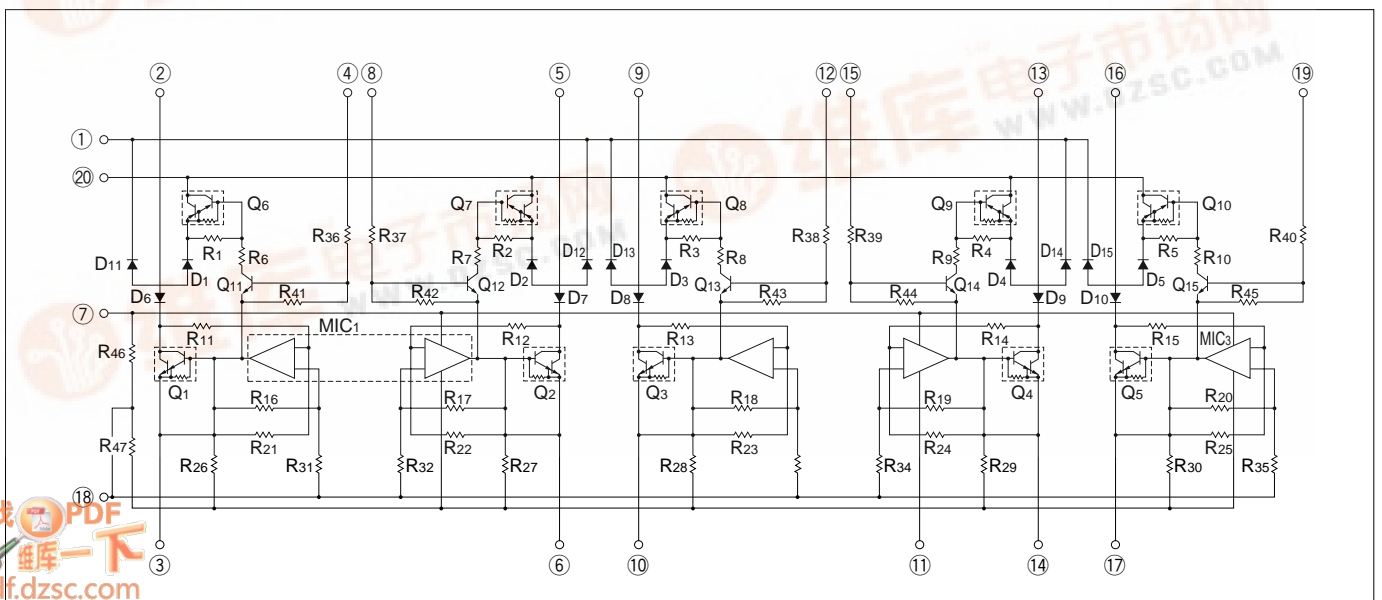

# SI-7500A

## ■ Diagram of external circuits

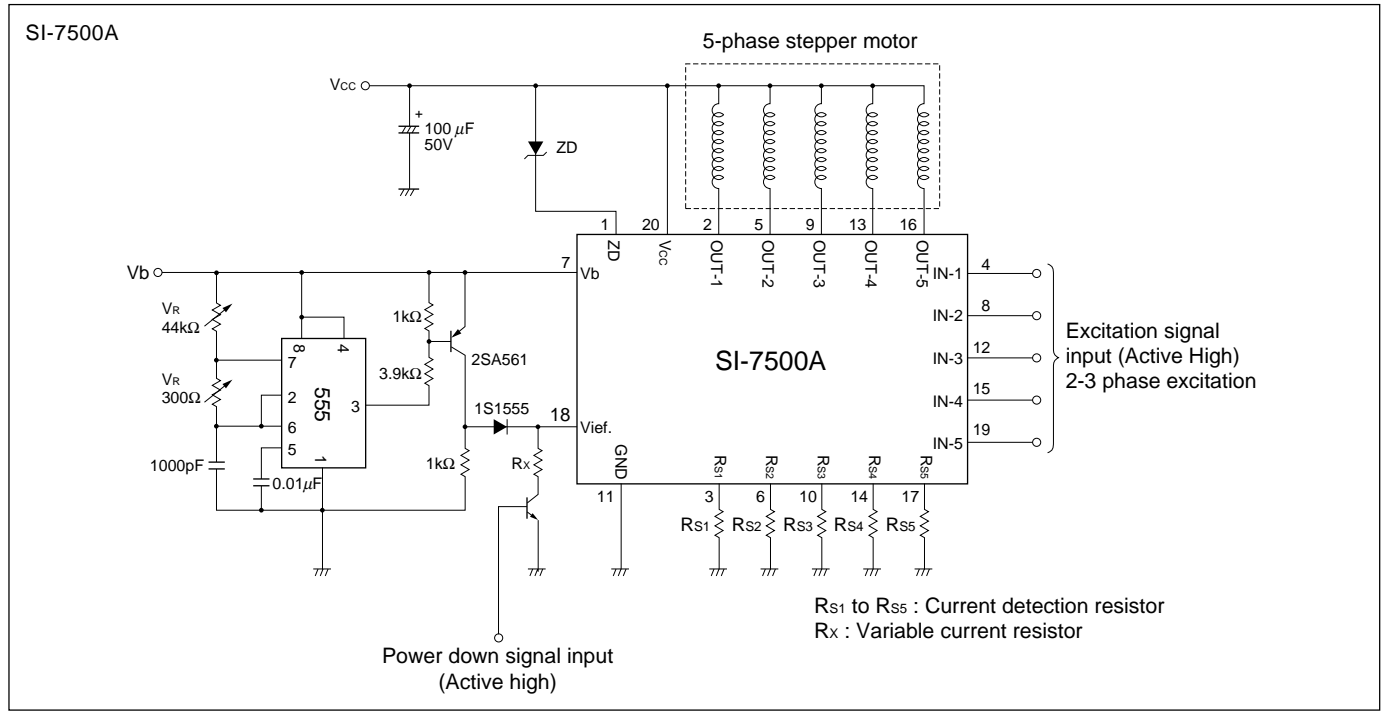

## ■ External dimensions

(Unit: mm)

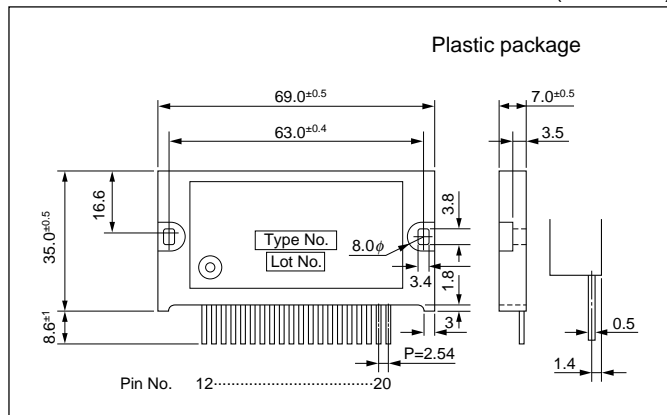

## ■ Supply voltage vs. Output current

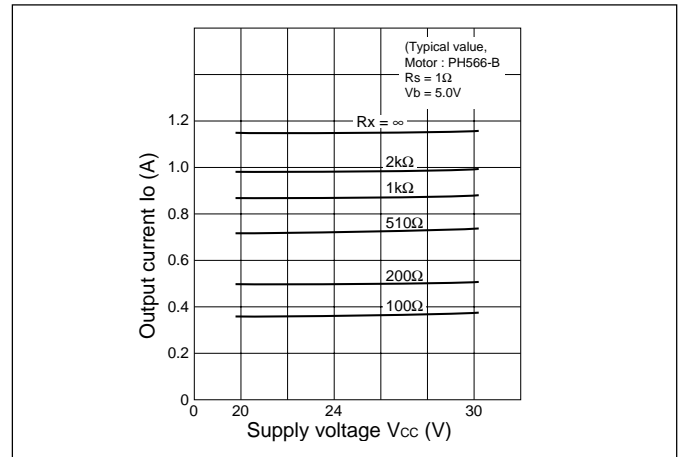

## ■ Case temperature vs. Output current

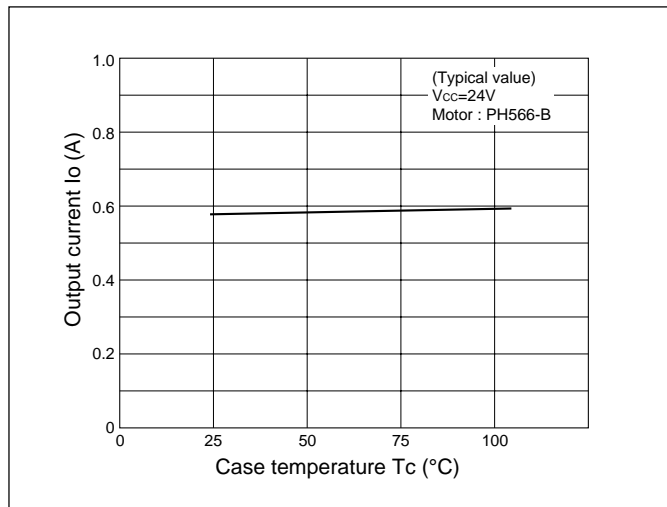

## ■ Torque characteristics

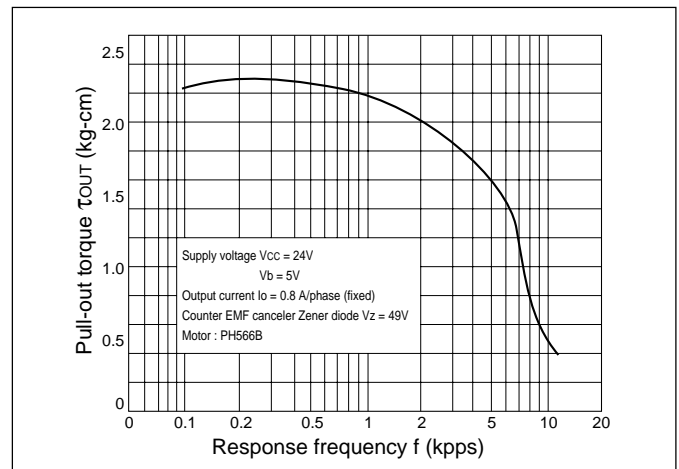

# SI-7500A

## Application Note

### ■ Determining the output current $I_{OH}$ (motor coil current)

The main elements that determine the output current are Current detection resistor  $R_s$ , Supply voltage  $V_b$ , and Variable current resistor  $R_x$ .

#### (1) Normal mode

To operate a motor at maximum current level, set  $R_x$  to infinity (open).

From Fig. A, when the maximum output current ripple is designated as  $I_{OH}$ , its value will be,

$$I_{OH} = \frac{V_{RSH}}{R_s} \dots\dots\dots [A]$$

$V_{RSH}$  can be computed as follows:

$$V_{RSH} = 0.2 V_b + 0.213 \text{ (center value)} \dots\dots\dots [B]$$

From equations [A] and [B], the output current  $I_{OH}$  can be computed as follows:

$$I_{OH} = \frac{I}{R_s} (0.2 V_b + 0.213)$$

The relationship between  $I_{OH}$  and  $R_s$  is shown in Fig. B.

#### (2) Power down mode

When an external resistor  $R_x$  is connected,  $V_{RSH}$  changes as shown in the Fig. B even when  $R_s$  is retained. Obtain the power down output current  $I_{OH\text{PD}}$  from Fig. B and equation [A].

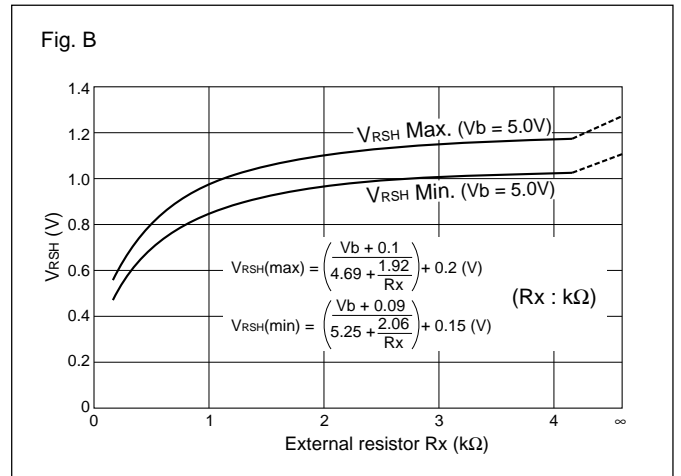
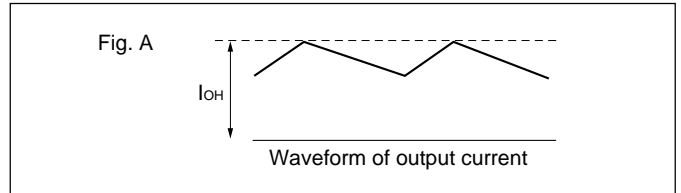

### ■ Thermal design

Obtain the internal power dissipation that corresponds to the output current to be required from Fig. C, multiply this by three, and determine the size of the heatsink from the derating curve in Fig. D. The derating curve is based on junction temperature of 125°C. However, make some allowance so that  $T_c$  is 85°C or less and then select the proper heatsink size.

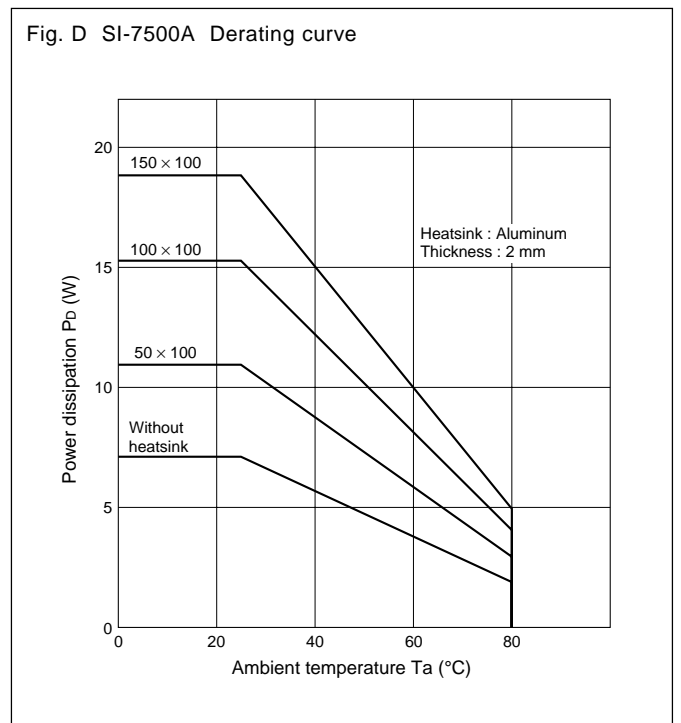
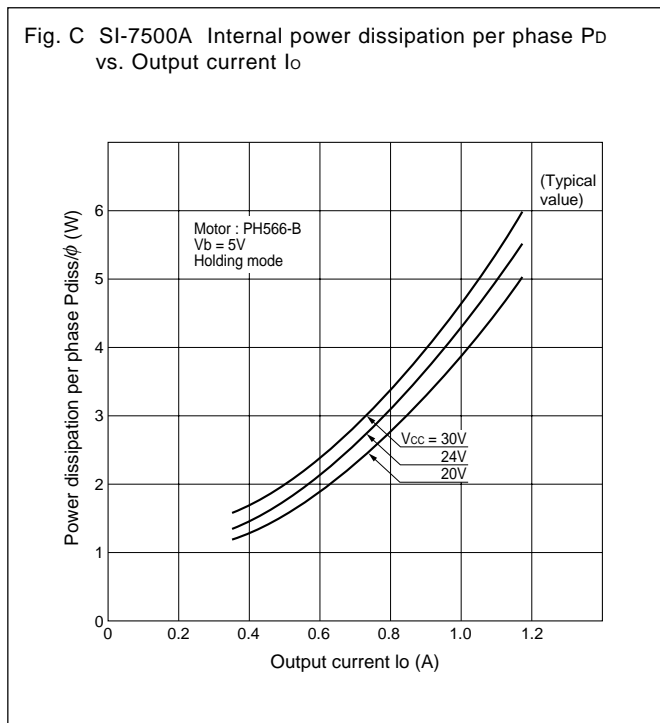

# SI-7200M, SI-7230M, SI-7115B, SI-7300A, SI-7330A, SI-7500A and SI-7502

## Handling Precautions

(Note: The SI-7502 is applicable for item (2) only.)

For details, refer to the relevant product specifications.

### (1) Tightening torque:

The torque to be applied in tightening screws when mounting the IC on a heatsink should be below 49N•m.

### (2) Solvent:

Do not use the following solvents:

Substances that dissolve the package	Chlorine-based solvents : Trichloroethylene, Trichloroethane, etc. Aromatic hydrogen compounds: Benzene, Toluene, Xylene, etc. Ketone and Acetone group solvents
Substances that weaken the package	Gasoline, Benzine and Kerosene

### (3) Silicone grease:

The silicone grease to be used between the aluminum base plate of the hybrid IC and the heatsink should be any of the following:

- G-746 SHINETSU CHEMICAL INDUSTRIES CO., LTD.
- YG6260 TOSHIBA SILICONE CO., LTD.
- SC102 DOW CORNING TORAY SILICONE CO., LTD.

Please pay sufficient attention in selecting silicone grease since oil in some grease may penetrate the product, which will result in an extremely short product life.

## Others

### • Resistance against radiation

Resistance against radiation was not considered in the development of these ICs because it is assumed that they will be used in ordinary environment.