



SL1018

FM IF SYSTEM

Description

The SL1018 has versatile muting characteristics and allows receiver designers to realize the muting performance according to their design concept.

Functions

- FM IF Amplifier/Limiter
- Quadrature Detector
- AFC Clamp
- AGC Drive
- AF Mute Amplifier
- Signal Meter Drive
- DC Level Detector

Features

- Adjustable muting sensitivity
- Soft muting function
- Variable maximum muting attenuation (6dB~40dB)
- Variable muting slope with respect to input signal level
- High limiting sensitivity with muting off
- Good S/N ratio
- Clamped AFC output
- Delayed AGC output for front end circuit
- Recommended supply voltage: $V_{CC} = 8V$
- Operating supply voltage range: $V_{CC} = 7.5V \sim 16V$
- Low distortion
- Good AMR

Application

- FM car stereo receiver

Ordering Information

Type NO.	Marking	Package Code
SL1018	SL1018	ZIP16

Outline Dimensions

unit : mm

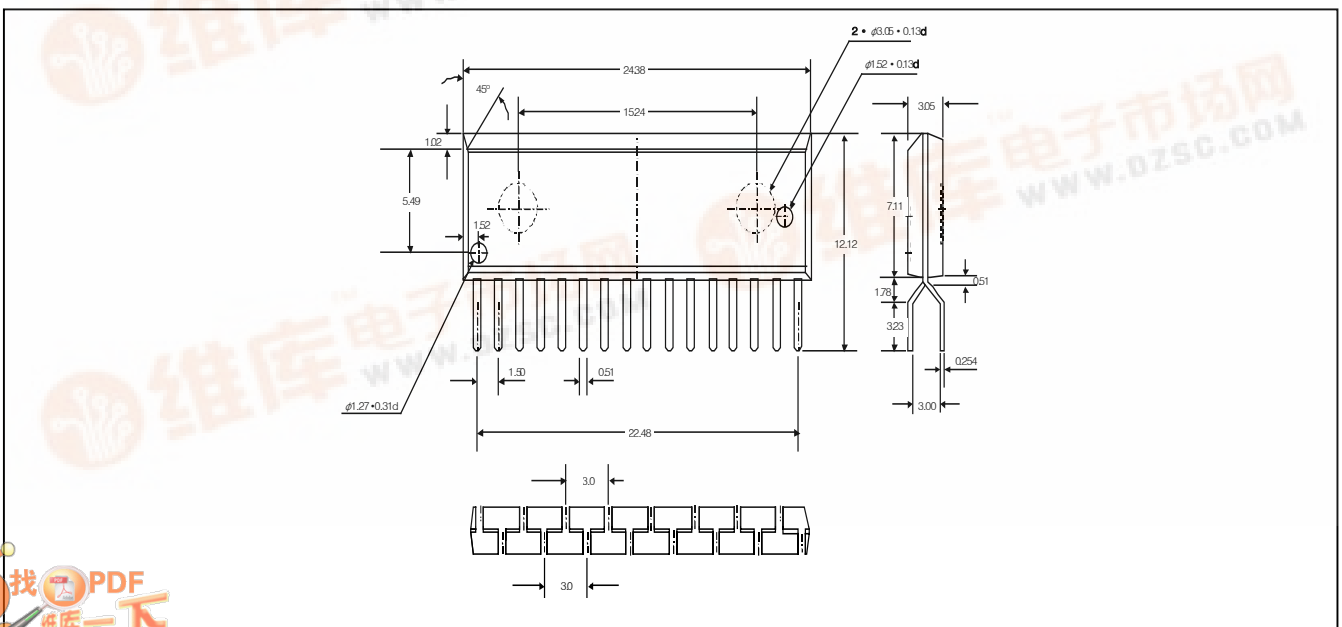

Absolute Maximum Ratings

(Ta = 25°C)

Characteristics	Symbol	Rating	Unit
Supply Voltage	V _{CC}	16	V
Supply Current	I _{CC}	40	mA
Power Dissipation	P _D	640	mW
Operation Temperature	T _{opr}	- 20 ~ + 70	°C
Storage Temperature	T _{stg}	- 40 ~ + 125	°C

Block Diagram

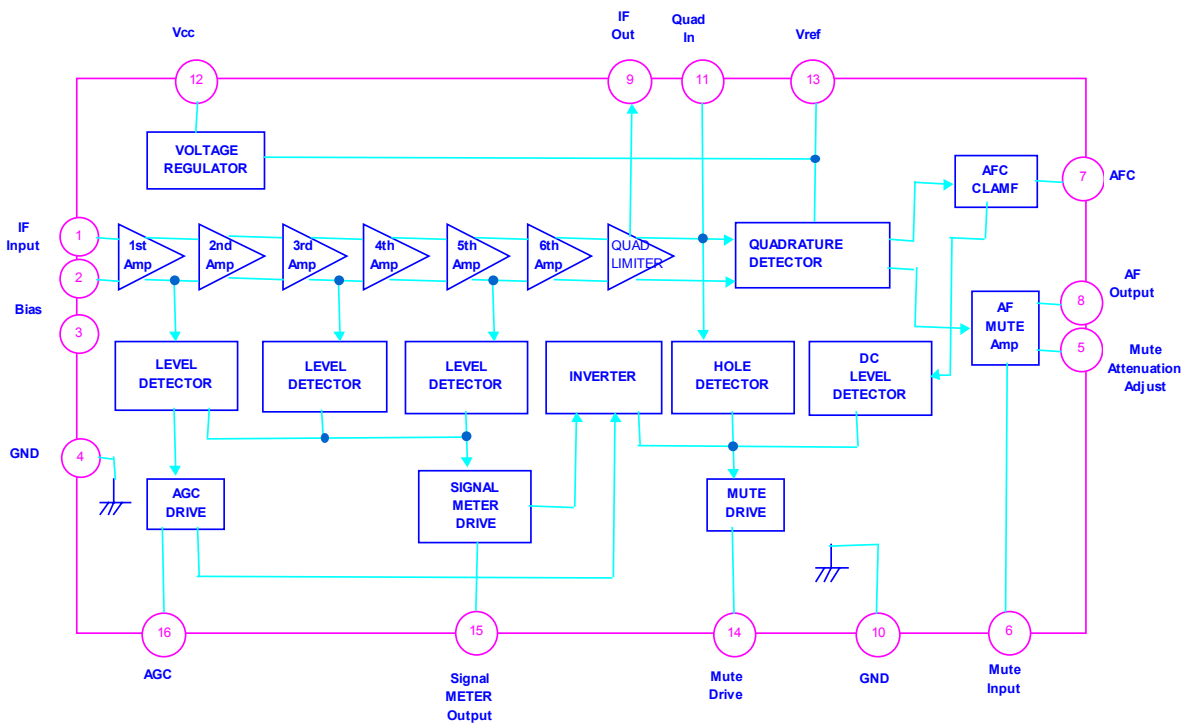

Test Circuit

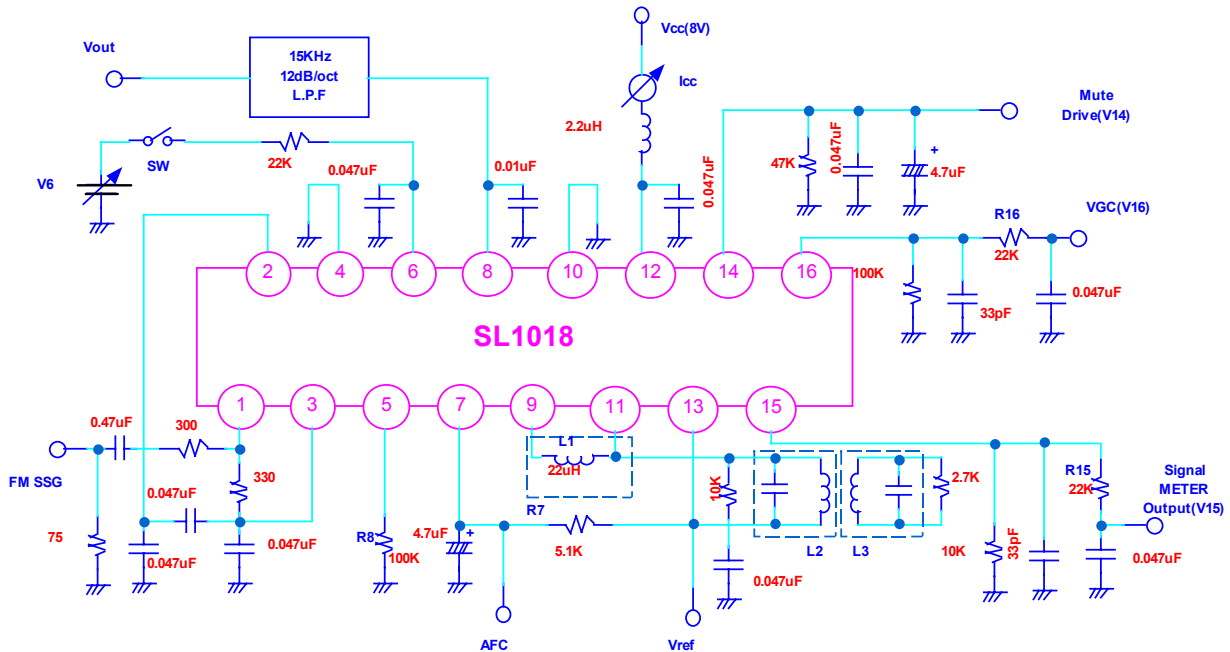

Electrical Characteristics

(Unless otherwise specified, $T_a = 25^\circ\text{C}$, $V_{cc} = 8\text{V}$, $f = 10.7\text{MHz}$, $V_{IN} = 100\text{dB}\mu$, $f_m = 400\text{Hz}$, $\Delta f = \pm 75\text{kHz}$)

Characteristics	Symbol	Test Condition	Min.	Typ.	Max.	Unit
Quiescent Current	I_{CCQ}	Quiescent	15	21	27	mA
Supply Current	I_{CC}	—	20	25	30	mA
Detector Output Level	V_{OD}	—	200	260	320	mVrms
Input Limiting Sensitivity	$V_{IN}(\text{lim})$	$V_{OD} = 3\text{dB down}$	—	25	29	dB μ
Muting Sensitivity	$V_{IN}(\text{mute})$	$V_{14} = 2\text{V}$	22	26	32	dB μ
Total Harmonic Distortion	THD	—	—	0.05	0.2	%
Signal to Noise Ratio	S/N	—	72	78	—	dB
Muting Attenuation (1)	M_{A1}	$V_6 = 2\text{V} (22\text{k}\Omega)$	10	15	20	dB
Muting Attenuation (2)	M_{A2}	$V_6 = 5\text{V} (22\text{k}\Omega)$	24	28	32	dB
Muting Bandwidth	M_{BW}	$V_{14} = 2\text{V}$	140	210	370	kHz
AM Rejection Ratio	AMR	AM 1kHz 30% mod	50	63	—	dB
Signal Meter Output 1	V_{SM1}	Quiescent	0	0.1	0.3	V

Electrical Characteristics(continued)

Characteristics	Symbol	Test Condition	Min.	Typ.	Max.	Unit
Signal Meter Output 2	V_{SM2}	$V_{IN} = 50dB\mu$	0.8	1.4	2	V
Signal Meter Output 3	V_{SM3}	$V_{IN} = 70dB\mu$	1.6	2.4	3.2	V
Signal Meter Output 4	V_{SM4}	$V_{IN} = 100dB\mu$	4.5	5.3	6	V
Muting Drive Output 1	V_{MD1}	Quiescent	3.5	4.2	5	V
Muting Drive Output 2	V_{MD2}	$V_{IN} = 100dB\mu$	0	0	0.3	V
AGC Output 1	$V_O (AGC)1$	Quiescent	3.5	4.1	4.5	V
AGC Output 2	$V_O (AGC)2$	$V_{IN} = 100dB\mu$	0	0.02	0.3	V
Offset Voltage 1	V_{OS1}	Quiescent, Pin 7 to 13	-0.25	0	+0.25	V
Offset Voltage 2	V_{OS2}	Quiescent, Pin 8 to 13	-0.5	0	+0.5	V

Information On Muting Characteristics

The muting operation is performed by an AF mute amplifier, the gain of which decreases with the increased gain control current applied to the pin 6. (The control current is supplied by a muting drive circuit and change continuously the gain of an AF mute amplifier) But the gain does not decrease further when the control current reaches approximately $120 \mu A$ or higher. The lower limit of the gain under this condition depends on a resistor connected between the pin5 and the ground. And the more the resistance increases, the more the gain decreases. Thus the maximum attenuation will be set by connecting the resistor between the pin5 and the ground. Fig.1 shows the muting attenuation with different R_5 between the pin5 and the ground.

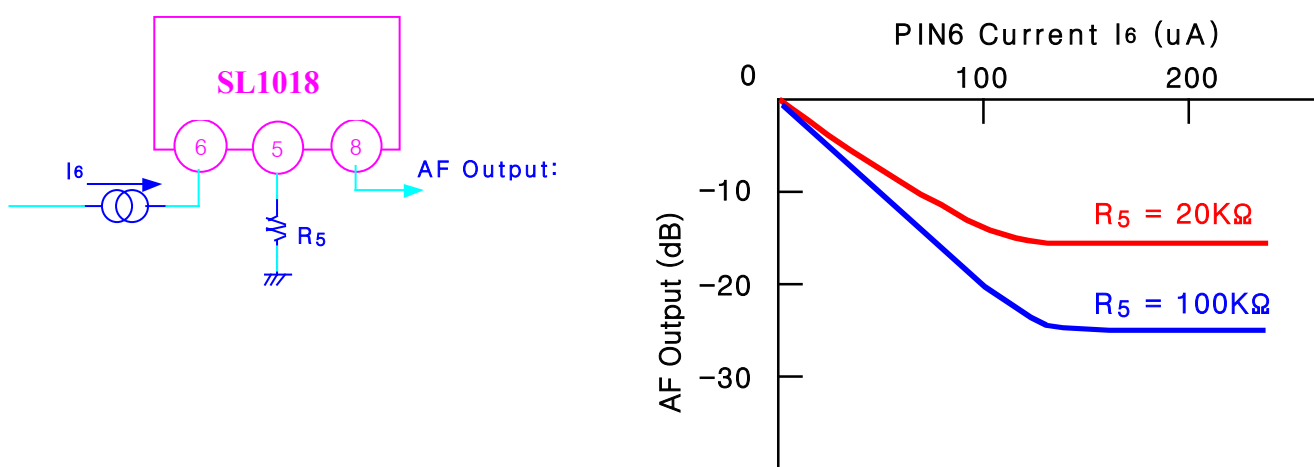

- Fig. 1 -

Information On Muting Characteristics (continued)

Since the pin6 is connected to the base of the emitter ground transistor through a protection resistor of 500Ω in series as shown Fig.2. the voltage between pin6 and ground is about 0.7V when the control current is applied. Actually, the muting operation is accomplished by applying a muting drive output voltage(pin14) to the pin6 through a high resistance($20k\Omega$)

The muting drive output is composed of three output devices:

- ① Hole Detector output which develops a voltage when C/N (carrier-to-noise ratio) is lower than weak signal input conditions.
- ② A reversed output of the signal meter drive output.
- ③ A bandwidth limited muting drive output which develops a voltage when the AFC output becomes higher than $\pm V_{BE}$ during tuning-off operation. All these output are led to an OR circuit and the output is developed at pin14.

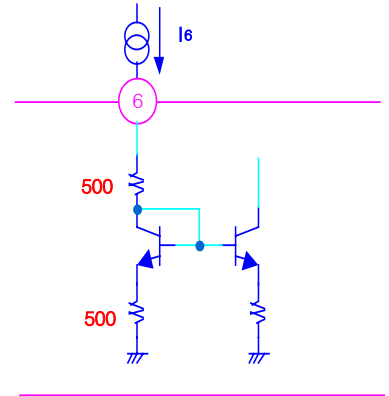

- Fig. 2-

The inverted output of the signal meter drive output is obtained as shown Fig. 3.

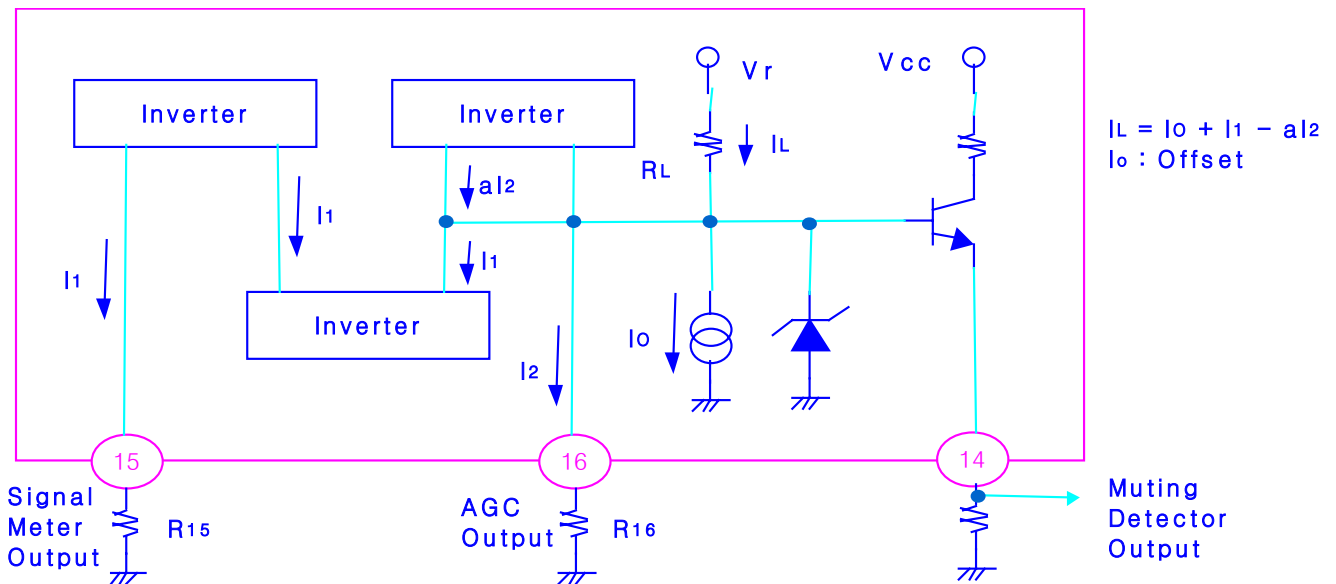

-Fig. 3-

By Fig. 3, V_{14} is given by $V_{14} = V_r - (I_0 + I_1 - aI_2)R_L - V_{BE}$. Conditions are $V_r=4.9V$, $I_0 \cong 0.2$ mA, $a \cong 2$, $R_L=22k\Omega$, $V_{BE}=0.7V$, $I_1=V_{15}/R_{15}$, $I_2=V_{16}/R_{16}$, where V_{16} is a constant equal to 4.1V(Typ.) for medium or lower signal input levels where the muting drive output is required. Since the V_{15} increase proportionally to the increase of the input signal level, I_1 will also increase, and the V_{14} will decrease. Thus the required muting drive output can be obtained by selecting proper values of R_{15} and R_{16} . Increasing R_{15} makes the slope of the curve for the muting drive output vs. antenna signal input decrease, or decreasing the R_{15} increase the slope of the curve.

Information On Muting Characteristics (continued)

Furthermore, varying the value of a resistor connected between the pin14 and pin16 changes the value of the muting control current required to obtain the same muting drive output, accordingly a slope of curve for muting attenuation vs. antenna signal input level is also changed. Fig. 4 shows these characteristics investigated by using an actual receiver.

The method to adjust the muting circuit is to set the signal input level required to actuate the muting circuit with the R_{16} , to adjust the slope of the curve for the muting attenuations vs. antenna signal input with the R_{15} and to adjust the maximum muting attenuation determined by setting the noise level at no signal.

The slope of the curve for the muting attenuation vs. antenna signal input level can also be adjusted by the resistor connected between the pin14 and the pin6. However, if the resistor is too high, the muting control current does not flow into pin6 over than $120 \mu\text{A}$ even though the maximum muting drive output (V_{14}) is applied, namely the muting attenuation doesn't reach its maximum value. A recommended value of the resistor between the pin14 and the pin6 is about $22\text{k}\Omega$.

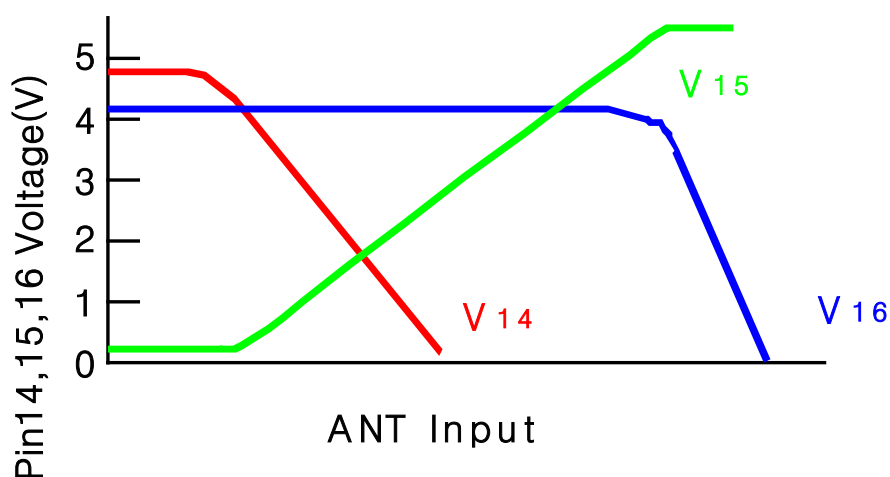

-Fig.4-

Typical Performance Characteristics

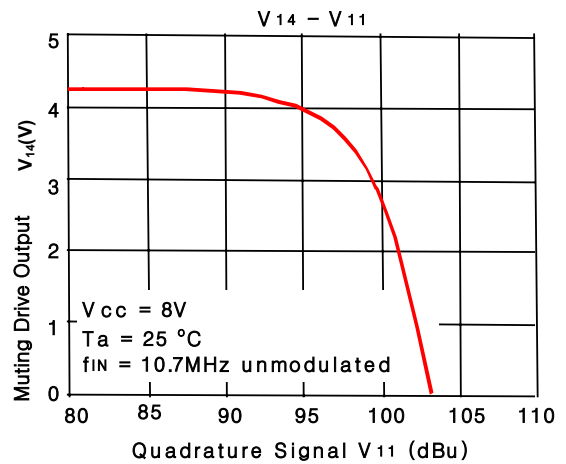
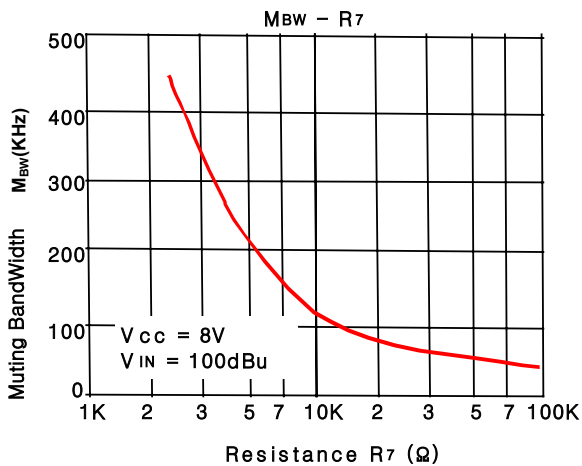
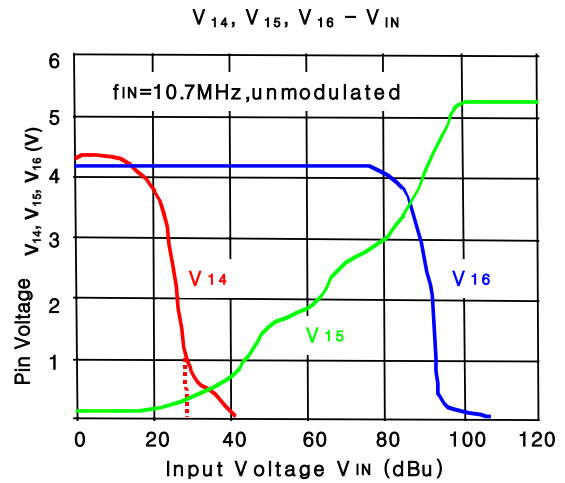
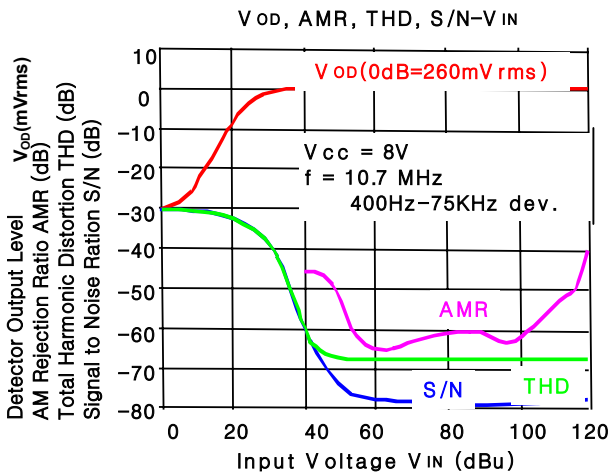
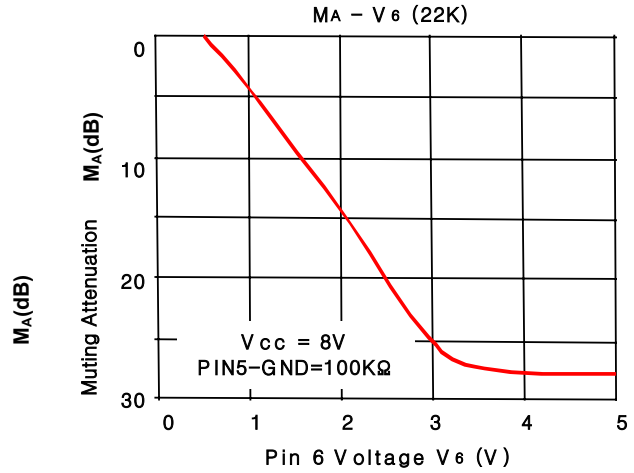
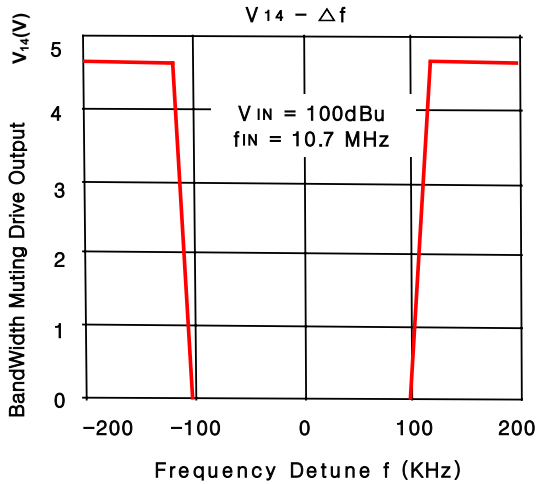

Typical Performance Characteristics (continued)

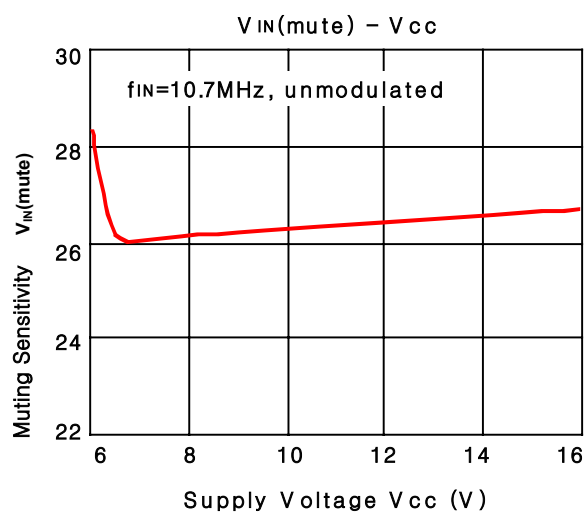
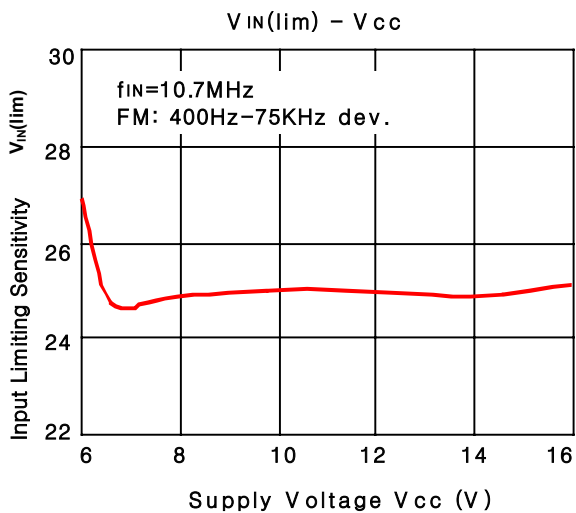
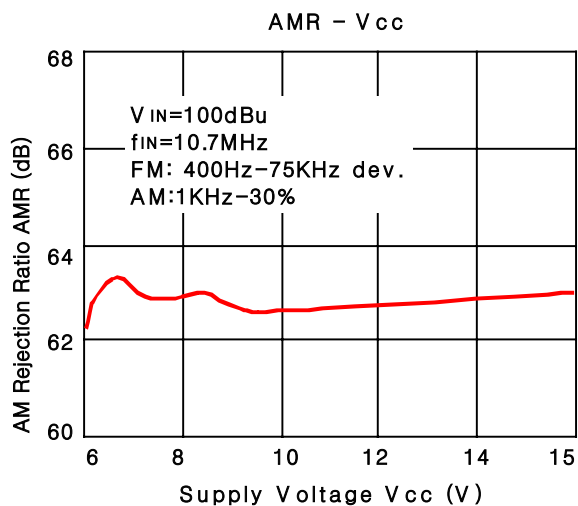
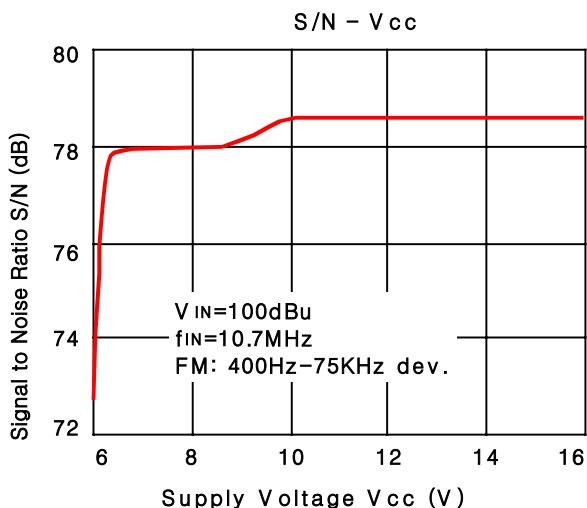
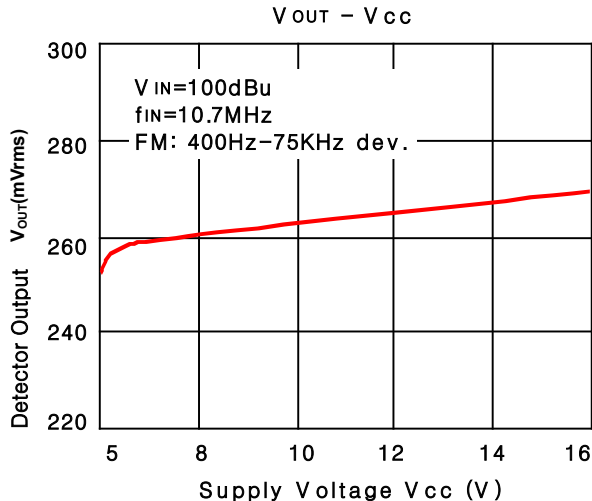
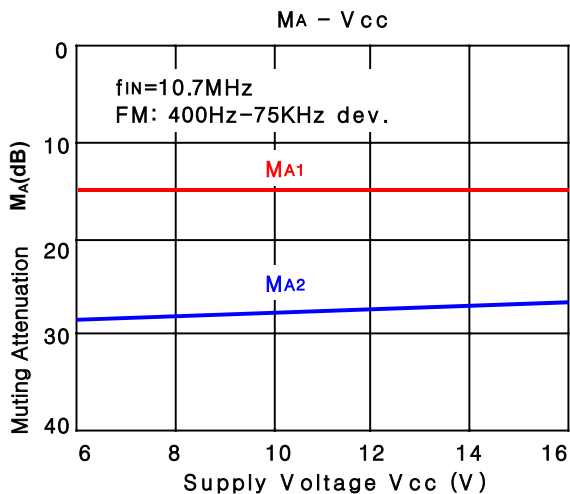

Application circuit

