



SL531

250MHz TRUE LOG IF AMPLIFIER

The SL531 C is a wide band amplifier designed for use in logarithmic IF amplifiers of the true log type. The input and log output of a true log amplifier are at the same frequency i e detection does not occur. In successive detection log amplifiers (using SL521 SL1521 types) the log output is detected.

The small signal gain is 10dB and bandwidth is over 500MHz. At high signal levels the gain of a single stage dropstounity. A cascade of such stages give a close approximation to a log characteristic at centre frequencies between 10and 200MHz.

An important feature of the device is that the phase shift is nearly constant with signal level. Thus any phase information on the input signal is preserved through the strip.

The device is also available as the 5962-92084 which has guaranteed operation over the full Military Temperature Range and is screened to MIL-STD-883 Class B. Data is available separately

FEATURES

- Low Phase Shift vs Amplitude
- On-Chip Supply Decoupling
- Low External Components Count

APPLICATIONS

- True Log Strips with:-
- Log Range 70dB
 - Centre frequencies 10 - 200MHz
 - Phase Shift ± 0.5 degrees / 10dB

ABSOLUTE MAXIMUM RATINGS (Non-simultaneous)

Supply voltage	+12 volts
Storage temperature range	-65°C to +150°C
Operating temperature range	-55°C to +125°C
	See operating notes
Max junction temperature	175°C
Junction - ambient thermal resistance	220°C/Watt
Junction - case thermal resistance	80°C/Watt

CIRCUIT DESCRIPTION

The SL531 transfer characteristic has two regions For small input signals it has a nominal gain of 10 dB. at large signals the gain falls to unity (see Fig 7) This is achieved by operating a limiting amplifier and a unity gain amplifier in parallel (see Fig 3) Tr1 and Tr4 comprise the long tailed pair limiting amplifier, the tail current being supplied by Tr5, see Fig 2 Tr2 and Tr3 form the unity gain amplifier the gain of which is defined by the emitter resistors The outputs of both stages are summed in the 300 ohm resistor and Tr7 acts as an emitter follower output buffer. Important features are the amplitude and phase linearity of the unity gain stage which is achieved by the use of 5GHz transistors with carefully optimised geometries.

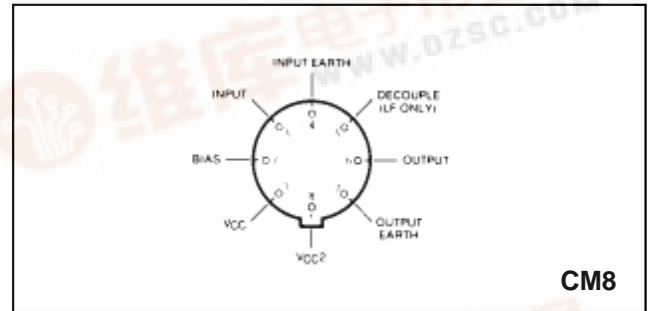

Fig.1 Pin connections

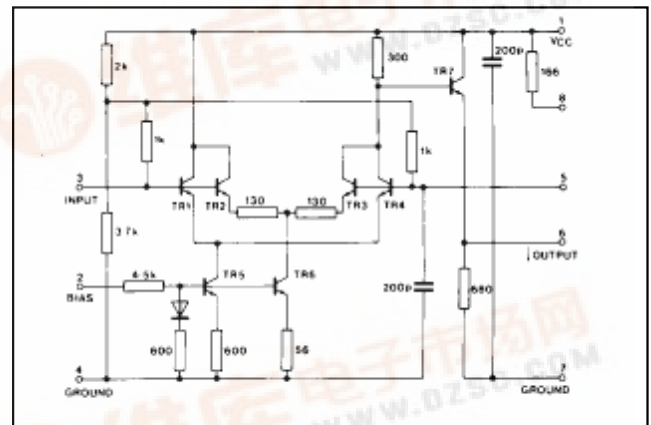

Fig.2 Circuit diagram

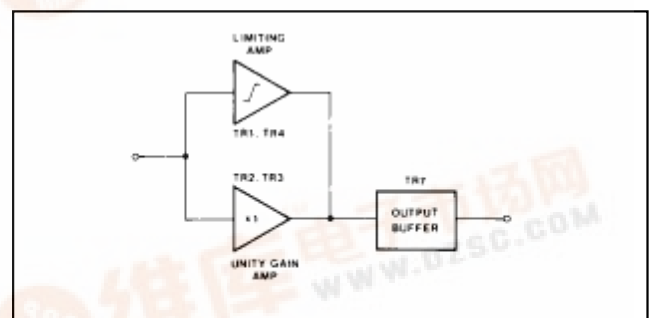

Fig.3 Block diagram

ORDERING INFORMATION

5962-92084 (SMD)
SL531 C CM



SL531

ELECTRICAL CHARACTERISTICS

These characteristics are guaranteed over the following conditions (unless otherwise stated)

- Test circuit Fig (4)
- Frequency 60MHz
- Supply voltage 9 volts
- Ambient temperature 22±2°C

Characteristic	Value			Units	Conditions
	Min.	Typ.	Max.		
Small signal voltage gain	8	10	12	dB	Vin = -30dBm
High level slope gain	-1	0	+1	dB	
Upper cut off frequency	250	500		MHz	
Lower cut off frequency		3	10	MHz	-3dB w.r.t. ± 60MHz
Supply current		17	25	mA	
Phase change with input amplitude		1.1	3	degrees	-Vin = 30dBm to +10dBm
Input impedance	2.pF parallel with 1kΩ				
Output impedance	15Ω series with 25nH				f = 10 - 200MHz

OPERATING NOTES

1. Supply Voltage Options

An on chip resistor is provided which can be used to drop the supply voltage instead of the external 180 ohms shown in the test circuit. The extra dissipation in this resistor reduces the maximum ambient operating temperature to 100°C. It is also possible to use a 6 volt supply connected directly to pins 1 and 2 Problems with feedback on the supply line etc may occur in this connection and RF chokes may be required in the supply line between stages.

2. Layout P recautions

The internal decoupling capacitors help prevent high frequency instability however normal high frequency layout precautions are still necessary. Coupling capacitors should be physically small and be connected with short leads. It is most important that the ground connections are made with short leads to a continuous ground plane.

3. Low Frequency Response

The LF response is determined by the on chip capacitors. It can be extended by extra external decoupling on pins 5 and 1.

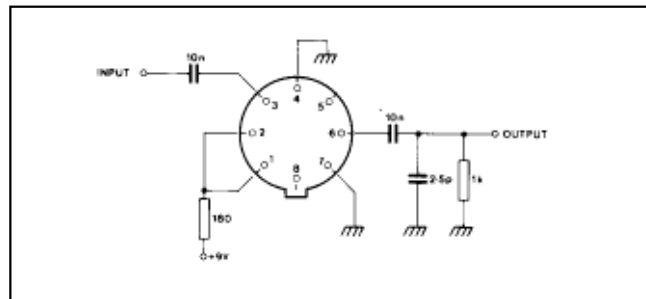

Fig.4 Test circuit

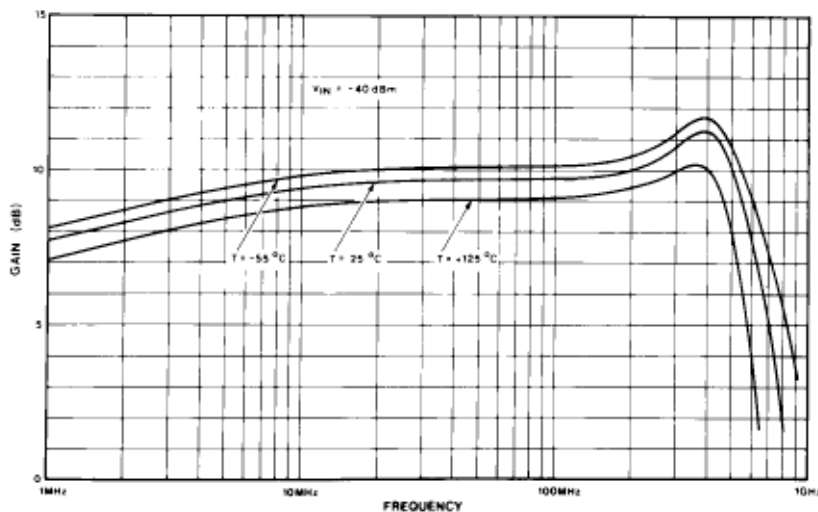

Fig.5 Small signal frequency response

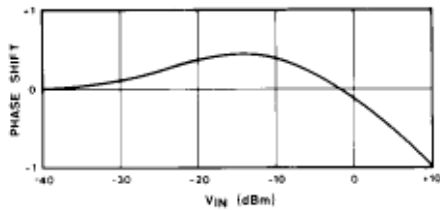

Fig.6 Phase v. input

TYPICAL APPLICATION—6 STAGE LOG STIP

- Input log range 0dBm to—70dBm
- Low level gain 60dB (—70dBm in)
- Output dynamic range 20dB
- Phase shift (over log range) $\pm 3^\circ$
- Frequency range 10—200MHz

The circuit shown in Fig 9 is designed to illustrate the use of the SL531 in a complete strip. The supply voltage is fed to each stage via an external 180Ω resistor to allow operation to 125°C ambient. If the ambient can be limited to +100°C then the internal resistor can be used to reduce the external component count. Interstage coupling is very simple with just a capacitor to isolate bias levels being necessary. No connection is necessary to pin 5 unless operation below 10MHz is required. It is important to provide extra decoupling on pin 1 of the first stage to prevent positive feedback occurring down the supply line. An SL560 is used as a unity gain buffer the output of the log strip being attenuated before the SL560 to give a nominal 0dBm output into 50Ω.

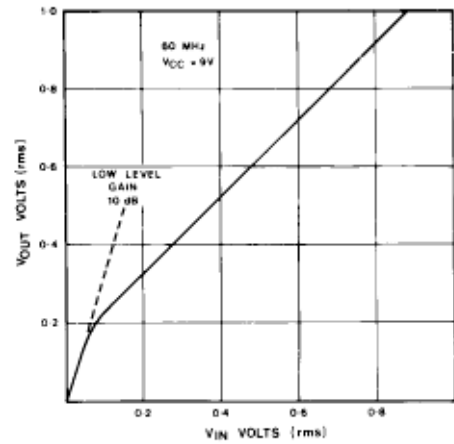

Fig.7 Transfer characteristics linear plot

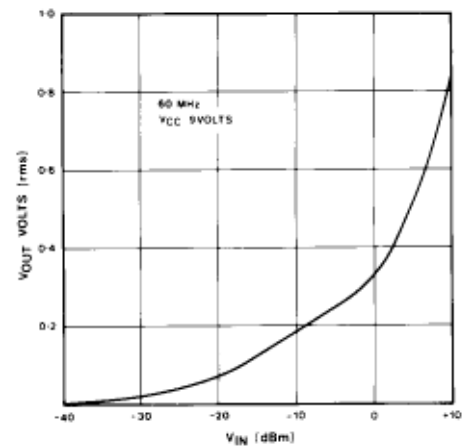

Fig.8 Transfer characteristics logarithmic input scale

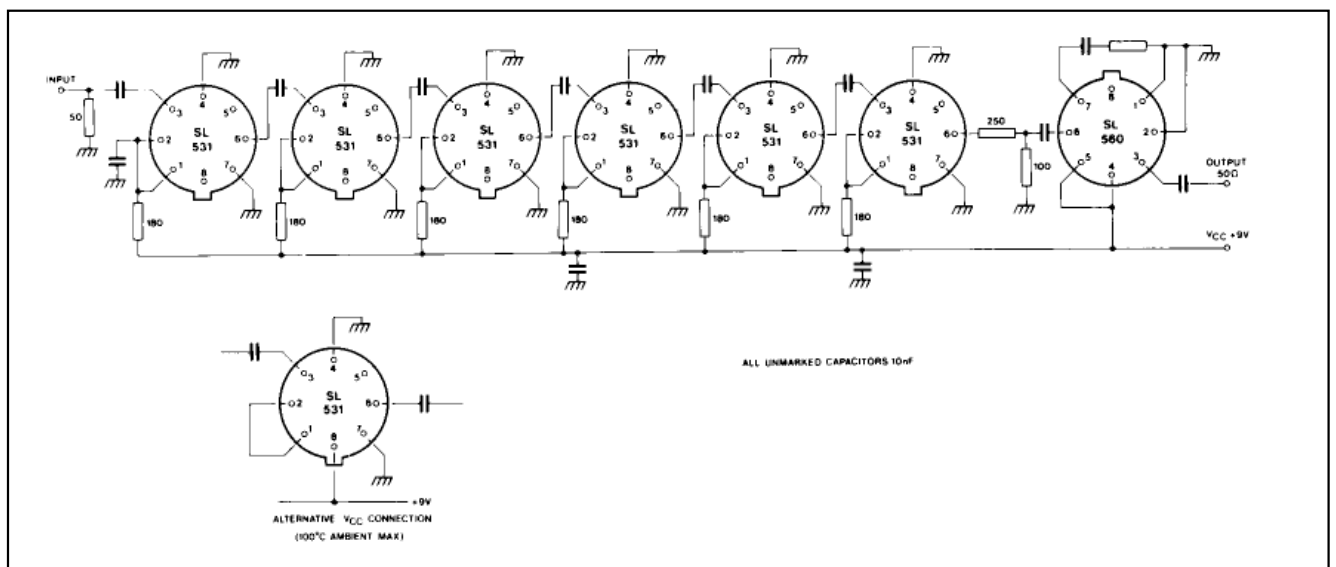

Fig.9 Circuit diagram 6 stage strip

SL531



HEADQUARTERS OPERATIONS

GEC PLESSEY SEMICONDUCTORS

Cheney Manor, Swindon,
Wiltshire SN2 2QW, United Kingdom.
Tel: (0793) 518000
Fax: (0793) 518411

GEC PLESSEY SEMICONDUCTORS

P.O. Box 660017
1500 Green Hills Road,
Scotts Valley, California 95067-0017,
United States of America.
Tel: (408) 438 2900
Fax: (408) 438 5576

CUSTOMER SERVICE CENTRES

- **FRANCE & BENELUX** Les Ulis Cedex Tel: (1) 64 46 23 45 Fax : (1) 64 46 06 07
- **GERMANY** Munich Tel: (089) 3609 06-0 Fax : (089) 3609 06-55
- **ITALY** Milan Tel: (02) 66040867 Fax: (02) 66040993
- **JAPAN** Tokyo Tel: (03) 5276-5501 Fax: (03) 5276-5510
- **NORTH AMERICA** Scotts Valley, USA Tel (408) 438 2900 Fax: (408) 438 7023.
- **SOUTH EAST ASIA** Singapore Tel: (65) 3827708 Fax: (65) 3828872
- **SWEDEN** Stockholm, Tel: 46 8 702 97 70 Fax: 46 8 640 47 36
- **UK, EIRE, DENMARK, FINLAND & NORWAY**
Swindon Tel: (0793) 518510 Fax : (0793) 518582

These are supported by Agents and Distributors in major countries world-wide.

© GEC Plessey Semiconductors 1994

This publication is issued to provide information only which (unless agreed by the Company in writing) may not be used, applied or reproduced for any purpose nor form part of any order or contract nor to be regarded as a representation relating to the products or services concerned. No warranty or guarantee express or implied is made regarding the capability, performance or suitability of any product or service. The Company reserves the right to alter without prior knowledge the specification, design or price of any product or service. Information concerning possible methods of use is provided as a guide only and does not constitute any guarantee that such methods of use will be satisfactory in a specific piece of equipment. It is the user's responsibility to fully determine the performance and suitability of any equipment using such information and to ensure that any publication or data used is up to date and has not been superseded. These products are not suitable for use in any medical products whose failure to perform may result in significant injury or death to the user. All products and materials are sold and services provided subject to the Company's conditions of sale, which are available on request.