



Obsolescence Notice

This product is obsolete.

This information is available for your convenience only.

For more information on Zarlink's obsolete products and replacement product lists, please visit http://products.zarlink.com/obsolete_products/

***THIS DOCUMENT IS FOR MAINTENANCE
PURPOSES ONLY AND IS NOT
RECOMMENDED FOR NEW DESIGNS***

SL6659

LOW POWER IF/AF CIRCUIT (WITH RSSI) FOR FM RADIO

The SL6659 is a complete single chip mixer, IF amplifier and detector for FM cellular radio, cordless telephones and low power radio applications. It features an exceptionally stable RSSI (Received Signal Strength Indicator) output using a unique system of detection. Supply current is less than 2mA from a supply voltage in the range 2.5V to 7.5V.

FEATURES

- Low Power Consumption (1.5mA)
- Single Chip Solution
- Guaranteed 200MHz Operation
- Exceptionally Stable RSSI

APPLICATIONS

- Cellular Radio Telephones
- Cordless Telephones

ORDERING INFORMATION

SL6659 NA MP – Miniature plastic DIL package
SL6659 NA MPTD - As above, supplied on tape and reel

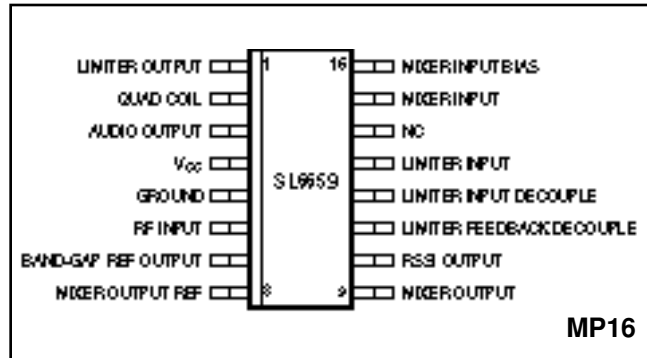

Fig. 1 Pin connections – top view

QUICK REFERENCE DATA

- Supply Voltage: 2.5V to 7.5V
- Sensitivity: 3µV
- Co-channel Rejection: 7dB

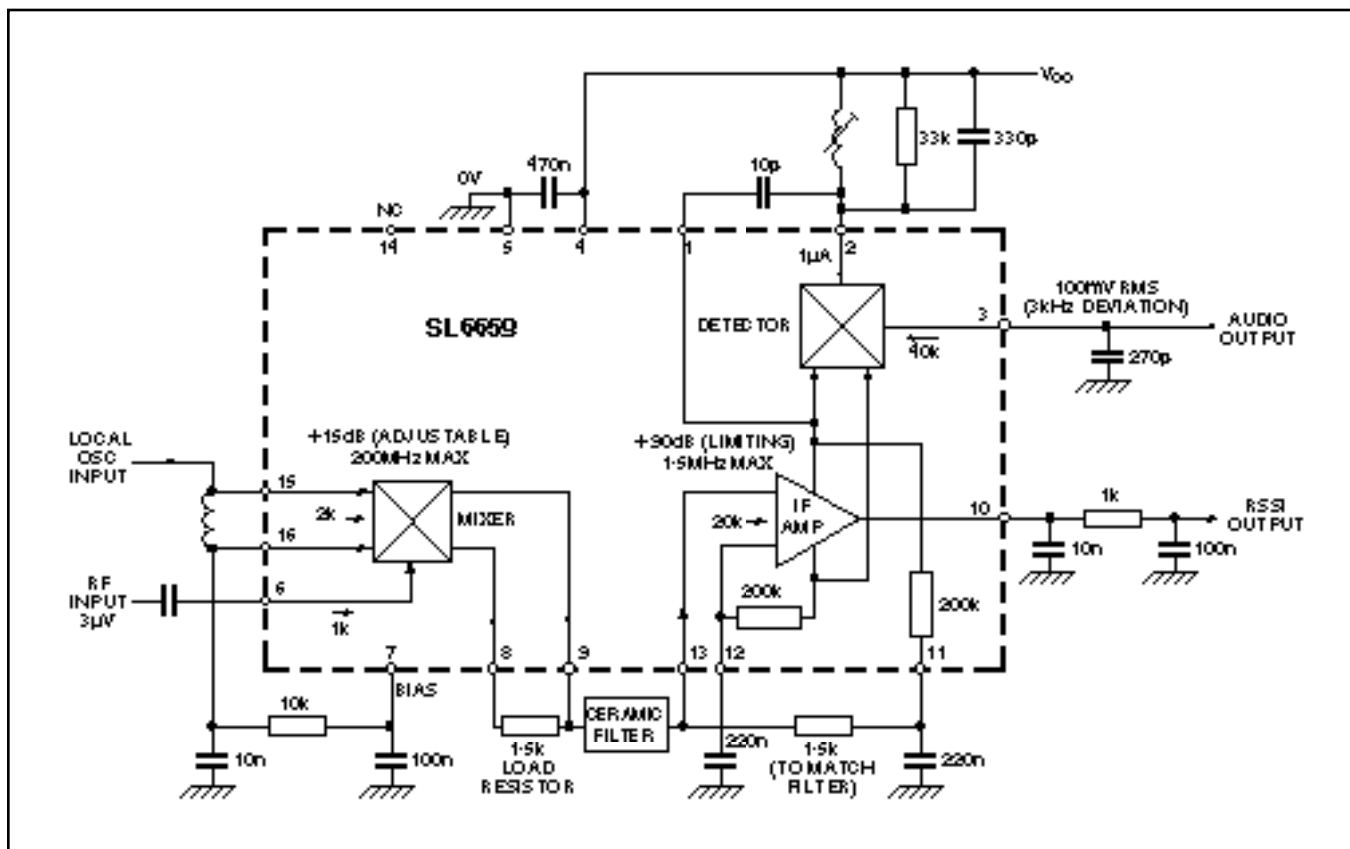

Fig. 2 Block diagram

ABSOLUTE MAXIMUM RATINGS

Supply voltage	8V
Storage temperature	-55°C to +150°C
Mixer input	1Vrms

NOTE: This device has static sensitive inputs, sensitivity typically measured as 500V using MIL-STD-883 method 3015. Therefore, ESD handling precautions are essential to avoid degradation of performance or permanent damage of this device.

ELECTRICAL CHARACTERISTICS

The characteristics are guaranteed over the following conditions, unless otherwise stated:

$$V_{CC} = 2.5V \text{ to } 7.5V, T_{AMB} = -30^{\circ}C \text{ to } +85^{\circ}C, IF = 455kHz, RF = 50MHz, \text{ Quad Coil working } Q = 30$$

Characteristic	Value			Units	Conditions
	Min.	Typ.	Max.		
Overall					
Supply current		1.5	2.0	mA	20dB SINAD
Sensitivity		5		μV	12dB SINAD
		3		μV	RF input <500 μV
AM rejection		40		dB	$T_{AMB} = 25^{\circ}C$
V_{BIAS}	1.0	1.2	1.4	V	See Note 2
Co-channel rejection		7		dB	
Mixer					
RF input impedance		1		k	
LO input impedance		2		k	
LO input bias		5		μA	At V_{BIAS}
Mixer gain		15		dB	$R_{LOAD} = 1.5k$
3rd order input intercept		-10		dBm	
LO input level	180		300	mV	
LO frequency	200			MHz	
IF Amplifier					
Gain		90		dB	
Frequency	455	1500		kHz	
Differential input impedance		20		k	
Detector					
Audio output level	75		125	mV	} 5mV into pin 13
Ultimate S/N ratio		60		dB	
THD		0.5	5	%	
Output impedance		40		k	
RSSI Output ($T_{AMB} = +25^{\circ}C$)					
Output current			25	μA	No input pin13
	50		80	μA	Pin 13 = 2.5mV
Current change	0.9	1.22	1.5	$\mu A/dB$	See Note 1
Linear dynamic range	70			dB	See Note 1

NOTES

- The RSSI output is 100% dynamically tested at 5V and +20°C over a 70dB range. First the input to pin 13 is set to 2.5mV and the RSSI current recorded. Then for each step of 10dB from -40 to +30db, the current is measured. The current change in each step must meet the specified figure for current change. The RSSI output is guaranteed monotonic and free from discontinuities over this range.
- Co-channel rejection is measured by applying a 3kHz deviation, 1kHz modulated signal at an input level to give a 20dB SINAD ratio. Then a 3kHz deviation 400Hz modulated signal on the same frequency is also applied and its level increased to degrade the SINAD to 14dB.

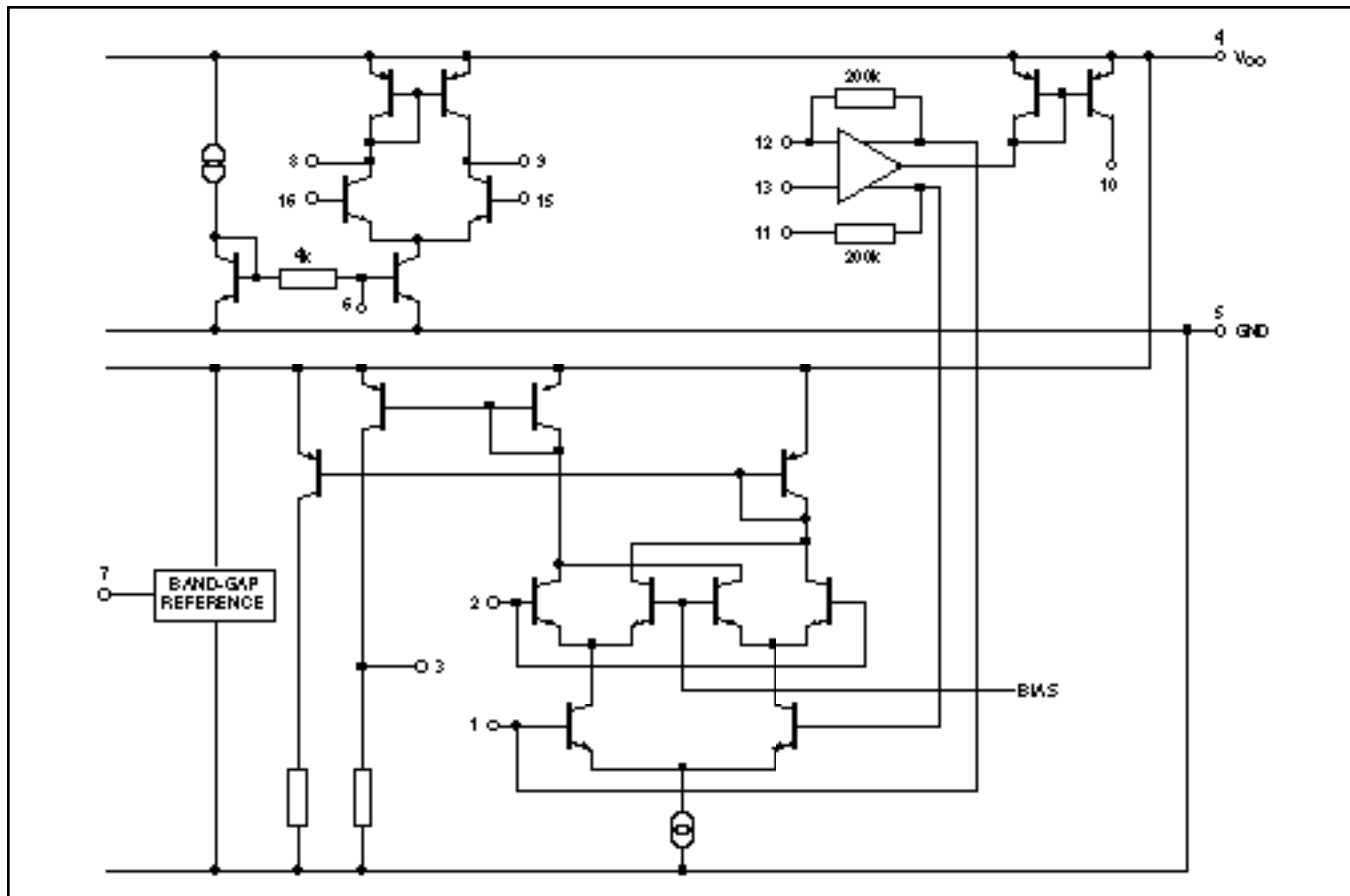

Fig. 3 Internal schematic

GENERAL DESCRIPTION

The SL6659 is a very low power, high performance integrated circuit intended for IF amplification and demodulation in FM radio receivers. It comprises:

- A mixer stage for use up to 200MHz
- A limiting amplifier operating up to 1.5MHz
- A quadrature detector with AF output
- An RSSI (Received Signal Strength Indicator) output

Mixer

The Mixer is single balanced with an active load. Gain is set externally by the load resistor, although the value is normally determined by that required for matching into the ceramic filter. It is possible to use a tuned circuit but an increase in mixer gain will result in a corresponding reduction of the mixer input intercept point.

The RF input is a diode-biased transistor with a bias current of typically 300µA. The LO input is differential but would normally be driven single-ended. Special care should be taken to avoid accidental overload of the local oscillator input.

IF Amplifier

The limiting amplifier is capable of operation to at least 1MHz and the input impedance is set by an external resistor to match the

ceramic filter. Because of the high gain, pins 11 and 12 must be adequately bypassed.

Detector

A conventional quadrature detector providing audio output is fed internally from the IF amplifier; the quadrature input is fed externally using an appropriate capacitor and phase shift network.

RSSI Output

The RSSI output is a current source with value proportional to the logarithm of the IF signal amplitude. There is a small residual current due to noise within the amplifier (and mixer) but beyond this point there is a measured and guaranteed 70dB dynamic range. The typical range extends to 92dB, independent of frequency, and with exceptionally good temperature and supply voltage stability.

Supply Voltage

The SL6659 will operate reliably from 2.5V to 7.5V. The supply line must be decoupled with 470nF using short leads.

Internal Bias Voltage

The internal band-gap reference must be externally decoupled. It can be used as an external reference but must not be loaded heavily; the output impedance is typically 14 ..

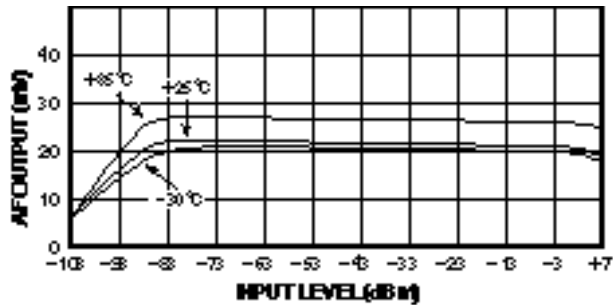

Fig. 4 Audio output v. input and temperature at 2.5V

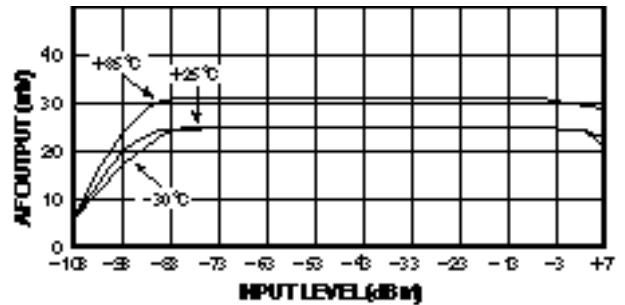

Fig. 5 Audio output v. input and temperature at 5.0V

Fig. 6
FreeHand 3.11
20/5/94 18:08

Fig. 6 Audio output v. input and temperature at 7.5V

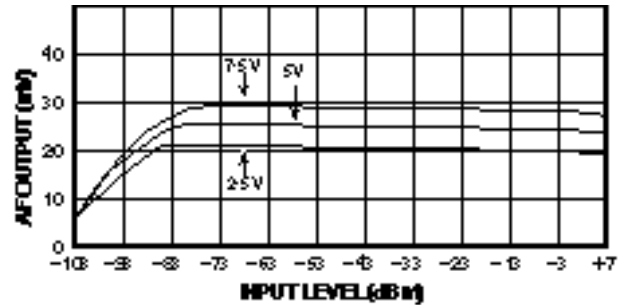

Fig. 7 Audio output v. input and supply voltage at +25°C

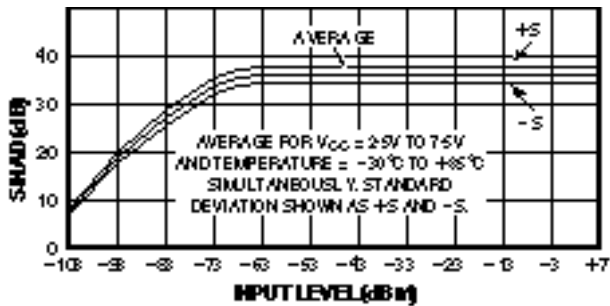

Fig. 8 SINAD v. input level

Fig. 9
FreeHand 3.11
20/5/94 18:09

Fig. 9 AM rejection and input level



Fig. 10 RSSI output v. input and supply voltage
($T_{AMB} = 20^{\circ}C$)



Fig. 11 RSSI output v. input and temperature
($V_{CC} = 2.5V$)



Fig. 12 RSSI output v. input level and temperature
($V_{CC} = 5V$)



Fig. 13 RSSI output v. input level and temperature
($V_{CC} = 7.5V$)

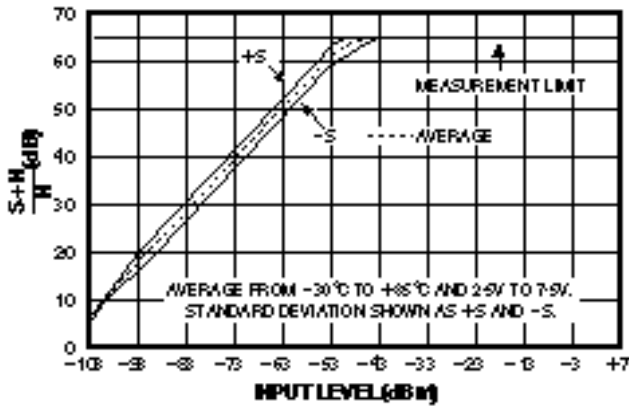

Fig. 14 (Signal+noise) to noise ratio v. input level

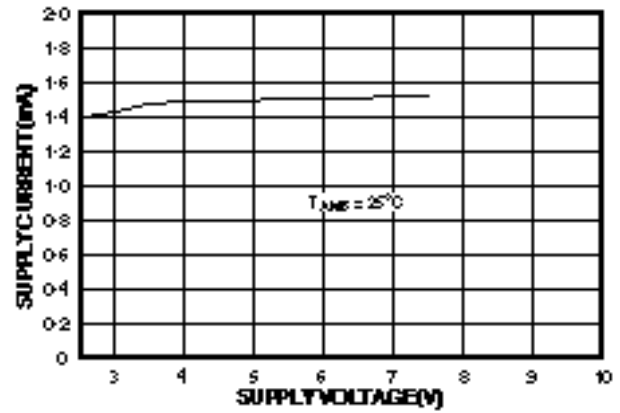

Fig. 15 Supply current v. supply voltage

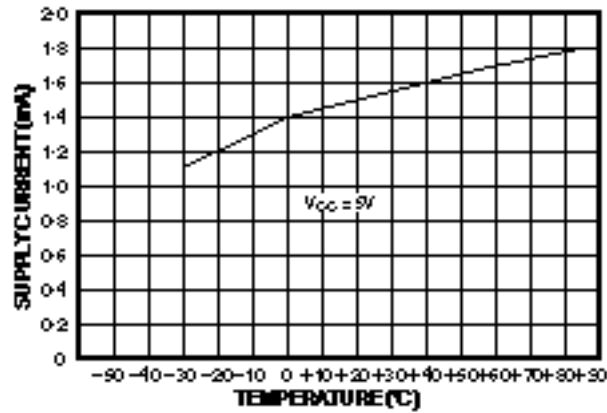

Fig. 16 Supply current v. temperature

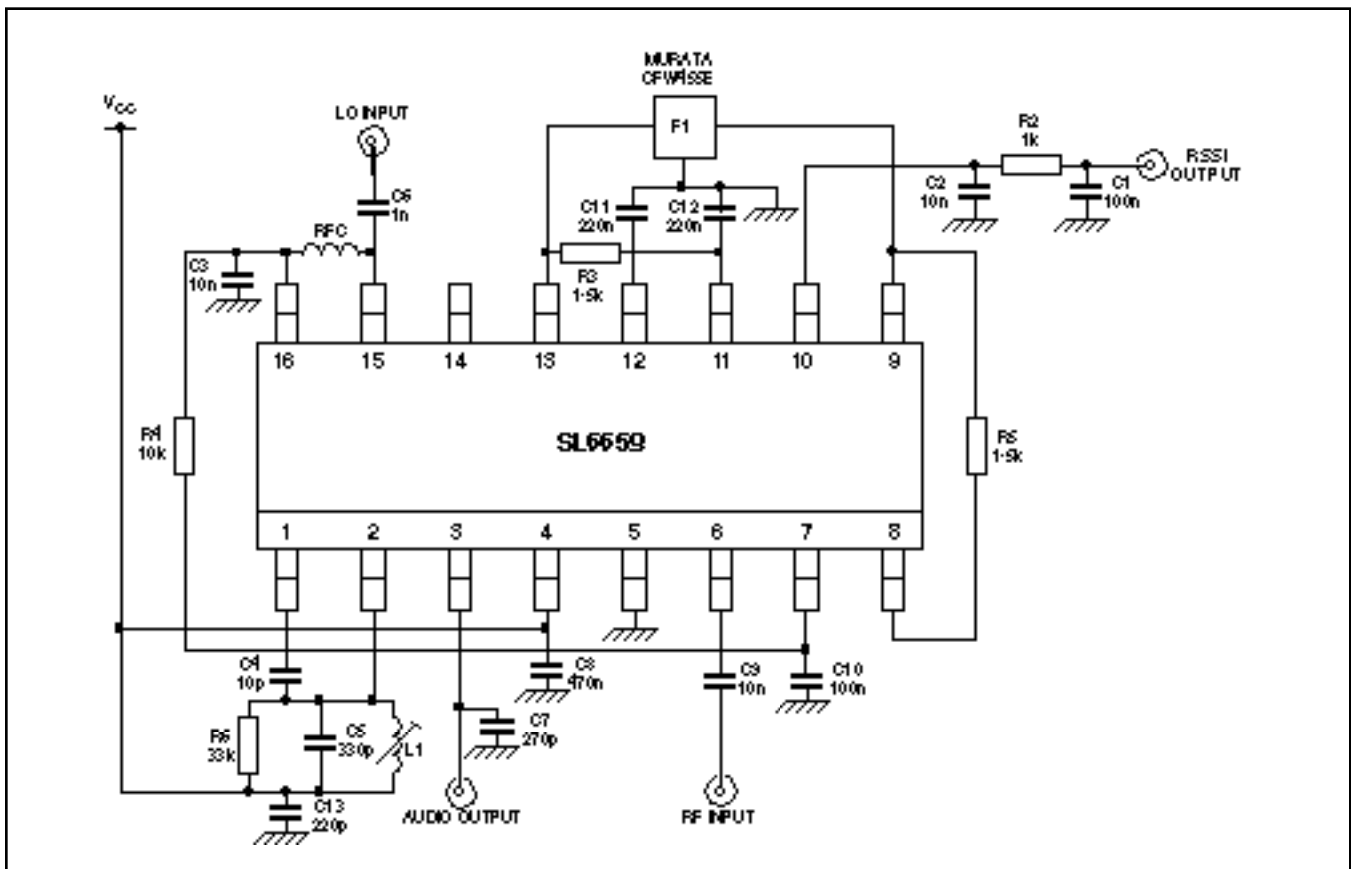

Fig. 17 Circuit diagram of SL6659 demonstration board

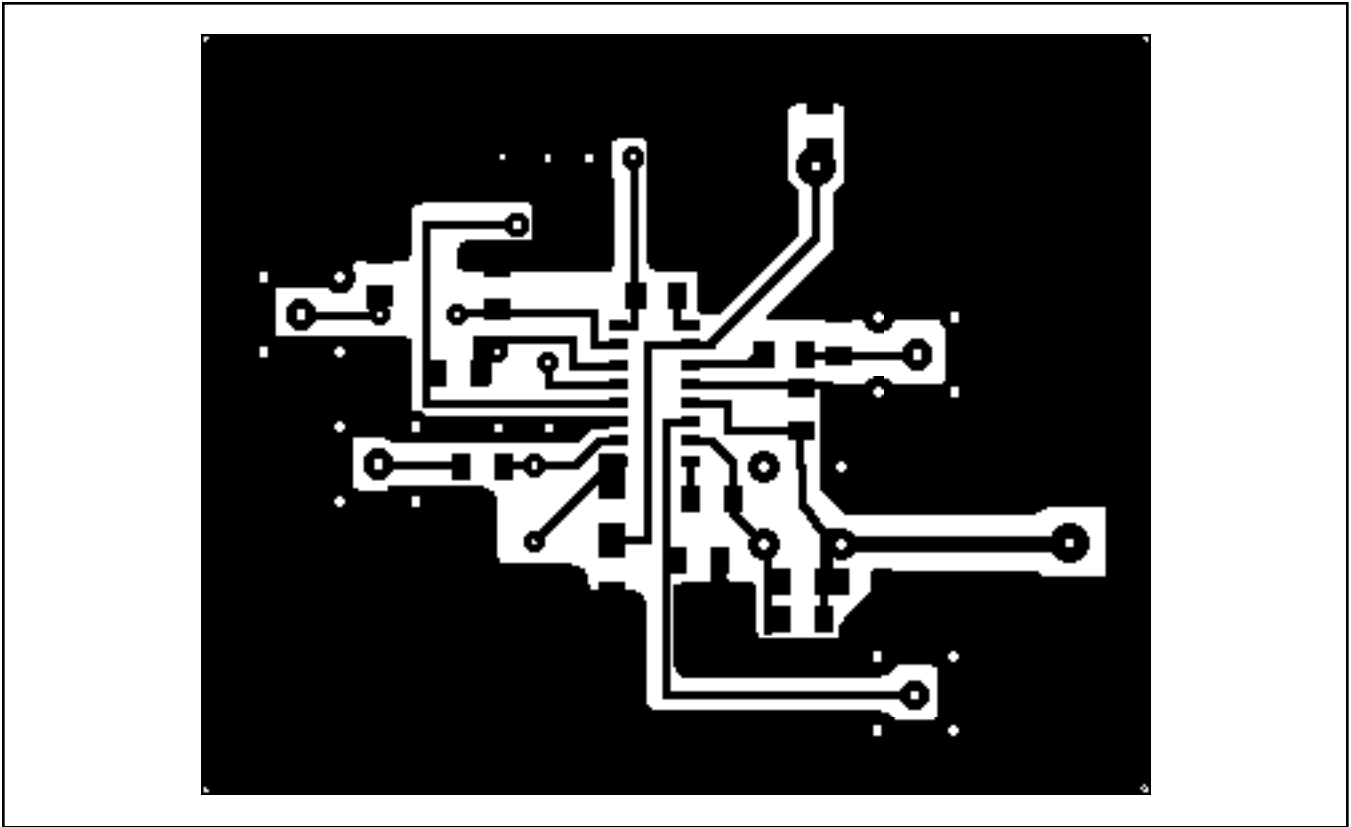

Fig. 18 Track side of demonstration board. Scale = 2:1.

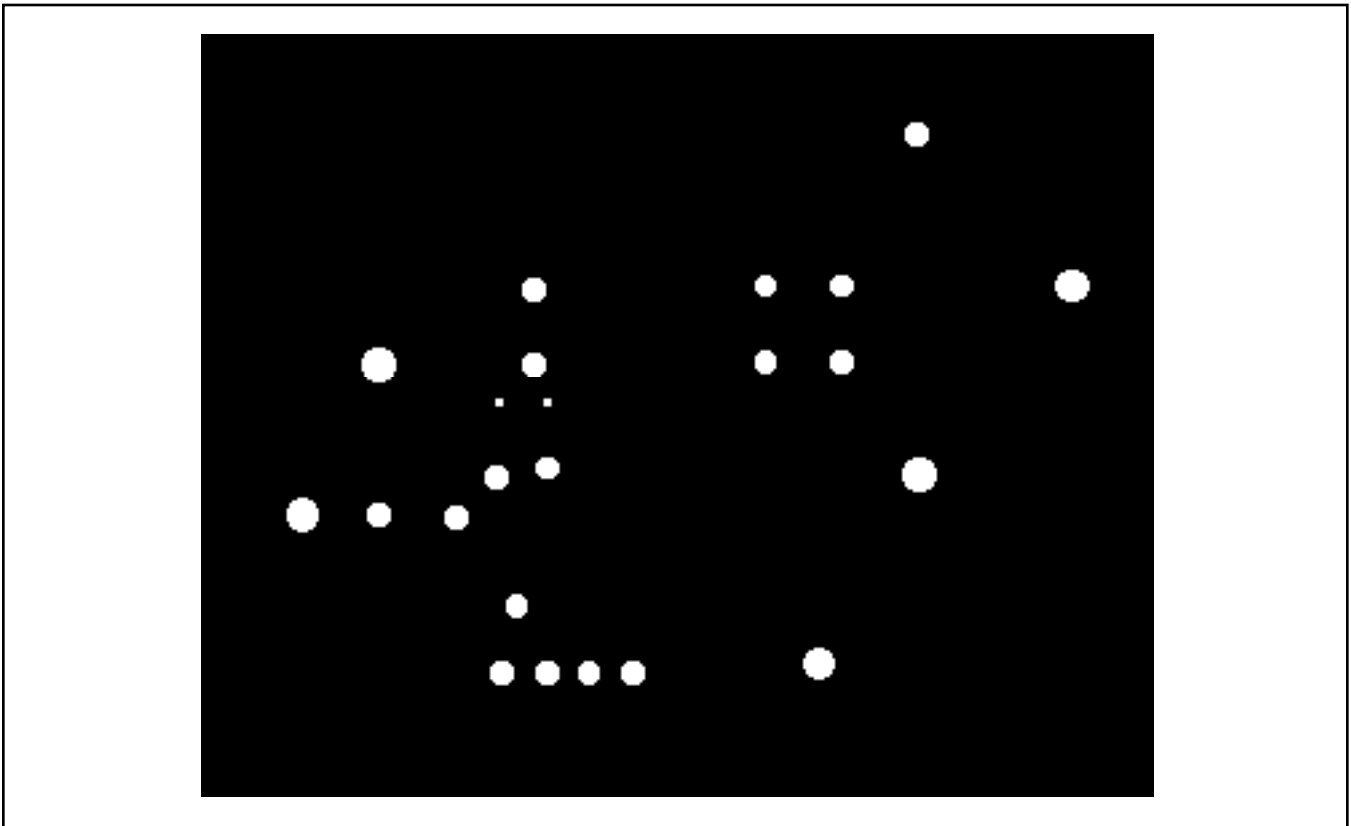

Fig. 19 Ground plane side of demonstration board. Scale = 2:1.

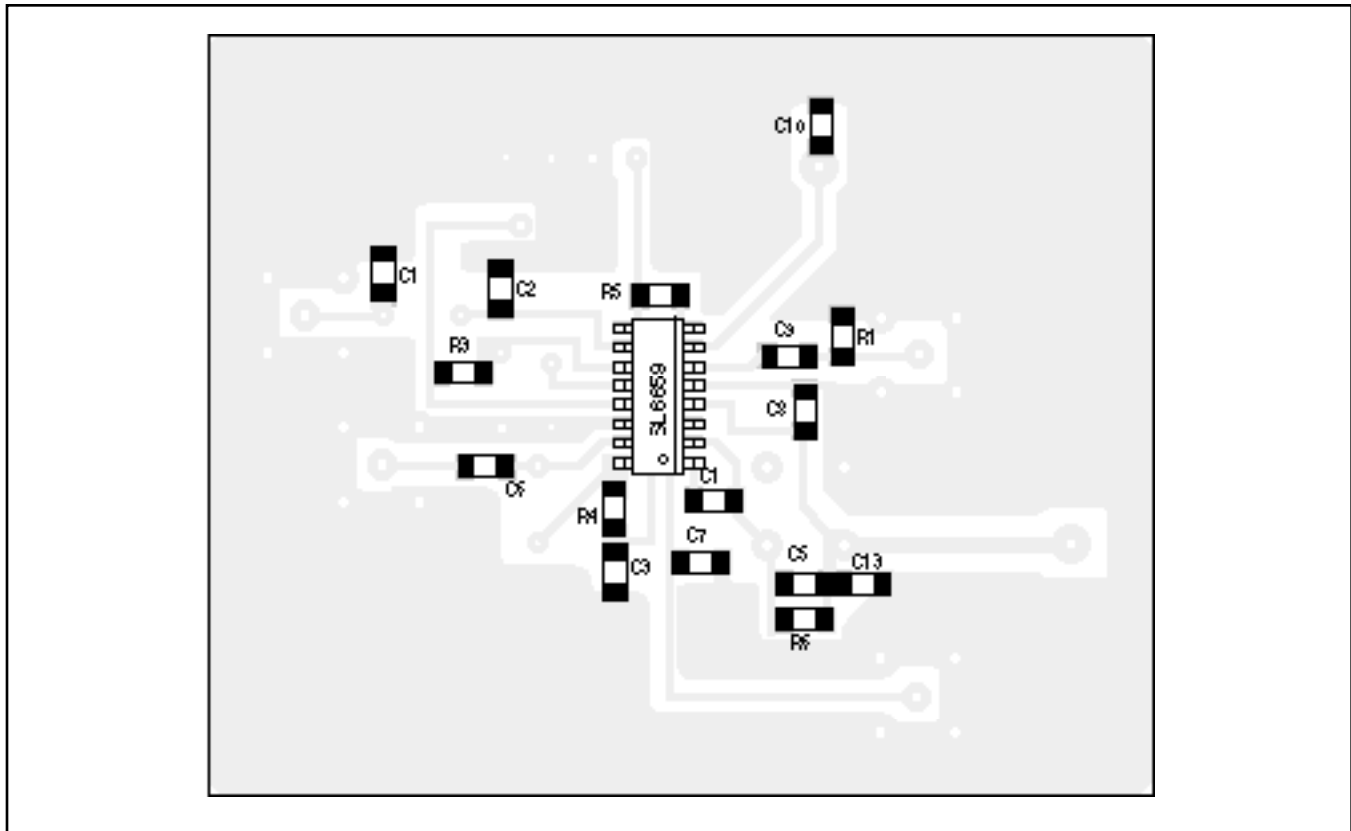

Fig. 20 Demonstration board surface mount component overlay (track side). Scale = 2:1.

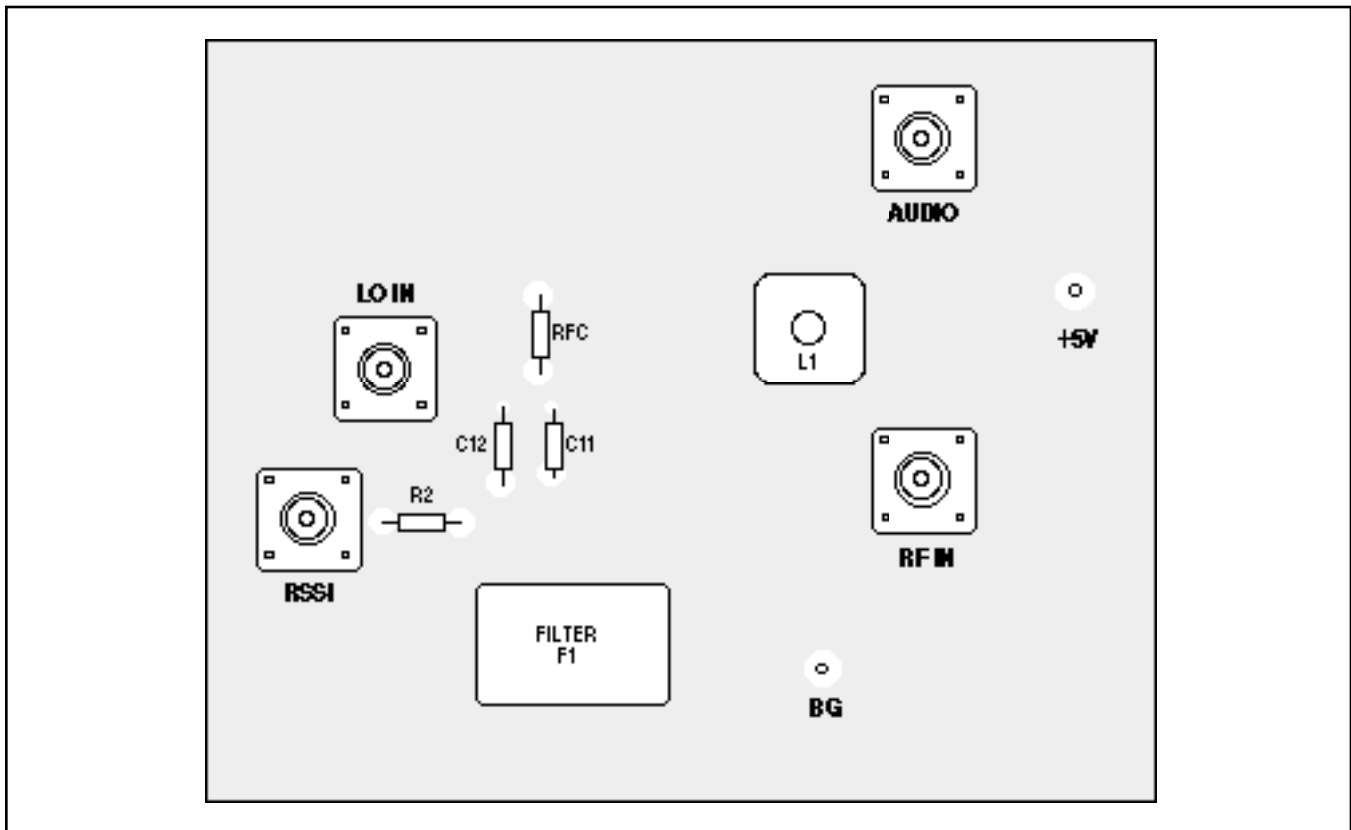

Fig. 21 Demonstration board connectors and through-board component overlay (ground plane side). Scale = 2:1.

COMPONENT LIST

Resistors		Capacitors		Inductors		Filter	
R1	51	C1	100nF	C8	470nF	L1* 330 μ H (adjustable), CAMBION Type 553-7107-43 RFC* 4.7 μ H	F1* MURATA Type CFW 445 E
R2*	1k	C2	10nF	C9	10nF		
R3	1.5k	C3	10nF	C10	100nF		
R4	10k	C4	10pF	C11	220nF*		
R5	1.5k	C5	330pF	C12	220nF*		
R6	33k	C6	1nF	C13	220nF		
		C7	270pF				

Components marked thus: * are through-board mounted from the ground plane side; all other components are surface mounted on the track side. See Figs. 20 and 21.

NOTES

NOTES

PACKAGE DETAILS

Dimensions are shown thus: mm (in).

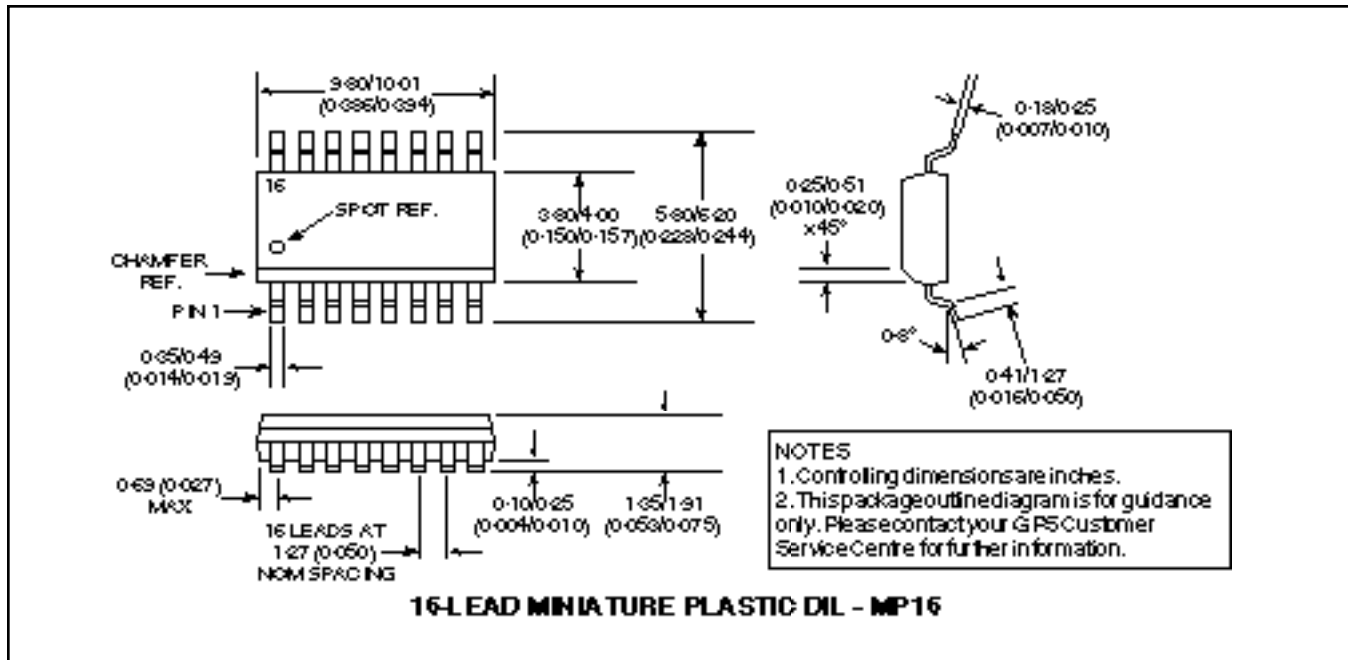

HEADQUARTERS OPERATIONS
GEC PLESSEY SEMICONDUCTORS
 Cheney Manor, Swindon,
 Wiltshire SN2 2QW, United Kingdom.
 Tel: (0793) 518000
 Fax: (0793) 518411

GEC PLESSEY SEMICONDUCTORS
 P.O. Box 660017
 1500 Green Hills Road,
 Scotts Valley, CA95067-0017
 United States of America.
 Tel (408) 438 2900
 Fax: (408) 438 5576

CUSTOMER SERVICE CENTRES

- **FRANCE & BENELUX** Les Ulis Cedex Tel: (1) 64 46 23 45 Fax : (1) 64 46 06 07
- **GERMANY** Munich Tel: (089) 3609 06-0 Fax : (089) 3609 06-55
- **ITALY** Milan Tel: (02) 66040867 Fax: (02) 66040993
- **JAPAN** Tokyo Tel: (3) 5276-5501 Fax: (3) 5276-5510
- **NORTH AMERICA** Scotts Valley, USA Tel: (408) 438 2900 Fax: (408) 438 7023.
- **SOUTH EAST ASIA** Singapore Tel: (65) 3827708 Fax: (65) 3828872
- **SWEDEN** Stockholm Tel: 46 8 702 97 70 Fax: 46 8 640 47 36
- **TAIWAN, ROC** Taipei Tel: 886 2 5461260 Fax: 886 2 7190260
- **UK, EIRE, DENMARK, FINLAND & NORWAY**
 Swindon Tel: (0793) 518510 Fax : (0793) 518582

These are supported by Agents and Distributors in major countries world-wide.
 © GEC Plessey Semiconductors 1994 Publication No. DS2471 Issue No. 3.1 June 1994
 TECHNICAL DOCUMENTATION – NOT FOR RESALE. PRINTED IN UNITED KINGDOM

This publication is issued to provide information only which (unless agreed by the Company in writing) may not be used, applied or reproduced for any purpose nor form part of any order or contract nor to be regarded as a representation relating to the products or services concerned. No warranty or guarantee express or implied is made regarding the capability, performance or suitability of any product or service. The Company reserves the right to alter without prior knowledge the specification, design or price of any product or service. Information concerning possible methods of use is provided as a guide only and does not constitute any guarantee that such methods of use will be satisfactory in a specific piece of equipment. It is the user's responsibility to fully determine the performance and suitability of any equipment using such information and to ensure that any publication or data used is up to date and has not been superseded. These products are not suitable for use in any medical products whose failure to perform may result in significant injury or death to the user. All products and materials are sold and services provided subject to the Company's conditions of sale, which are available on request.



**For more information about all Zarlink products
visit our Web Site at
www.zarlink.com**

Information relating to products and services furnished herein by Zarlink Semiconductor Inc. or its subsidiaries (collectively "Zarlink") is believed to be reliable. However, Zarlink assumes no liability for errors that may appear in this publication, or for liability otherwise arising from the application or use of any such information, product or service or for any infringement of patents or other intellectual property rights owned by third parties which may result from such application or use. Neither the supply of such information or purchase of product or service conveys any license, either express or implied, under patents or other intellectual property rights owned by Zarlink or licensed from third parties by Zarlink, whatsoever. Purchasers of products are also hereby notified that the use of product in certain ways or in combination with Zarlink, or non-Zarlink furnished goods or services may infringe patents or other intellectual property rights owned by Zarlink.

This publication is issued to provide information only and (unless agreed by Zarlink in writing) may not be used, applied or reproduced for any purpose nor form part of any order or contract nor to be regarded as a representation relating to the products or services concerned. The products, their specifications, services and other information appearing in this publication are subject to change by Zarlink without notice. No warranty or guarantee express or implied is made regarding the capability, performance or suitability of any product or service. Information concerning possible methods of use is provided as a guide only and does not constitute any guarantee that such methods of use will be satisfactory in a specific piece of equipment. It is the user's responsibility to fully determine the performance and suitability of any equipment using such information and to ensure that any publication or data used is up to date and has not been superseded. Manufacturing does not necessarily include testing of all functions or parameters. These products are not suitable for use in any medical products whose failure to perform may result in significant injury or death to the user. All products and materials are sold and services provided subject to Zarlink's conditions of sale which are available on request.

Purchase of Zarlink's I²C components conveys a licence under the Philips I²C Patent rights to use these components in and I²C System, provided that the system conforms to the I²C Standard Specification as defined by Philips.

Zarlink, ZL and the Zarlink Semiconductor logo are trademarks of Zarlink Semiconductor Inc.

Copyright Zarlink Semiconductor Inc. All Rights Reserved.

TECHNICAL DOCUMENTATION - NOT FOR RESALE
