

5A 600V 4 circuits Thyristor array

SLA0201

Features

- 5A 4 Thyristors combined one package
- Repetitive peak off-state voltage: $V_{DRM}=600V$
- Average on-state current: $I_{T(AV)}=5A$
- Gate trigger current: $I_{GT}=10mA$ max

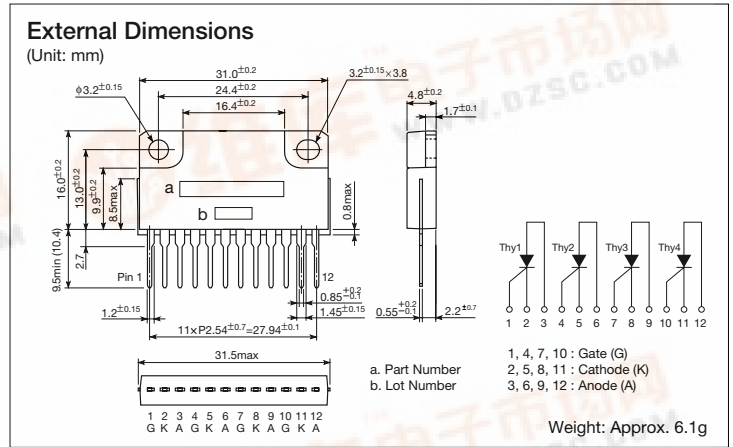

Absolute Maximum Ratings

Parameter	Symbol	Ratings	Unit	Conditions
Repetitive peak off-state voltage	V_{DRM}	600	V	$T_j = -40$ to $+125^\circ C$, $R_{GK} = 1k\Omega$
Repetitive peak reverse voltage	V_{RRM}	600	V	
Non-repetitive peak off-state voltage	V_{DSM}	650	V	
Non-repetitive peak reverse voltage	V_{RSM}	650	V	
Average on-state current	$I_{T(AV)}$	5.0	A	50Hz Half-cycle sinewave, Conduction angle 180° , Continuous current
RMS on-state current	$I_{T(RMS)}$	7.8	A	
Surge on-state current	I_{TSM}	80	A	50Hz Half-cycle sinewave, Single shot, Non-repetitive, $T_j = 125^\circ C$
Peak forward gate current	I_{FGM}	2.0	A	$f \geq 50Hz$, duty $\leq 10\%$
Peak forward gate voltage	V_{FGM}	10	V	
Peak reverse gate voltage	V_{RGM}	5.0	V	$f \geq 50Hz$
Peak gate power loss	P_{GM}	5.0	W	$f \geq 50Hz$, duty $\leq 10\%$
Average gate power loss	$P_{G(AV)}$	0.5	W	
Junction temperature	T_j	-40 to $+125$	$^\circ C$	
Storage temperature	T_{stg}	-40 to $+125$	$^\circ C$	

Electrical Characteristics

Parameter	Symbol	Ratings			Unit	Conditions
		min	typ	max		
Off-state current	I_{DRM}			2.0	mA	$T_j = 125^\circ C$, $V_D = 600V$, $R_{GK} = 1k\Omega$
				100	μA	$T_j = 25^\circ C$, $V_D = 600V$, $R_{GK} = 1k\Omega$
Reverse current	I_{RRM}			2.0	mA	$T_j = 125^\circ C$, $V_D = 600V$, $R_{GK} = 1k\Omega$
				100	μA	$T_j = 25^\circ C$, $V_D = 600V$, $R_{GK} = 1k\Omega$
On-state voltage	V_{TM}			1.4	V	$T_C = 25^\circ C$, $I_{TM} = 10A$
Gate trigger voltage	V_{GT}		0.7	1.5	V	$V_D = 6V$, $R_L = 10\Omega$, $T_C = 25^\circ C$
Gate trigger current	I_{GT}		5.0	10	mA	
Gate non-trigger voltage	V_{GD}	0.1			V	$V_D = 1/2 \times V_{DRM}$, $T_j = 125^\circ C$, $R_{GK} = 1k\Omega$
Holding current	I_H		4.0		mA	$R_{GK} = 1k\Omega$, $T_j = 25^\circ C$
Critical rate-of-rise of off-state voltage	dv/dt		50		V/ μS	$V_D = 1/2 \times V_{DRM}$, $T_j = 125^\circ C$, $R_{GK} = 1k\Omega$, $C_{GK} = 0.033\mu F$
Total power dissipation	P_T			4	W	Without Heatsink, $T_j = 25^\circ C$, All elements operation
				32		With infinite Heatsink, $T_j = 25^\circ C$, All elements operation

