

SLA3001M/3002M/3004M

3-Output Dropper/Switching Type

Features

- 3 regulator ICs combined in 1 package
- Insulated single inline package
- Can be used with dropper type and switching type
- 3 independent circuits for input and output respectively. Internal dissipation can be reduced since different input voltages can be applied.
- Dropper type regulator IC is low-dropout voltage type with input/output voltage difference of 1V. Output ON/OFF control, variable output voltage (rise only) function
- Switching type: built-in separate excitation (60kHz), high efficiency of 80% or over
- Each regulator has overcurrent protection and thermal protection circuit.

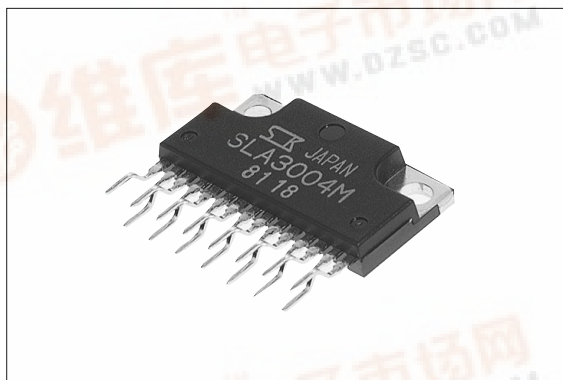

Applications

- For stabilization of the secondary stage of switching power supplies
- Electronic equipment

Lineup

Part Number	SLA3001M			SLA3002M			SLA3004M		
	Type	Vo(V)	Io(A)	Type	Vo (V)	Io(A)	Type	Vo (V)	Io (A)
Regulator 1	Dropper	12	1.5	Switching	5	0.5	Switching	5	0.5
Regulator 2	Dropper	5	1.5	Dropper	15.7	1.0	Switching	9	0.4
Regulator 3	Dropper	9	1.5	Switching	9	0.4	Switching	9	0.4

Absolute Maximum Ratings

Parameter	Symbol	Ratings									Unit
		SLA3001M			SLA3002M			SLA3004M			
		Reg1	Reg2	Reg3	Reg1	Reg2	Reg3	Reg1	Reg2	Reg3	
DC Input Voltage	V _{IN}	35			35			35			V
Voltage of Output Control Terminal	V _c	V _{IN}			—	V _{IN}	—	—			V
SW Terminal Applied Reverse Voltage	V _{sw}	—			-1	—	-1	-1			V
Power Dissipation	P _D	40(T _c =25°C)			37.5(T _c =25°C)			37.5(T _c =25°C)			W
Junction Temperature	T _j	+125			+150			+150			°C
Storage Temperature	T _{stg}	-40 to +125			-40 to +150			-40 to +150			°C
Ambient Operating Temperature	T _{op}	-30 to +85			-30 to +85			-30 to +85			°C
Thermal Resistance(junction-to-case)	R _{th(j-c)}	7			10			10			°C/W

■Electrical Characteristics

(Ta=25°C unless otherwise specified)

	Parameter	Symbol	Ratings									Unit
			SLA3001M			SLA3002M			SLA3004M			
			min.	typ.	max.	min.	typ.	max.	min.	typ.	max.	
Regulator 1	Recommended DC Input Voltage	V _{IN1}	13		25	7		33	7		33	V
	Output Voltage	V _{O1}	11.52	12.00	12.48	4.75	5.00	5.25	4.75	5.00	5.25	V
		Conditions	V _{IN} =15V, I _O =1.0A			V _{IN} =20V, I _O =0.3A			V _{IN} =20V, I _O =0.3A			
	Dropout Voltage	V _{DIF1}			1.0							V
		Conditions	I _O =1.5A									
	Efficiency	η ₁					80			80		%
		Conditions				V _{IN} =20V, I _O =0.3A			V _{IN} =20V, I _O =0.3A			
	Line Regulation	ΔV _{LINE1}		24	64		80	100		80	110	mV
		Conditions	V _{IN} =13 to 25V, I _O =1.0A			V _{IN} =10 to 30V, I _O =0.3A			V _{IN} =10 to 30V, I _O =0.3A			
	Load Regulation	ΔV _{LOAD1}		93	240		30	40		30	40	mV
Conditions		V _{IN} =15V, I _O =0 to 1.5A			V _{IN} =20V, I _O =0.1 to 0.4A			V _{IN} =20V, I _O =0.1 to 0.4A				
Switching Frequency	f ₁					60			60		kHz	
	Conditions				V _{IN} =20V, I _O =0.3A			V _{IN} =20V, I _O =0.3A				
Overcurrent Protection Starting Current* ¹	I _{S1, 1}	1.6			0.55			0.55			A	
	Conditions	V _{IN} =15V			V _{IN} =10V			V _{IN} =10V				
V _C Terminal ²	Control Voltage (Output ON)	V _{CIH, 1}	2.0								V	
	Control Voltage (Output OFF)	V _{CIL, 1}			0.8						V	
Regulator 2	Recommended DC Input Voltage	V _{IN2}	6		15	17		30	12		33	V
	Output Voltage	V _{O2}	4.85	5.00	5.15	14.92	15.70	16.48	8.55	9.00	9.45	V
		Conditions	V _{IN} =8V, I _O =1.0A			V _{IN} =19V, I _O =0.5A			V _{IN} =21V, I _O =0.3A			
	Dropout Voltage	V _{DIF2}			1.0			1.0				V
		Conditions	I _O =1.5A			I _O =1.0A						
	Efficiency	η ₂								85		%
		Conditions							V _{IN} =21V, I _O =0.3A			
	Line Regulation	ΔV _{LINE2}		10	30		30	90		90	110	mV
		Conditions	V _{IN} =6 to 15V, I _O =1.0A			V _{IN} =17 to 25V, I _O =0.5A			V _{IN} =14 to 30V, I _O =0.3A			
	Load Regulation	ΔV _{LOAD2}		40	100		120	300		50	80	mV
Conditions		V _{IN} =8V, I _O =0 to 1.5A			V _{IN} =19V, I _O =0 to 0.1A			V _{IN} =21V, I _O =0.1 to 0.4A				
Switching Frequency	f ₂								60		kHz	
	Conditions							V _{IN} =21V, I _O =0.3A				
Overcurrent Protection Starting Current* ¹	I _{S1, 2}	1.6			1.2			0.45			A	
	Conditions	V _{IN} =8V			V _{IN} =19V			V _{IN} =14V				
V _C Terminal ²	Control Voltage (Output ON)	V _{CIH, 2}	2.0			2.0					V	
	Control Voltage (Output OFF)	V _{CIL, 2}			0.8			0.8			V	
Regulator 3	Recommended DC Input Voltage	V _{IN3}	10		20	12		33	12		33	V
	Output Voltage	V _{O3}	8.64	9.00	9.36	8.55	9.00	9.45	8.64	9.00	9.36	V
		Conditions	V _{IN} =12V, I _O =1.0A			V _{IN} =21V, I _O =0.3A			V _{IN} =21V, I _O =0.3A			
	Dropout Voltage	V _{DIF3}			1.0							V
		Conditions	I _O =1.5A									
	Efficiency	η ₃					85			85		%
		Conditions				V _{IN} =21V, I _O =0.3A			V _{IN} =21V, I _O =0.3A			
	Line Regulation	ΔV _{LINE3}		18	48		90	110		90	110	mV
		Conditions	V _{IN} =10 to 20V, I _O =1.0A			V _{IN} =14 to 30V, I _O =0.3A			V _{IN} =14 to 30V, I _O =0.3A			
	Load Regulation	ΔV _{LOAD3}		70	180		50	80		50	80	mV
Conditions		V _{IN} =15V, I _O =0 to 1.5A			V _{IN} =21V, I _O =0.1 to 0.4A			V _{IN} =21V, I _O =0.1 to 0.4A				
Switching Frequency	f ₃					60			60		kHz	
	Conditions				V _{IN} =21V, I _O =0.3A			V _{IN} =21V, I _O =0.3A				
Overcurrent Protection Starting Current* ¹	I _{S1, 3}	1.6			0.45			0.45			A	
	Conditions	V _{IN} =12V			V _{IN} =14V			V _{IN} =14V				
V _C Terminal ²	Control Voltage (Output ON)	V _{CIH, 3}	2.0								V	
	Control Voltage (Output OFF)	V _{CIL, 3}			0.8						V	

*1: I_{S1} of Dropper Type is specified at -5(%) drop point of output voltage V_O. I_{S1} of Switching Type is specified at -10(%) drop point of output voltage V_O.

■Outline Drawing

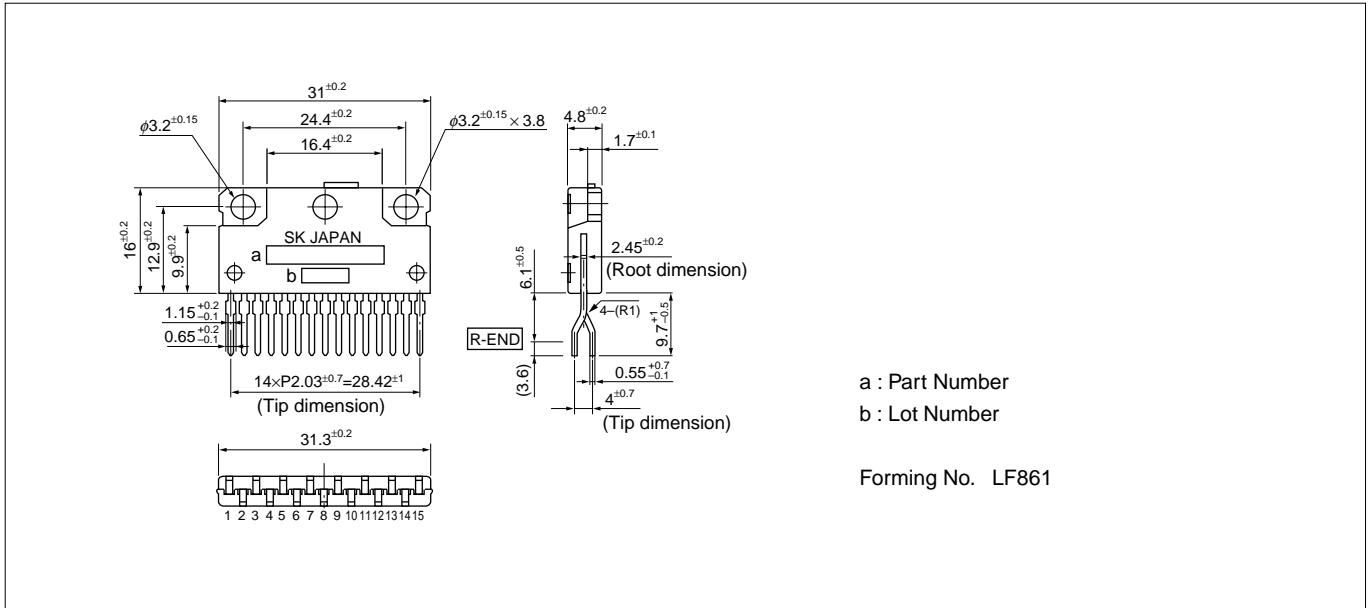

■Block Diagram

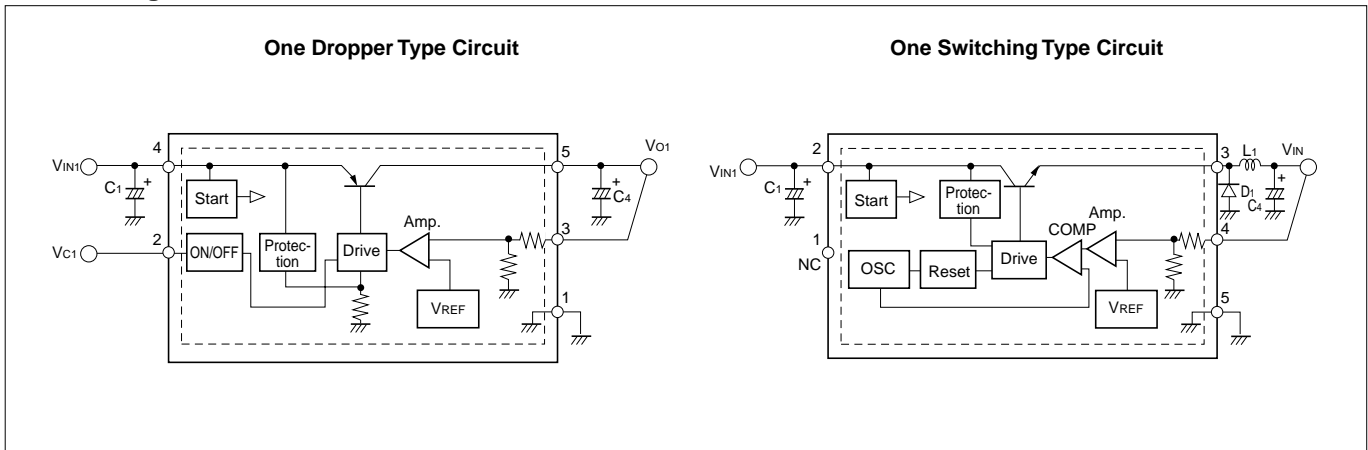

■Standard External Circuit

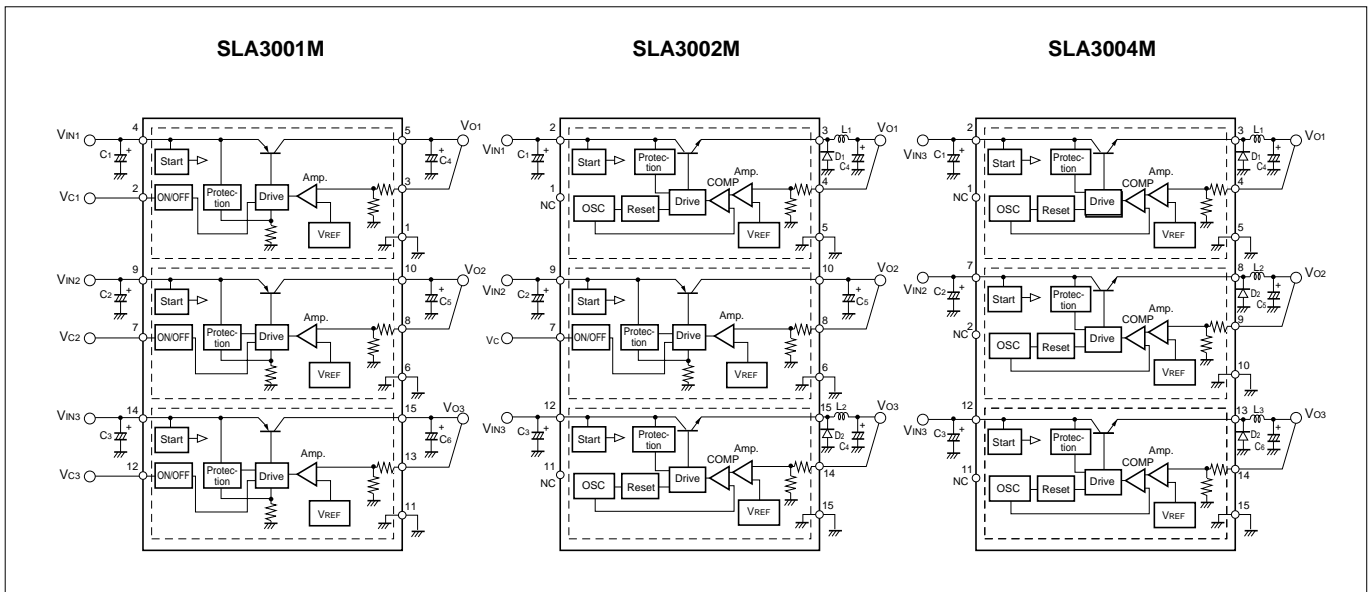

■Selecting External components for dropper type regulator

Input capacitor (Approx. 47 μ F)

Output capacitor (Approx. 47 to 100 μ F)

- Low ESR capacitors are recommended for input and output when using them in low temperature conditions (0°C or less)

■Selecting External components for switching type regulator

Input capacitor (Approx. 100 μ F)

Output smoothing capacitor (Approx. 330 μ F)

- Input capacitor and output capacitor must satisfy allowable ripple current.
- Low ESR capacitors are recommended for reducing output ripple voltage.
- Low ESR capacitors are recommended for input and output when using them in low temperature conditions (0°C or less)

Choke coil (200 μ H when V_o is 3.3V or 5V, 300 μ H when V_o is not 3.3V or 5V)

- When its winding resistance is high, its efficiency may decrease and the rated value may not be achieved.
- Pay attention to heat from the choke coil due to magnetic saturation caused by overload, short circuit of load, etc. because the overcurrent protection starting current is approx. 1A.

Flywheel diode (Sanken AK04 recommended)

- Use a Schottky barrier diode for D₁, D₂ and D₃ and make sure that the reverse voltage applied to SW output terminal does not exceed the value (-1V) given in the maximum ratings.
- If you use a fast recovery diode or any other diode, application of a reverse voltage generated from the recovery or ON voltage of the diode may damage the IC.

■Typical Characteristics

($T_a=25^{\circ}\text{C}$)

SLA3001M (Regulator 2, $V_o=5\text{V}$)

Rise Characteristics

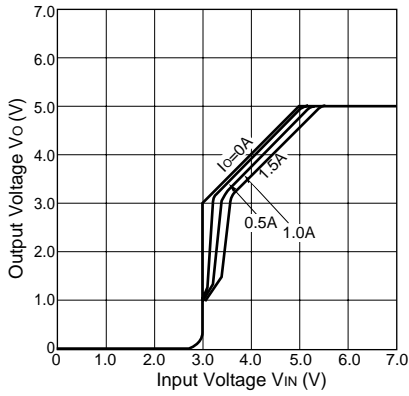

Line Regulation

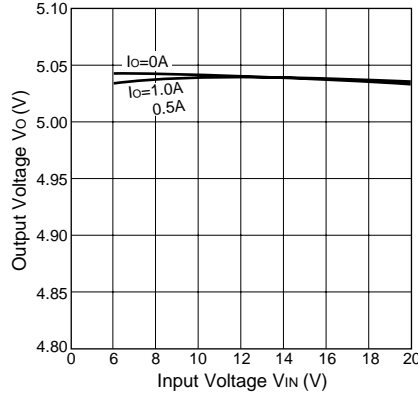

Load Regulation

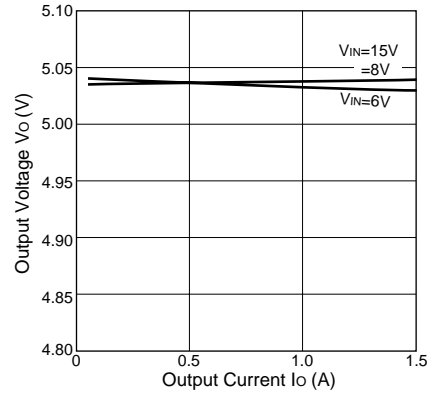

Overcurrent Protection Characteristics

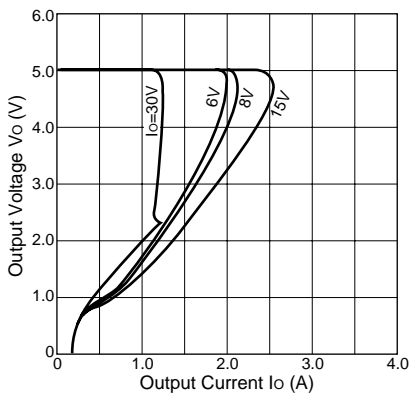

ON/OFF Control Characteristics

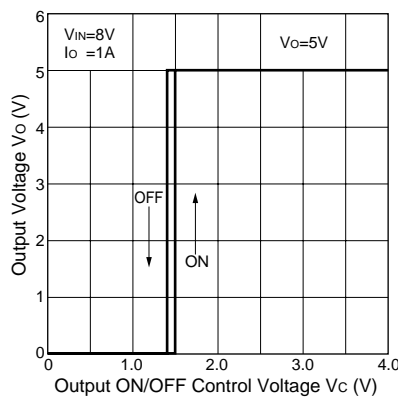

Thermal Protection Characteristics

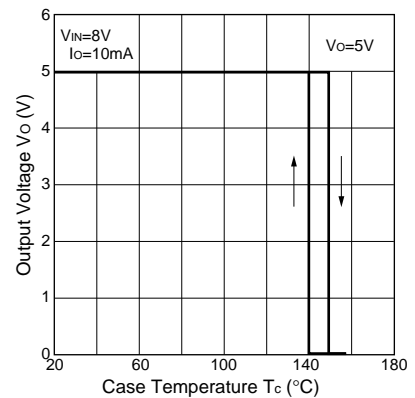

Note on Thermal Protection:
The thermal protection circuit is intended for protection against heat during instantaneous short-circuiting. Its operation is not guaranteed for short-circuiting over extended periods of time.

SLA3002M/SLA3004M(Regulator 1, $V_o=5\text{V}$)

Rise Characteristics

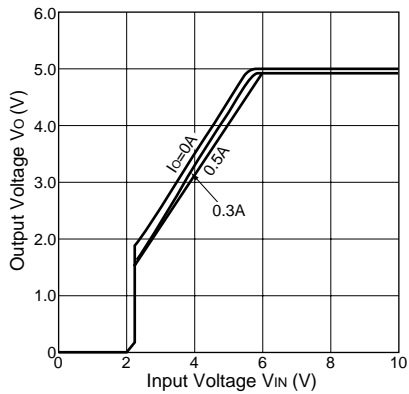

Load Regulation

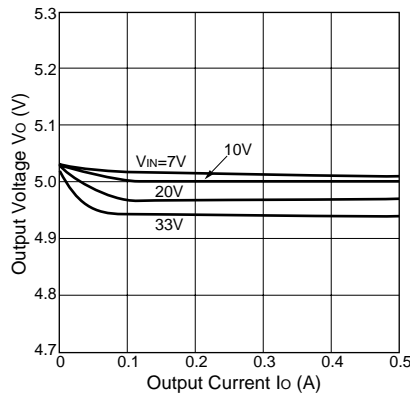

Efficiency Characteristics

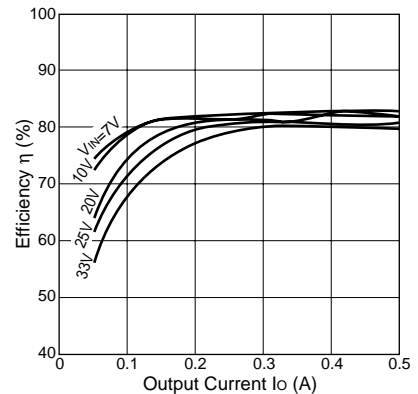

Overcurrent Protection Characteristics

