

SM 513, SM 516, SM 518, SM 2000

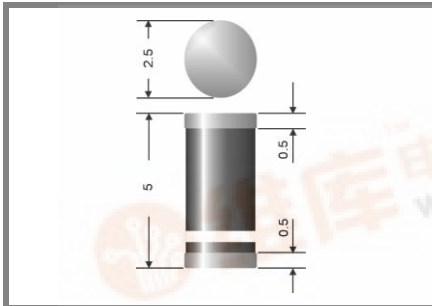

Surface mount diode

Standard silicon rectifier diodes

SM 513, SM 516, SM 518, SM 2000

Forward Current: 1 A

Reverse Voltage: 1300 to 2000 V

Features

- Max. solder temperature: 260°C
- Plastic material has UL classification 94V-0

Mechanical Data

- Plastic case Melf / DO-213AB
- Weight approx. 0,12 g
- Terminals: plated terminals solderable per MIL-STD-750
- Mounting position: any
- Standard packaging: 5000 pieces per reel

- 1) Max. temperature of the terminals $T_T = 75\text{ }^\circ\text{C}$
- 2) $I_F = 1\text{ A}$, $T_j = 25\text{ }^\circ\text{C}$
- 3) $T_A = 25\text{ }^\circ\text{C}$
- 4) Mounted on P.C. board with 25 mm² copper pads at each terminal

Type	Polarity color band	Repetitive peak reverse voltage V_{RRM} V	Surge peak reverse voltage V_{RSM} V	Maximum forward voltage $T_j = 25\text{ }^\circ\text{C}$ $I_F = 1\text{ A}$ $V_F^{2)}$ V	Maximum reverse recovery time $I_F = -\text{A}$ $I_R = -\text{A}$ $I_{RR} = -\text{A}$ t_{rr} ns
SM 513	-	1300	1300	1,1	-
SM 516	-	1600	1600	1,1	-
SM 518	-	1800	1800	1,1	-
SM 2000	-	2000	2000	1,1	-

Absolute Maximum Ratings $T_c = 25\text{ }^\circ\text{C}$, unless otherwise specified			
Symbol	Conditions	Values	Units
I_{FAV}	Max. averaged fwd. current, R-load, $T_T = 75\text{ }^\circ\text{C}$	1	A
I_{FRM}	Repetitive peak forward current $f > 15\text{ Hz}^1)$	10	A
I_{FSM}	Peak fwd. surge current 50 Hz half sinus-wave ³⁾	40	A
I^2t	Rating for fusing, $t < 10\text{ ms}^3)$	8	A ² s
R_{thA}	Max. thermal resistance junction to ambient ⁴⁾	45	K/W
R_{thT}	Max. thermal resistance junction to terminals	10	K/W
T_j	Operating junction temperature	-50...+175	°C
T_s	Storage temperature	-50...+175	°C

Characteristics $T_c = 25\text{ }^\circ\text{C}$, unless otherwise specified			
Symbol	Conditions	Values	Units
I_R	Maximum leakage current, $T_j = 25\text{ }^\circ\text{C}$; $V_R = V_{RRM}$ $T_j = 100\text{ }^\circ\text{C}$; $V_R = V_{RRM}$	<5 <50	μA μA
C_J	Typical junction capacitance (at MHz and applied reverse voltage of V)	-	pF
Q_{rr}	Reverse recovery charge ($U_R = V$; $I_F = A$; $dI_F/dt = A/ms$)	-	μC
E_{RSM}	Non repetitive peak reverse avalanche energy ($I_R = \text{mA}$; $T_j = \text{ }^\circ\text{C}$; inductive load switched off)	-	mJ

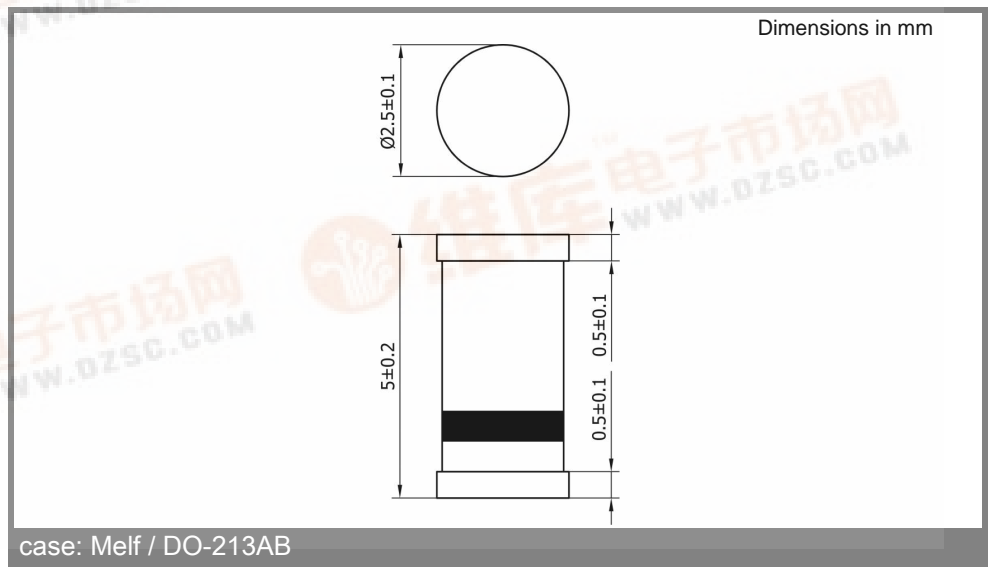

SM 513, SM 516, SM 518, SM 2000

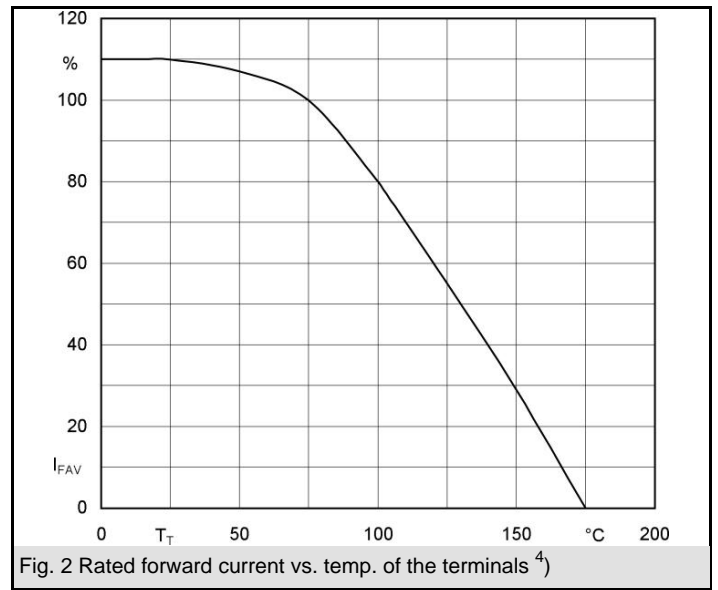
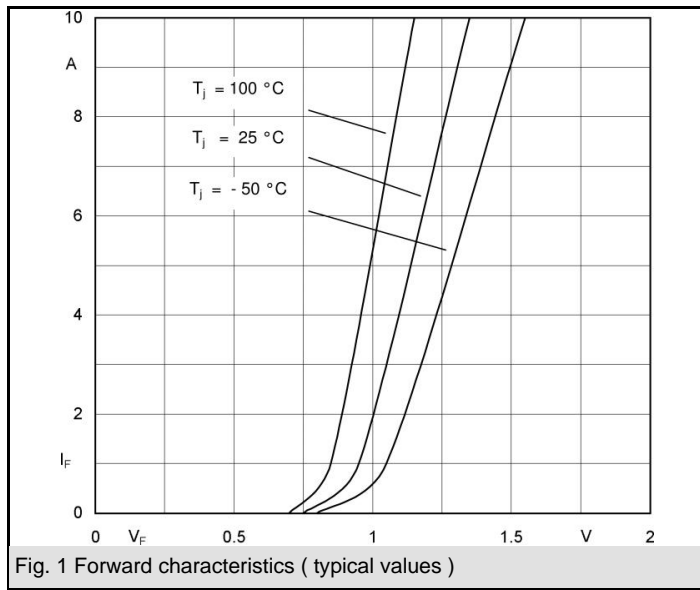

Copyright © Each Manufacturing Company.

All Datasheets cannot be modified without permission.

This datasheet has been download from :

www.AllDataSheet.com

100% Free DataSheet Search Site.

Free Download.

No Register.

Fast Search System.

www.AllDataSheet.com