



SM2337

**1200 VOLT
ULTRA FAST RECOVERY RECTIFIER
PRODUCT PREVIEW**

DESCRIPTION

High Voltage, Low Leakage, Ultra Fast Rectifier

IMPORTANT: For the most current data, consult *MICROSEMI*'s website: <http://www.microsemi.com>

KEY FEATURES

- Available in axial leaded package
- Ultra Fast Recovery Time
- High Voltage
- Metallurgical bonding
- Voidless hermetically sealed glass package
- TX, TXV and space level screening available Per Internal Process Specification and SM2337TX, SM2337TXV per PS7.00 SP2337US per PS15.85

APPLICATIONS/BENEFITS

- TWT design
- Reverse Recovery less than 20 nano seconds.
- C_j less than 20pf
- Low VF
- 60 Amp Surge

MAXIMUM RATINGS @ 25°C (unless otherwise specified)

Description	Symbol	Min.	Max.	Unit
Minimum Breakdown Voltage	V_{BR}	1300		Volts
Working Peak Voltage	V_{RWM}		1200	Volts
Surge Current	I_{FSM}		60	Amps
Average Operating Current	I_o		2	Amps
Thermal Resistance	$R_{\theta jc}$		10	°C/W
Thermal Impedance	$Z_{\theta jx}$		1.2	°C/W
Storage and Junction Temperature Range	T_{stg}, T_j		-65 to +175	°C





SANTA ANA DIVISION

SM2337

**1200 VOLT
ULTRA FAST RECOVERY RECTIFIER
PRODUCT PREVIEW**

ELECTRICAL PARAMETERS @ 25°C (unless otherwise specified)

Description	Symbol	Conditions	Min	Max	Unit
Reverse (Leakage)	I_{R1}	$V_R = 1200 V_{dc}, T_A = 25^\circ C$		2.0	μA
Reverse (Leakage)	I_{R2}	$V_R = 1200 V, T_A = 100^\circ C$		75	μA
Forward Voltage	V_{F1}	$I_F = 1.0A, T_A = 25^\circ C, t_p = 10mSec.$		2.5	Volts
Forward Voltage	V_{F2}	$I_F = 2.0A, T_A = 25^\circ C, t_p = 10mSec.$		3.0	Volts
Breakdown Voltage	V_{BR}	$I_{BR} = 50\mu A, T_A = 25^\circ C$	1300		Volts
Forward Voltage	V_{F2}	$I_F = 1.0A, T_A = -55^\circ C$		3.0	Volts
Breakdown Voltage	V_{BR2}	$I_{BR} = 50\mu A, T_A = -55^\circ C$	1200		Volts
Reverse Recovery Time	t_{rr}	$I_F = 0.5A, I_R = 1.0A, I_{rm}(REC) = 0.25A$		20	nsec.
Thermal Impedance	$Z_{\theta jx}$	$I_M = 10mA, T_{md} = 100\mu Sec.(max), I_H = 5A(min), T_H = 10mSec.$		1.2	$^\circ C/W$
Thermal Resistance	$R_{\theta jeC}$	$I_M = 10mA, T_{md} = 100\mu Sec.(max), I_H = 2A(min), T_H = Thermal Equilibrium$		10	$^\circ C/W$
Forward Surge	IFSM	8.3mSec pulse, Half Sine Wave Superimposed on I_o , 1 Pulse per minute		60	Amps
Capacitance	C_j	$V_R = 10V, f = 1Mhz, V_{sig} = 50mV (p-p)$		20	pf



SANTA ANA DIVISION

SM2337

**1200 VOLT
ULTRA FAST RECOVERY RECTIFIER
PRODUCT PREVIEW**

E-MELF (SANTA ANA)

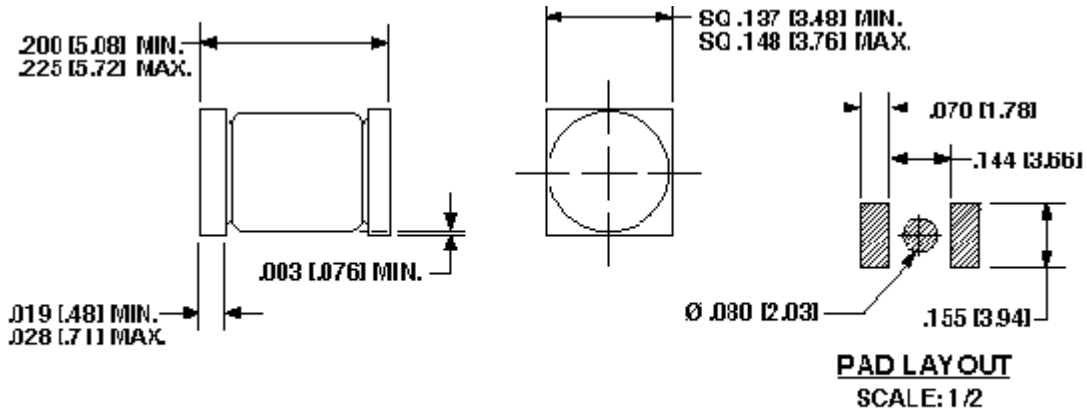

NOTE: DIMENSIONS IN [] = MILLIMETERS



Microsemi

SANTA ANA DIVISION

SM2337

**1200 VOLT
ULTRA FAST RECOVERY RECTIFIER
PRODUCT PREVIEW**

www.Microsemi.com

NOTES