

# SM3508

## 4-Bit Single-Chip Microcomputer (For Data Bank Use)

### DESCRIPTION

The SM3508 is a CMOS 4-bit single-chip micro-computer for databank incorporating data memory RAM, LCD driver (the output is adjustable in 16 steps for various contrast), key/switch input circuit, 8-bit parallel I/O port, 2 output ports and buzzer output circuit. The chip also has memory expansion controlling feature. One of two ports contains special output circuit for infrared (IR) communication. By connecting an external crystal, a 1 Hz timer is made possible for easier clock function.

### FEATURES

- ROM capacity :
 

Program ROM	12 k x 23 bits
Character ROM	6 x 8 x 256 bits
Constant ROM	1 k x 4 bits
  - RAM capacity :
 

Working RAM	256 x 4 bits
Display RAM	74 x 16 bits
Data RAM	3 k x 8 bits
  - Memory expansion (external) : 1M x 8 bits x 3
  - LCD display : 74-segment x 16-common
  - I/O ports :
 

Parallel I/O	8 bits
Input	2 bits
Output	2 bits
Buzzer output	1 bit (4 kHz)
Key input	6 bits
  - Standby release : 2 events (2 Hz signal, key input)
  - Built-in oscillator :
 

System clock (built-in CR oscillator)	1 MHz
(external ceramic resonator)	1 MHz
Timer (built-in CR oscillator)	32.8 kHz
(external crystal)	32.768 kHz
  - Instruction cycle time : 3  $\mu$ s
  - Operating temperature : -10 to + 60°C
  - Supply voltage : 2.5 to 5.5 V
  - Package : 128-pin QFP (QFP128-P-2828)
- [Test Sample only]



SYSTEM CONFIGURATION EXAMPLE

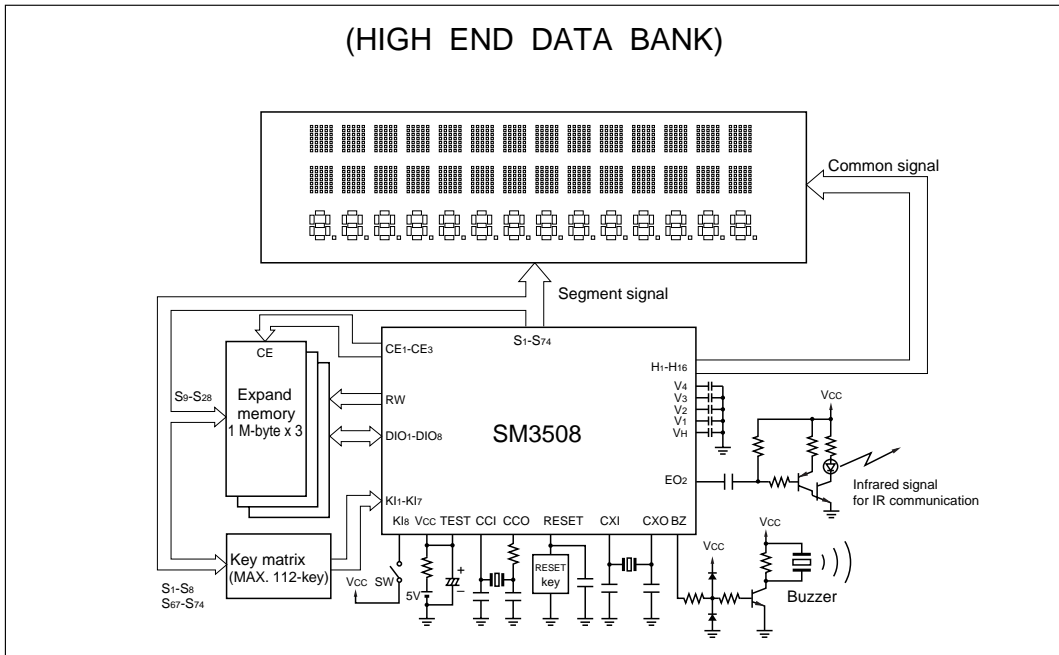

128 QFP (QFP128-P-2828)

