



三合微科技股份有限公司
SAMHOP Microelectronics Corp.

SM6B595

8-BIT LED DRIVER

GENERAL DESCRIPTION

The SM6B595 is specifically designed for USE in LED DISPLAY.

This device contains an 8-bit shift register, 8 bit D-type storage register and open-drain NMOS output drivers.

The serial output allows for cascading of the data from the shift register to additional devices.

FEATURES

- * Maximum output terminal voltage: 30V.
- * Maximum continuous drain current:100mA.
- * Typical $R_{DS(ON)}$: 5 Ω
- * Devices are cascadable
- * Low power consumption
- * Serial data transfer rate: 25 MHz.

PIN ASSIGNMENTS

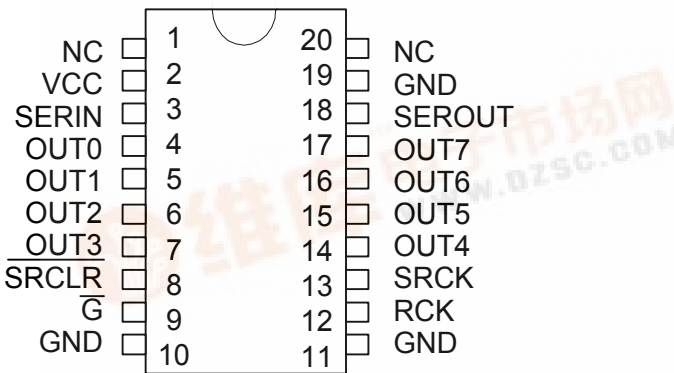

SM6B595P
20 PIN DIP

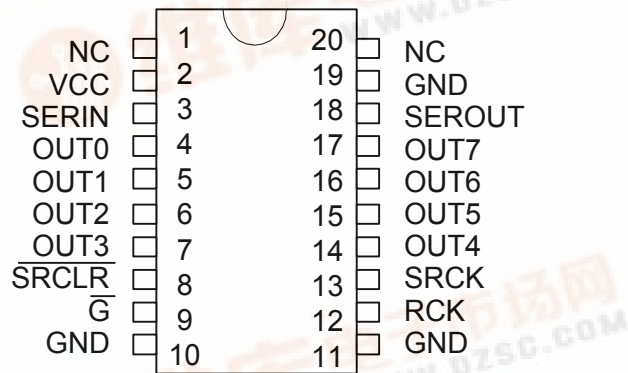

SM6B595F
20 PIN SOP





PIN DESCRIPTION

Pin NO.	Pin Name	Function Description
1	NC	No connection
2	Vcc	5V supply voltage terminal.
3	SER IN	Input terminal of a serial-data for shift-register.
4-7	OUT0~3	Output terminals.
8	SRCLR	Input terminal of clear signal for shift-register. When SRCLR is low, the input shift-register is cleared.
9	G	Input terminal of output enable. All outputs (OUT0~7) do off with "H" level of G-terminal, and do on with "L" level input.
10-11	GND	Ground terminal.
12	RCK	Input terminal of a clock for storage-register. Data transfer through storage-register on the rising edge of the storage-register clock.
13	SRCK	Input terminal of a clock for shift-register. Data transfer through shift-register on the rising edge of the shift-register clock.
14-17	OUT4~7	Output terminals.
18	SER OUT	Output terminal of serial-data for next SER IN terminal.
19	GND	Ground terminal.
20	NC	No connection.



BLOCK DIAGRAM

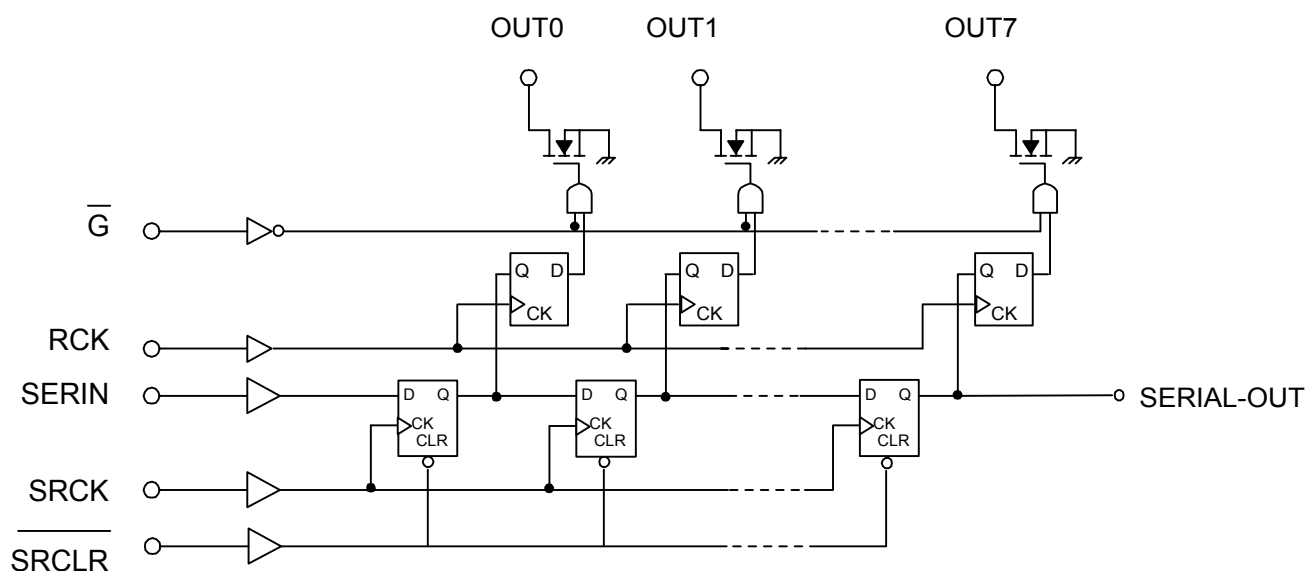

TIMING DIAGRAM

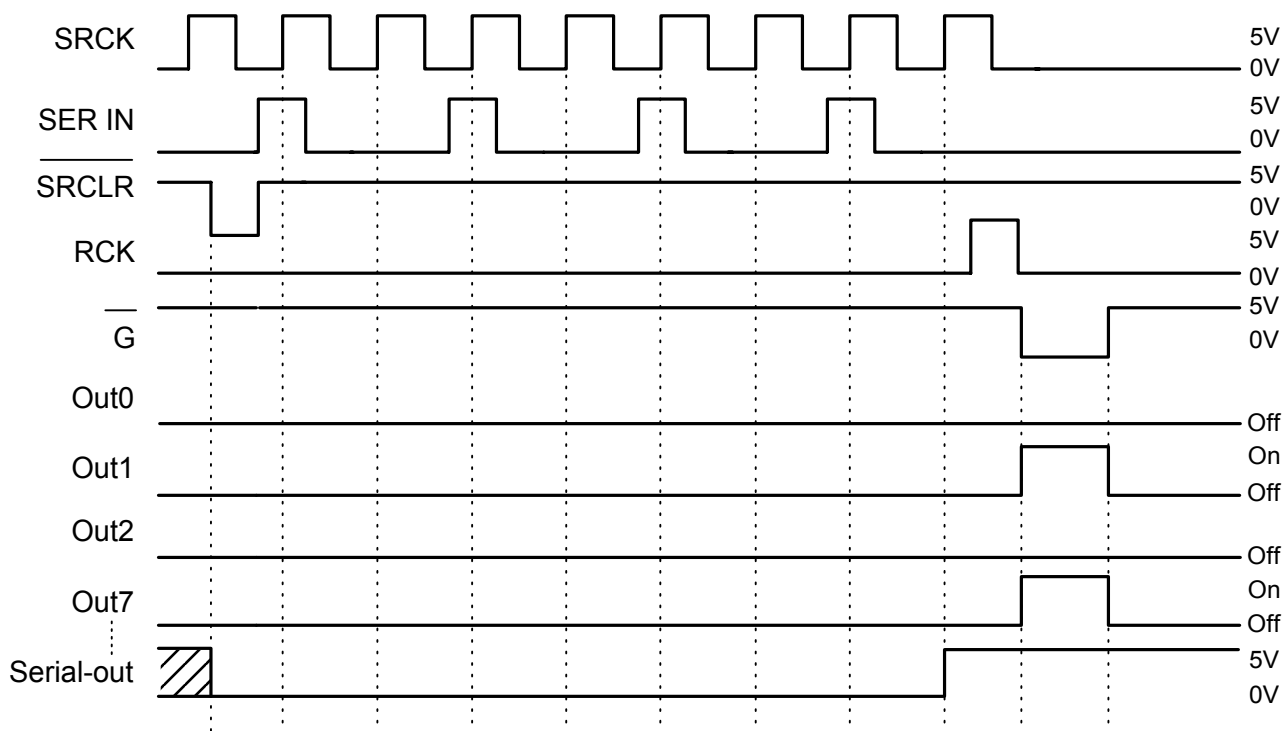



TRUTH TABLE

SERIN	SRCK	SRCLR	Shift-register	SEROUT	RCK	Storage-register	\overline{G}	OUT0 OUT1...OUT7
H	\uparrow	H	H R ₀ R ₁ ... R ₅ R ₆	R ₆				
L	\uparrow	H	L R ₀ R ₁ ... R ₅ R ₆	R ₆				
X	\downarrow	H	R ₀ R ₁ R ₂ ... R ₆ R ₇	R ₇				
X	X	L	L L L ... L L	L				
			X X X ... X X	X	—	R0 R1 R2 ...R6 R7		
			P ₀ P ₁ P ₂ ... P ₆ P ₇	P ₇	\uparrow	P0 P1 P2 ... P6 P7	L	P0 P1 ... P7
						X X X ... X X	H	H H ... H

P : Present state. R : Previous state.

MAXIMUM RATINGS (Ta = 25°C unless otherwise noted)

Characteristic	Symbol	Rating
Logic Supply Voltage	VCC	7 V
Logic Input Voltage	VIN	- 0.3 ~ 7V
Output Current	IOUT	100 mA
Output Voltage	VOUT	30 V
Operating Temperature	Topr	-40 ~ 125 °C
Storage Temperature	Tstg	-55 ~ 150 °C



RECOMMENDED OPERATING CONDITIONS

Characteristic	Symbol	Condition	Min.	Typ.	Max.	Unit
Supply Voltage	VCC	—	4.5	5.0	5.5	V
Output Voltage	VOUT	OUTn	—	—	30	V
Output Current	IO	OUTn	—	—	100	mA
Input Voltage	VIH	—	0.85Vcc	—	—	V
	VIL	—	—	—	0.15Vcc	V
Set-up Time for SER IN	tsetup	—	20	—	—	ns
Hold Time for SER IN	t _{hold}	—	20	—	—	ns
Pulse duration for SER IN	tw	—	40	—	—	ns
Operating Temperature	Topr	—	-40	—	85	°C



ELECTRICAL CHARACTERISTICS (V_{DD} = 5.0V, T_a = 25°C unless otherwise noted)

Characteristic	Symbol	Condition	Min.	Typ.	Max.	Unit
Output breakdownvoltage	V(BR)DSX	I ₀ =1mA	30	—	—	V
Off-state leakage current	IDSX	V ₀ =24V, V _{cc} = 5.5V	—	0.5	5	μA
		V ₀ =24V, V _{cc} =5.5V, T _c =125 °C	—	10	30	
		V ₀ =12V, V _{cc} = 5.5V	—	0.1	1	
		V ₀ =12V, V _{cc} =5.5V, T _c =125 °C	—	1	3	
Static drain-source on-state resistance	RDS(ON)	I ₀ = 100mA, V _{cc} = 4.5V	—	5	—	Ω
Nominal Current	I _N	V _{DS(on)} =0.5V, T _a =85 °C	—	90	—	mA
Logic input current	I _{IH}	V _I = V _{cc} =5.5V	—	—	1	μA
	I _{IL}	V _I = 0, V _{cc} =5.5V	—	—	-1	μA
Logic Supply Current	I _{CC}	V _{CC} =5.5V	—	20	100	μA
SER OUT output voltage	V _{OH}	I _{OH} = -20μA, V _{cc} = 4.5V	4.4	4.49	—	V
		I _{OH} = -4mA, V _{cc} = 4.5V	4.0	4.2	—	V
	V _{OL}	I _{OL} =20μA, V _{cc} = 4.5V	—	0.005	0.1	V
		I _{OL} = 4mA, V _{cc} = 4.5V	—	0.3	0.5	V
Propagation delay (G-OUTn)	t _{PLH}	I ₀ = 100mA, CL=30PF	—	150	—	ns
	t _{PLH}	I ₀ = 100mA, CL=30PF	—	90	—	ns
Output rise time	t _r	I ₀ = 100mA, CL=30PF	—	200	—	ns
Output fall time	t _f	I ₀ = 100mA, CL=30PF	—	200	—	ns



TIMING WAVEFORM

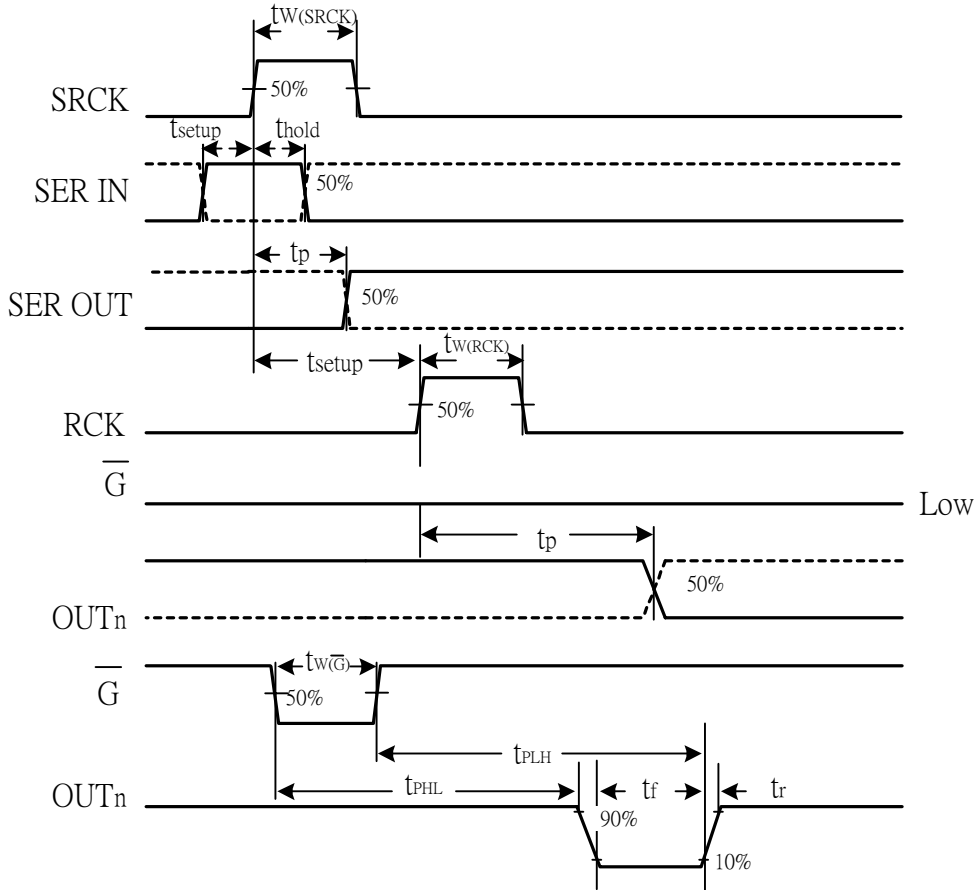



PACKAGE OUTLIN

20 PINS DIP

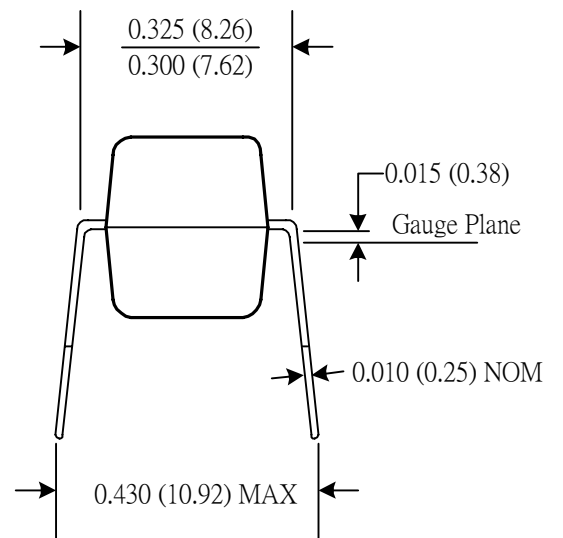
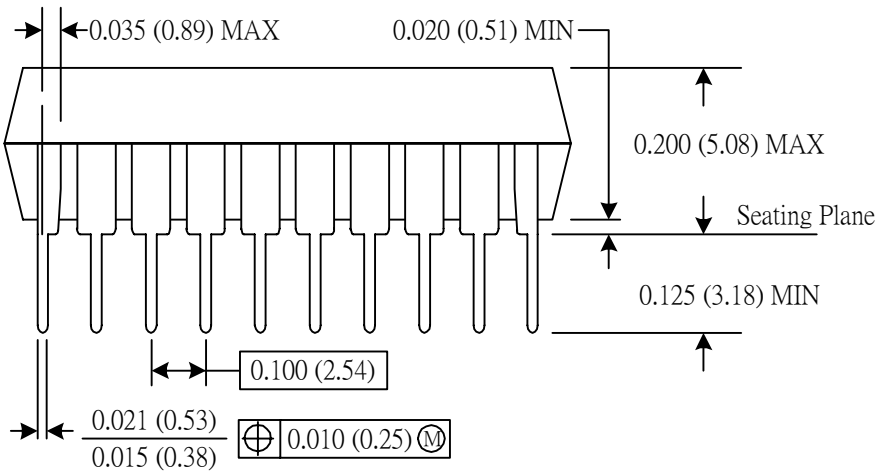
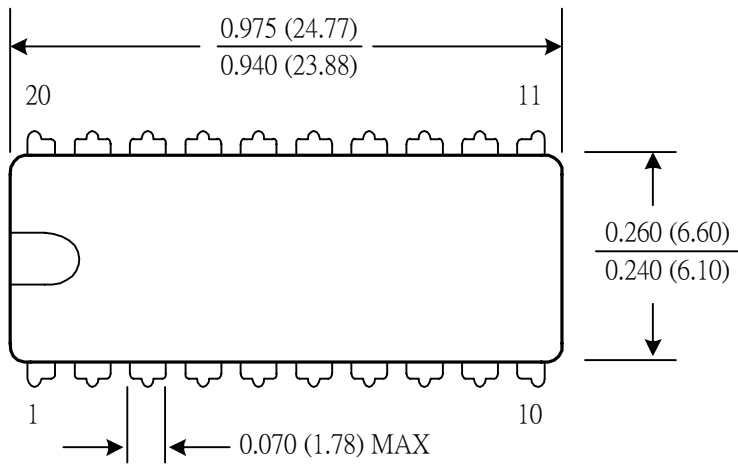

UNIT : inches (millimeters)



PACKAGE OUTLIN

20 PINS SOP

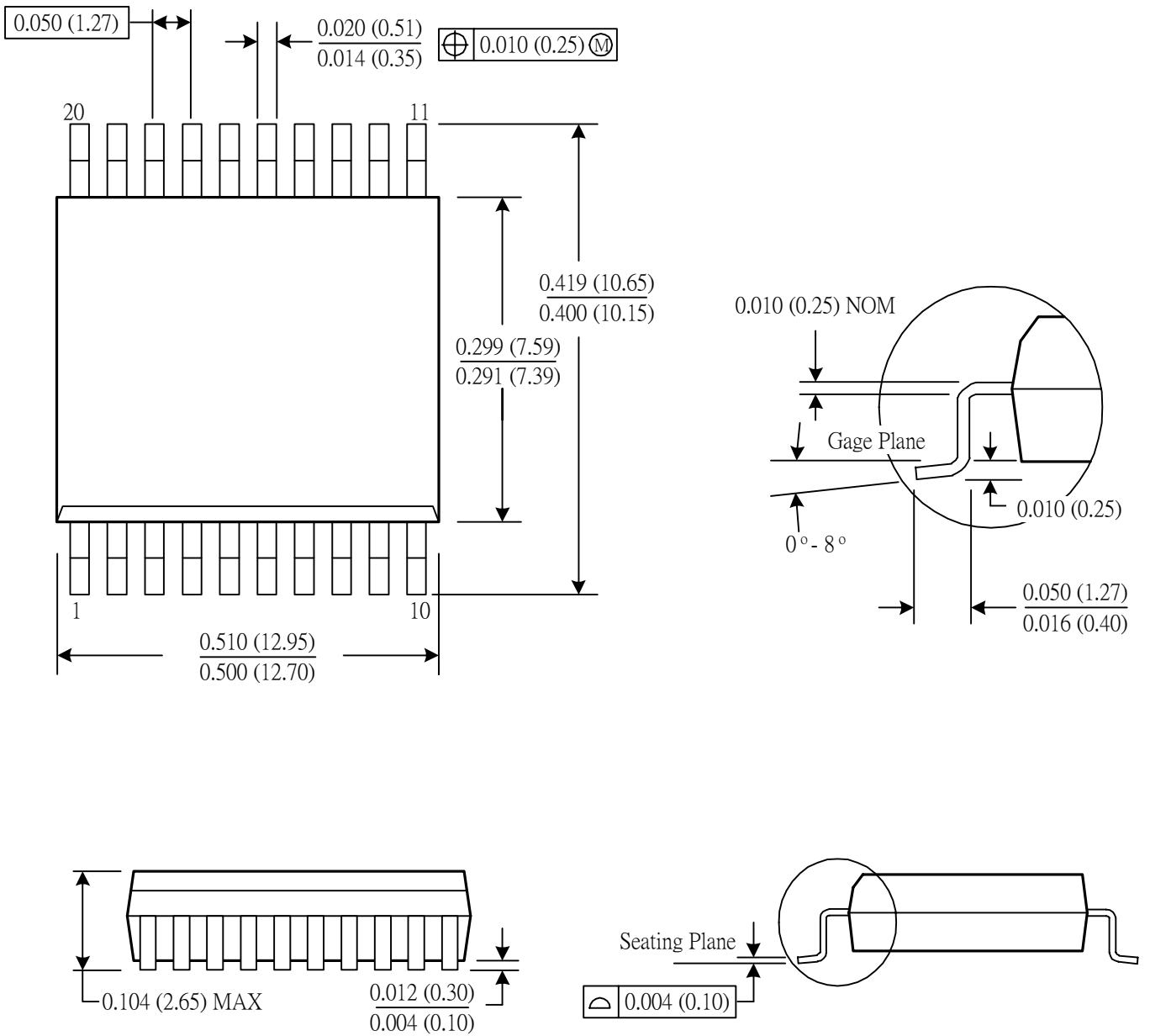

UNIT : inches (millimeters)